

National Grid UK Electricity Transmission plc

Uncontrolled when printed

NATIONAL SAFETY INSTRUCTION and Guidance

NSI 26 RAILWAY CONNECTION CIRCUITS

Copyright National Grid plc 2017 ©, all rights reserved. No part of this publication may be reproduced, stored in a retrieval system, or transmitted in any form or by any means electronic, mechanical, photocopying, recording or otherwise, without the written permission of National Grid obtained from the issuing location.

The contents of National Grid documents are based on the needs of National Grid and the conditions under which it operates. It shall not therefore be assumed that the contents stated therein necessarily meet the particular circumstances and requirements of other organisations. The principles set out in this document are for information only and therefore National Grid is not liable to any third party for any loss or damage resulting from reliance on the contents. It is the responsibility of such external organisations to check that the document is the latest version and is appropriate for their purposes.

DOCUMENT HISTORY

Issue	Date	Summary of Changes / Reason	Author(s)	Approved By (Title)
1	Oct 2014	New document created from G3 procedure NS-G3-05.	NATIONAL SAFETY INSTRUCTION Working Group	Mike Dean ETAM Operations Manager North
2	June 2015	Added: Barking 132kV – Barking 25kV Contractor appointment matrix	NATIONAL SAFETY INSTRUCTION Working Group	Matt Staley ETAM Operations Manager North
3	July 2016	Added Configurations: Kensal Green 400kV – Kensal Green 25kV Didcot 400kV - Foxhall Junction 25kV Melksham 400kV – Thingley Junction 25kV. Minor changes to area 2B link CL1 reference	NATIONAL SAFETY INSTRUCTION Working Group	Matt Staley ETAM Operations Manager North
4	July 2017	Added Configurations: Pudding Mill Lane 400kV – Pudding Mill Lane 25kV Ryhall 400kV - Essendine 25kV	NATIONAL SAFETY INSTRUCTION Working Group	Matt Staley ETAM Operations Manager North

KEY CHANGES

Section	Amendments
Appendix C	Modification to Configuration M & Configurations N & P

RAILWAY CONNECTION CIRCUITS

CONTENTS

	Page
1 Purpose and Scope	1
2 Definitions	2
3 Dangers	4
4 Control of Alternative Current Return (ACR) current	5
5 Switching and establishing ACR safety precautions	11
6 Management of Links	14
7 Inadvertent ACR current parallel paths	17
8 Working on Cables	18
9 Testing	18
Appendix A Example of a completed Safety Document .	19
Appendix B Switching Instructions for Railway Connection Circuits	20
Appendix C Configurations Index	24
Appendix D Authorisation Matrix for Contractors Personnel	183

1 Purpose and Scope

To apply the principles established by the Safety Rules and provide guidance on National Safety Instruction 26 when applying the principles to achieve safety from *Alternative Conductor Return ACR Current(s)* for **Personnel**, working on *Railway Connection Circuit(s)*.

National Safety Instruction 26 gives direction on:

- The avoidance of *ACR Current(s)* and earth fault current(s) which could potentially harm **Personnel** when locally switching or single circuit working on **Equipment** associated with multiple railway connection circuits
- Establishing safety from *ACR Current(s)* when working on cables associated with *Railway Connection Circuit(s)*.
- The procedure for removal and replacement of the neutral link and the limitation of alternative *ACR Current(s)* whilst operating the neutral link

Management of the cross boundary interface with the *Railway Connection Circuit(s)* operator shall be achieved in accordance with the Grid Code OC8; a site specific G38 procedure and UK/BP/SE/301 Managing Safety Interfaces.

If all *Railway Connection Circuit(s)* at a site supplying a common railway supply point are out of service and a safe system of work established to ensure that this situation will continue throughout the period of the works, then there is no **Danger** of *ACR Current(s)*.

When undertaking safety switching and **Safety Document** procedures to establish *ACR* precautions on *Railway Connection Circuit(s)*, this shall be undertaken by a **Senior Authorised Person** and **Control Person (Safety)** appointed to this National Safety Instruction.

The normal operating voltage of a *Railway Connection Circuit(s) Neutral Conductor* is nominally zero volts, hence under the National Grid UK Electricity Transmission safety rules this conductor is not classified as **HV** although it does form part of National Grid's **HV System**. Technical report TR(E) 483 'Railway 25kV Neutral Conductor: Isolation and Earthing during Maintenance' identifies that in order to comply with the National Grid UK Electricity Transmission Safety Rules, The Electricity at Work Regulations 1989 and to protect **Personnel**; **Point(s) of Isolation** shall be established on the neutral conductor.

At some sites the design of **Equipment** includes the *Auxiliary Pole (A Pole)*, *Catenary Pole (C Pole)* and *Neutral Conductor* on the same structure. For this type of **Equipment** when establishing **Point(s) of Isolation / Primary Earth** on the *Auxiliary Pole (A Pole)* and *Catenary Pole (C Pole)*, **Point(s) of Isolation / Primary Earth** are also created on the *Neutral Conductor*.

The layout of this guidance note reflects that of legislative codes of practice, where the rule (or mandatory obligation) is identified by a green panel on the left-hand side. The guidance follows after the rule and is identified by a blue panel.

Within National Grid the guidance notes hold equivalent status of an Approved Code of Practice (ACOP) in law. If not followed, you will be required to demonstrate that your safe system of work is of an equal or higher standard.

2 Definitions

Terms printed in bold type are as defined in the Safety Rules.

Title	Definition
<i>Alternative Conductor Return (ACR) current</i>	Return current carried by a National Grid conductor or cable sheath, which is not the <i>Neutral Conductor</i> of the supplying transformer
<i>Auto Transformer (AT) Mode</i>	A connection arrangement where both the A pole and the C pole busbars are energised and capable of providing a supply to the rail operator
<i>Booster Transformer (BT) Mode</i>	A connection arrangement where only the <i>C Pole</i> busbar is energised and providing a supply to the rail operator. The <i>A pole</i> , if present, will be disconnected from the transformer and connected to earth by a permanent earth connection, usually within the 25 kV substation
<i>Configuration</i>	A connection arrangement that can apply to more than one substation.
<i>Earth Bond(s)</i>	A type registered bridging connection used for the purpose of providing earth continuity on earth connections. They are clear in colour and are fully fault rated when applied in appropriate numbers. Type A - An <i>Earth Bond</i> consisting of; two CE 20 earth end clamps supplied with one 150 mm ² Aluflex lead (clear sheath), ends crimped with ESI/T1 compression terminations.
<i>Earth Continuity Conductor (ECC)</i>	An earth bond that extends from the substation earth mat to bond cable link boxes along the cable route
<i>Earthing Restriction Zone</i>	A zone where the earthing of any conductors or Equipment has been restricted for the prevention of <i>ACR Current(s)</i>
<i>Intermediate Neutral Earth (INE)</i>	A permanent earth applied to the <i>Neutral Conductor</i> at an intermediate point between the transformer and the railway neutral earthing points
<i>Making Equipment Available</i>	Removing the safety precautions taken to create a <i>Point of Immobilisation</i>
<i>Neutral Conductor</i>	The designated return conductor for the Catenary and Auxiliary Poles i.e. C-N & A-N connections
<i>Pole</i>	One of, <i>Auxiliary Pole (A Pole)</i> or, <i>Catenary Pole (C Pole)</i>
<i>Auxiliary Pole (A Pole)</i>	A 25 kV to neutral supply i.e. A-N connection, with a 180 degree phase angle separation from the <i>Catenary Pole</i> of the same transformer. This pole does not exist on a <i>BT Mode</i>
<i>Catenary Pole (C Pole)</i>	A 25 kV to neutral supply (C-N connection)
<i>Point of Immobilisation</i>	The point at which Equipment has been Locked open to establish safety precautions to prevent <i>ACR Current(s)</i> . A <i>Point of Immobilisation</i> notice shall be attached.
<i>Railway Connection Circuit</i>	A National Grid circuit identified in Appendix C providing a connection to a rail operators system
<i>Radial Earth</i>	An earth bond that extends from a substation earth mat to manage the characteristic of the rise of earth potential contours.

<i>Temporary Earth Bond(s)</i>	<p>A type registered bridging connection used as an initial connection to eliminate Danger on any <i>Inadequate System</i>.</p> <p>Leads are coloured blue and Consists of two 50mm² Aluflex leads (blue sheathed), ends crimped and affixed with a CE20/2 earth end clamp and a CE57 earth end clamp.</p>
<i>Temporary Earth Bond Pole</i>	<p>A type registered device for the application of <i>Temporary Earth Bond(s)</i>.</p>

3 Dangers

The main **Dangers to Personnel** from operating **HV Equipment** at *Railway Connection Circuit(s)* are electric shock, burns and effects on eyes arising from the inadvertent connection of separate earthing systems due to:

- The application / removal of an **Earthing Device** to **Equipment** capable of carrying *ACR current*, earth fault current and induced current.
- The connection or disconnection of **Equipment** capable of carrying *ACR current* or earth fault current.
- The opening or closing of a neutral link, *Intermediate Neutral Earth*, cable sheath or earth capable of *ACR current*.
- The inadvertent connection or disconnection of earthing systems.

NSI 26
4.1 to 4.5

4 Control of ACR Current

4.1 If all *Railway Connection Circuits* at the site are out of service, and a safe system of work established to ensure that this situation will continue throughout the period of the works, then there is no **Danger** of *ACR Current(s)*.

4.2 If Section 4.1 can not be complied with, the method of eliminating *ACR Current(s)* and earth fault current(s) flowing through the point of work is to eliminate any parallel path along which *ACR* or earth fault current(s) may flow.

This is achieved by the immobilisation of an open disconnector, earth switch or neutral conductor link and may require any combination of the following actions:

- The setting up of an *Earthing Restriction Zone*.
- The safe removal of cable sheath bonding links.
- The safe removal of a permanent busbar earth connection.
- The safe removal of *Intermediate Neutral Earth (INE)*.

Specific *configurations* of National Grid *Railway Connection Circuits* to which this National Safety Instruction applies shall be produced.

The rail operator's equipment shown in any *configuration* shall be considered as indicative only and may vary from that indicated.

Where *ACR Current(s)* precautions are required across the control boundary between National Grid and a rail operator the safe working arrangements shall be identified in a site specific G38 procedure.

4.3 Safe working arrangements shall be identified by the **Senior Authorised Person** prior to the commencement of any work on a *Railway Connection Circuit*

4.4 **Point(s) of Isolation** shall be established on neutral conductors; however **Primary Earths** are not required to be applied to the neutral conductors between the **Point(s) of Isolation** and the point of work.

An earthing device shall be applied to the neutral conductor between the **Point(s) of Isolation** and the point of work.
local to point of work

4.5 If the *BT mode* earth is to be removed a **Permit for Work** shall be issued.

Guidance
NSI 26
4.1 to 4.2

4 Control of ACR Current

4.1 To avoid any possibility of *ACR current(s)* at the point of work and to ensure a safe system of work is maintained, **Point(s) of Isolation** on each adjacent *Railway Connection Circuit* shall be established. If the **Point(s) of Isolation** are located on the LV side of the connection transformer then, to avoid danger from fault return current through the point of work, the **Point(s) of Isolation** shall be located on the same earth mat as the connection transformer. Figure 4.1A illustrates the required position of the **Point(s) of Isolation**.

The **Point(s) of Isolation** on each adjacent *Railway Connection Circuit* shall be recorded in Section 2 of the **Safety Document**.

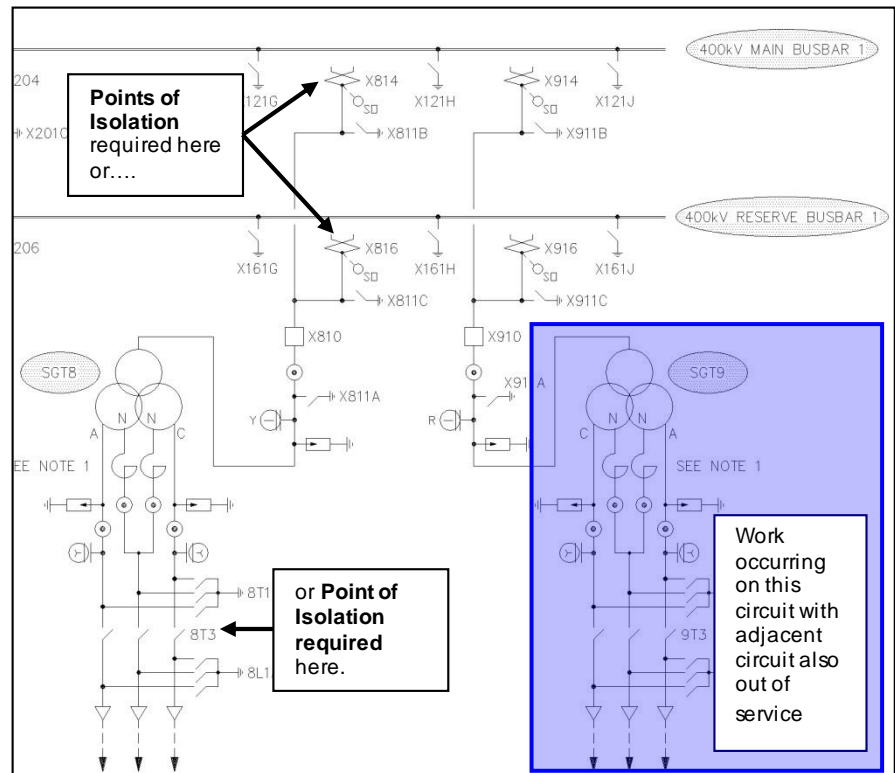

Note: 8T3 is on the same earth mat as SGT8

Figure 4.1A – **Point(s) of Isolation** on each adjacent *Railway Connection Circuit*

4.2 For new National Grid *Railway Connection Circuits* it is preferable that one of the existing layout *configurations* is chosen at the design stage. If the new *Railway Connection Circuit* does not match one of the existing arrangements the commissioning panel chairman shall be responsible for producing a set of *Specific configurations*, work areas and precautions to be taken.

For a new *Railway Connection Circuit* that matches an existing *configuration* the name of the **Location** shall be added to the table in Appendix C.

The new *configuration* shall be submitted to Safety Rules Assurance Team for re-issue of the NSI a minimum of 6 months before commissioning. **Changes to existing configurations shall follow the same process.**

Guidance
NSI 26
4.3

4.3 Appendix C identifies the safe working areas for each *configuration* and includes the pole and neutral line diagram for one *Railway Connection Circuit* only. An example is given below in Figure 4.3A

The **Equipment** arrangement for permanent *BT Mode* operation is shown in blue. This includes an additional fixed earth on the *A pole*, also annotated in blue.

The areas to be controlled by the safe working arrangements are numbered and shown boxed in yellow with a blue border.

Earth mats are shown in green and numbered; any interconnection between each earth mat is shown.

Precaution required to be taken to avoid *ACR current* are identified as Blue circles with a yellow background and are detailed in the attached schedule.

The *Earthing Restriction Zone* is identified in pink shading.

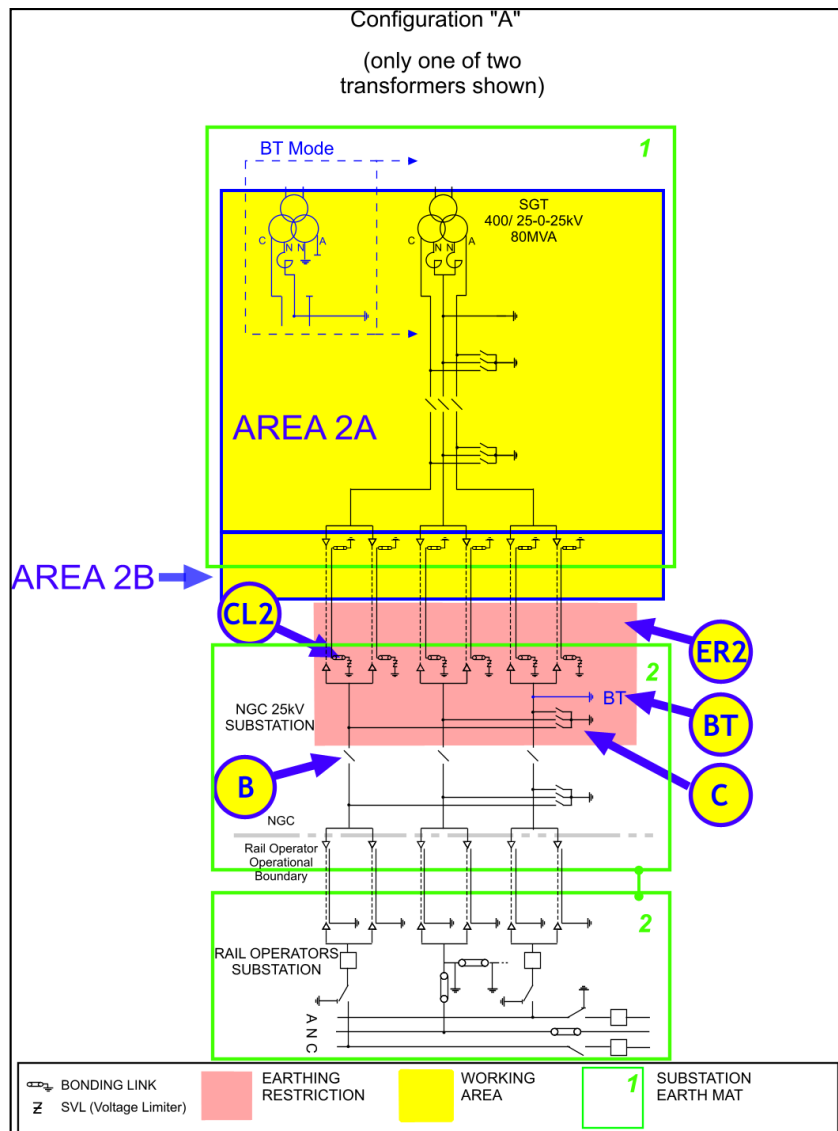

Figure 4.3A – Example of safe working arrangement diagrams

Guidance
NSI 26
4.3 cont

For work on a cable the **Senior Authorised Person** shall make a decision as to which work area applies.

If there is any possibility of contact with a cable sheath bonded to a separately earthed site then the work area chosen shall be the one that includes the cable sheath connections. Figure 4.3B identifies the boundary of the work areas and the decision as to which work area to be used.

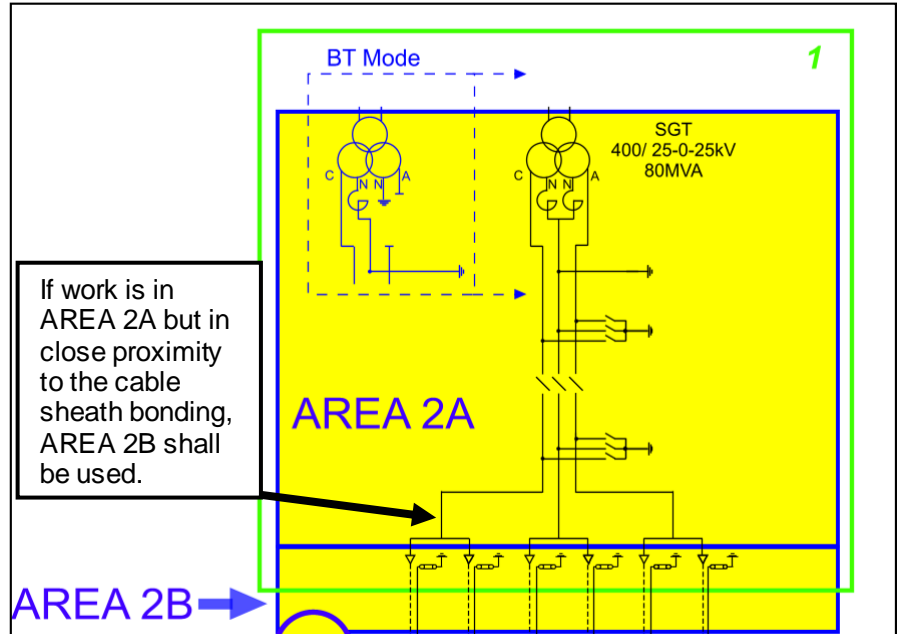

Figure 4.3B example of decision of work area when working in proximity to cable sheath bonding

Where works on a cable system are near to the boundary of a substation earth mat, or an extension to this such as an *ECC*, then a decision on work area shall be based on:

- a) Where there is a possibility of bridging between the point of work and the substation earth mat the arrangement for working on the cable sealing ends shall be used, in the example above this would be AREA 2B. This includes where the substation earth mat is extended via the radial earth or *ECC*.
- b) Where it is not practicable to run a remote earth connection to the point of work from the nearest earth mat and it is not possible for anything to bridge the gap, the works shall be deemed to be in area associated with the cable (AREA 3).

Note: for Area 2B and 3 refer to the substation specific *configuration* diagrams in APPENDIX C

Work shall only occur in one AREA at a time to avoid any conflict between *ACR current* precautions. However in the above scenario working in AREA 2B by default also includes work in AREA 2A.

Guidance
NSI 26
4.4

4.4 The normal operating voltage of a *Railway Connection Circuit(s) Neutral Conductor* is nominally zero volts, hence under the National Grid UK Electricity Transmission Safety Rules this conductor is not classified as **HV** although it does form part of National Grid's **HV System**.

Technical report TR(E) 483 'Railway 25kV Neutral Conductor: Isolation and Earthing during Maintenance' identifies, that in order to comply with the National Grid UK Electricity Transmission Safety Rules, The Electricity at Work Regulations 1989 and to protect **Personnel**; **Point(s) of Isolation** shall be established on the neutral conductor. In addition the report identifies there is no additional protection afforded by the application of **Primary Earths** to the neutral conductor. In some cases the application of **Primary Earths**, will introduce a hazard into the work area arising from the risk of rise of earth potential following a fault on the railway system. However the report identifies the neutral conductor shall be earthed locally by the application of an **Earthing Device**. A **Drain Earth** is suitable for this application.

A **Point(s) of Isolation** established on the neutral may also be a *Point of Immobilisation* under this procedure.

If the **Point(s) of Isolation** on the neutral also establishes **Point(s) of Isolation** on the phase conductors the **Point(s) of Isolation** may not satisfy the requirement for the phase conductors as **Primary Earths** can not be applied between the **Point(s) of Isolation** and the point of work. In this case the **Point(s) of Isolation** shall be identified as for the neutral conductor only by identifying the **Point(s) of Isolation** on the document as for the neutral only.

In Figure 4.4 below, **Point(s) of Isolation** for the phase conductors can be established on the disconnectors in the rail operator substation (disconnector D) and primary earthing can be achieved by the application of the 25kV site earth switch (earth switch E).

As there is no requirement on the neutral conductor to apply **Primary Earths** between the **Point(s) of Isolation** and the point of work, disconnector B can be used as a **Point(s) of Isolation** in preference to removing the neutral link in the rail operator substation. However, disconnector B could not be used as **Point(s) of Isolation** for the phase conductors as **Primary Earths** would be required to be applied in the earthing restriction zone ER2.

The **Point of Isolation** for the neutral, disconnector B, shall be identified on the safety document as [disconnector number] (Neutral Only) e.g. in section 2 of the safety document:

"1L3 (Neutral Only)"

In this arrangement disconnector B is also a point of immobilisation.

Guidance
NSI 26
4.4 cont.

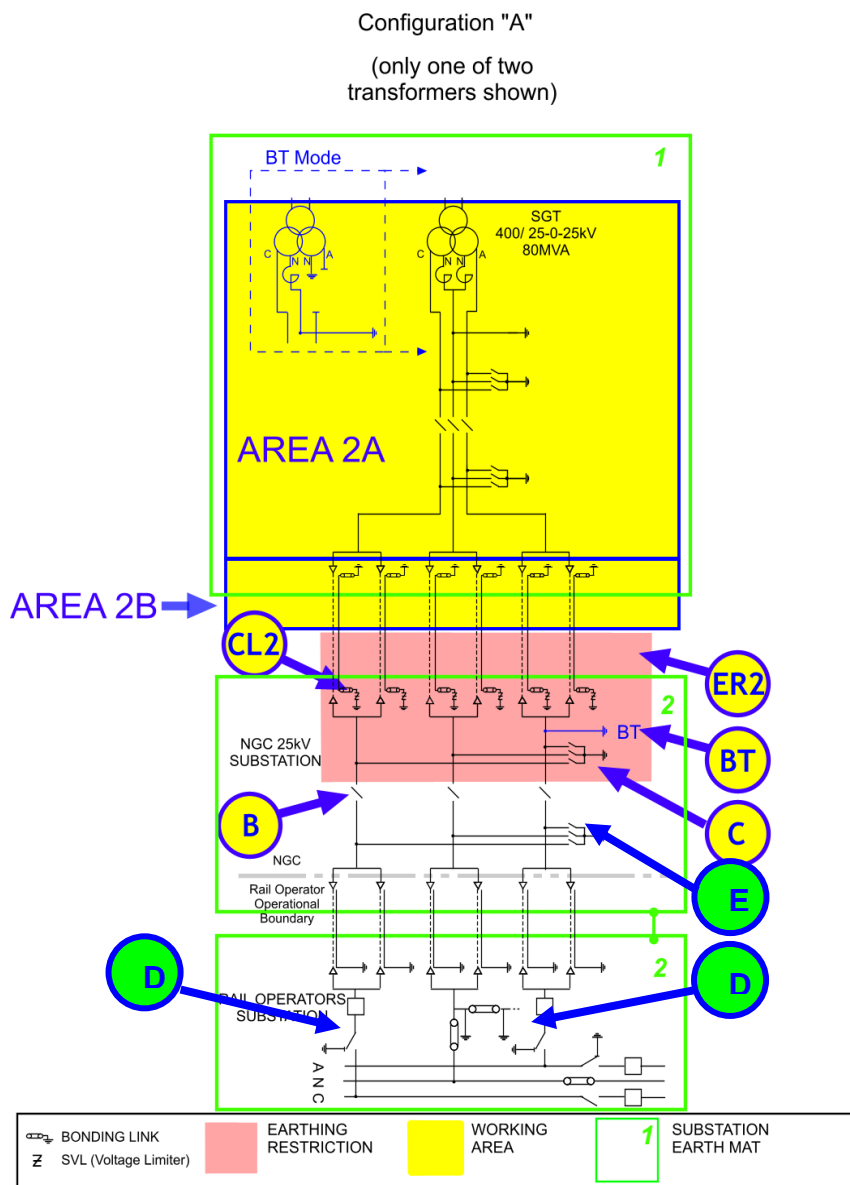

Figure 4.4 An example of **Point(s) of Isolation** on the neutral conductor only.

NSI 26
5.1 to 5.6

5 Switching and Establishing ACR Safety Precautions

- 5.1 A **Senior Authorised Person** and **Control Person (Safety)** shall ensure safety precautions are established.
- 5.2 All *ACR* safety precautions established or to be established as a requirement of this National Safety Instruction shall be listed under the “Further Precautions” section of the safety document.
- 5.3 In order that safety precautions are not compromised, no work shall be carried out on any **Equipment** which has been made a *Point of Immobilisation*, or that is in an *Earthing Restricted Zone*.
- The use of a disconnector, as a *Point of Immobilisation* does not preclude that disconnector from being used as a **Point of Isolation**.
- The use of a disconnector, as a **Point of Isolation** does not preclude that disconnector from being used as a *Point of Immobilisation*.
- 5.4 In order to establish *ACR* safety precautions the **Control Person (Safety)** shall prepare and issue a switching instruction to the **Senior Authorised Person**.
- 5.5 Other than for the purpose of testing, the **Senior Authorised Person** shall ensure that no metallic connection can be made between separated earth mats via the circuit being worked on.
- 5.6 When shorting cable sheath bonding links at a position protected by cable sheath voltage limiters (SVLs), a metallic connection between the earth mats shall be avoided by opening the solidly earthed cable sheath bonding links associated with the cable section first.

Guidance
NSI 26
5.1 to 5.2

5 Switching and establishing ACR safety precautions

- 5.1 To enable the **Control Person (Safety)** function to be adequately managed a Job Information Form (JIF) or a draft **Permit for Work** shall be forwarded to the .box.noc.planning email address at least 72 hours before safety precautions / safety documents are required.

This notification will detail all safety precautions, a description of the work to be undertaken and the work area, as defined within this National Safety Instruction, applicable to the requested safety document.

For an emergency situation the 72 hour notice can be reduced with the agreement of the **Senior Authorised Person** and the Transmission Network Control Centre (TNCC).

- 5.2 The "Further Precautions" section of the **Safety Document** shall detail:

1. The *configuration* letter and area number to which the ACR current precautions have been established.
2. The nomenclature of the **Equipment** which the ACR current precautions have been applied.

Appendix A gives an example of a completed **Safety Document**.

In order to comply with the above requirements and the safety rules, the following process has been identified for the removal of any cable sheath bonding links that can be removed without the need for all the *Railway Connection Circuits* to be out of service:

- The ACR precautions required to be established at a cable sheath bonding link box will be referenced in the further precautions section of the **Safety Document** as links to be removed prior to the work commences.

The Further precautions section of the **Safety Document** shall be completed with the following statement:

"Ensure cable Sheath Bonding Links XYZ are removed before work commences."

Where, XYZ is the reference to the cable sheath link in the appropriate *configuration*.



- The **Senior Authorised Person** will initially receive the **Safety Document** and without delay shall establish the ACR safety precautions on the cable sheath bonding links using the NSI 5 or NSI 24 type registered equipment as appropriate.

Guidance
NSI 26
5.2 cont. to 5.6

- Once all the ACR precautions are established, the **Safety Document** can then be transferred to the **Competent Person** undertaking the work. The **Senior Authorised Person** shall complete a status of transfer form stating in section 2 that the “Cable Sheath Bonding Links XYZ have been removed”. Any additional safety keys shall be retained with the safety document and identified on the status of transfer form.
- Before the cancellation of the last **Safety Document** issued quoting cable Sheath Bonding Links established as *ACR* precautions, the **Senior Authorised Person** shall ensure the cable Sheath Bonding Links are replaced to the operational state.

WARNING, some *arrangements* where the cable sheath solidly bonds two remote earth mats requires all the *Railway Connection Circuits* to be out of service at that **Location** before the removal of the cable sheath links. Follow any warnings identified in the appropriate *configuration* and precautions to be taken table.

5.3 When **Equipment** is to be established as a *Point of Immobilisation* the appropriate notice shall be attached to the **Equipment**.

DO NOT CLOSE NOTICE	<p>The National Grid Company</p>  <p>ALTERNATIVE CONDUCTOR RETURN CURRENT PRECAUTION</p> <p>DO NOT CLOSE</p>
DO NOT EARTH CONDUCTORS NOTICE	<p>The National Grid Company</p>  <p>ALTERNATIVE CONDUCTOR RETURN CURRENT PRECAUTION</p> <p>DO NOT EARTH CONDUCTORS</p>

5.4 *ACR* Safety Precautions Switching Instructions shall be specified in Appendix B

5.6 *ACR* Safety Precautions on Cable Sheath Bonding Links.

An SVL shall not be considered as a suitable disconnection. The links to the SVL shall be removed following the removal of the solidly connected cable sheath earth links at the remote end first. *Point of Immobilisation* shall be established at the points where links have been removed. This requirement also applies to the rail operators cables.

NSI 26
6.1 to 6.4

6. Management of Links

6.1 In order to prevent **Danger** from *ACR current* and **Impressed Voltage** conditions:

- Before a neutral link is removed a *Temporary Earth Bond* shall be applied either side of the neutral link.
- Before an *INE link* is removed a *Temporary Earth Bond* shall be applied to the *Neutral Conductor* side.
- Before a cable sheath bonding link(s) is removed, a *Temporary Earth Bond* shall be applied to the cable sheath bonding link(s) by the **Senior Authorised Person**

Removal of cable sheath bonding link(s) outside the substation shall be carried out in accordance with NSI 5 "Cable Systems".

Where the 25-0-25kV transformer winding is **Earthed** on the railway operator's earth mat and this is separate to the National Grid earth mat, the railway operator shall remove the earth from the *Neutral Conductor* before the National Grid neutral link is removed.

6.2 When carrying out work that is not removing links in the substation cable sheath bonding link box, the *Temporary Earth Bond* shall be replaced with the correct number of Type A *Earth Bond(s)* attached across the link to earth by the **Senior Authorised Person**.

6.3 When restoring the neutral link, *INE* or cable sheath bonding link(s) the reverse of this procedure shall be employed.

6.4 When shorting across cable sheath bonding links at a position protected by cable sheath voltage limiters (SVLs), the cable bonding links at the solidly bonded position shall be removed prior to removing the links, or SVLs, at the SVL link box position.

Guidance
NSI 26
6.1

6. Management of Links

- 6.1 The *Temporary Earth Bond* has been tested and assessed to meet the calculated continuous and fault rating of the neutral conductor as identified in Technical report TR(E) 483 'Railway 25kV Neutral Conductor: Isolation and Earthing during Maintenance'

A *Temporary Earth Bond Pole* comes in two sections, each 0.6 metre in length, the top section fitted with an OL1 operating socket. It has blue banding on each section.

The top section pole incorporates a single flexible shed that prevents the operator from accidentally touching the earth end clamp during an application or removal action.

The arrangements of the *Temporary Earth Bond* and *Temporary Earth Bond Pole* are shown in figure 6.1A



Figure 6.1A - *Temporary Earth Bond* and *Temporary Earth Bond Pole*

The first connection of the *Temporary Earth Bond* shall be made by hand by applying the earth end clamp (CE20/2) to the earth side of the cable sheath bonding link. Figure 6.1B refers.



Figure 6.1B - CE20/2 clamp

Guidance
NSI 26
6.1 cont to 6.2

The second connection to make the bridge complete will be done by applying the CE57 clamp of the *Temporary Earth Bond* using the supplied *Temporary Earth Bond Pole* onto the sheath side of the cable sheath bonding link. Figure 6.1C refers.



Figure 6.1C - *Temporary Earth Bond*

Prior to the removal or replacement of the National Grid neutral link, and provided the National Grid neutral link is positioned within the same earthing mat as the rail operator, there is no requirement isolate the railway operator's neutral links prior to issuing the switching instruction to remove the National Grid neutral link. Where the National Grid earth mat and the rail operator's earth mat are not connected, the railway operator's neutral earth connection and neutral link must be removed and maintained prior to the removal the National Grid neutral link.

- 6.2 When carrying out work that is not removing links in the substation cable sheath bonding link box a *Temporary Earth Bond* shall be applied, followed by the appropriate numbers of Type A *Earth Bond(s)* as soon as is reasonably practical by the **Senior Authorised Person**. The number of Type A *Earth Bond(s)* to be applied shall achieve the fault rating / circulating current capacity as defined within NSI 2 - "Earthing High Voltage Equipment".

After the appropriate number of Type A *Earth Bond(s)* are applied the *Temporary Earth Bond* can be removed.

NSI 26
7.1

7. Inadvertent ACR Current Parallel Paths

- 7.1 When a National Grid transformer winding is locally earthed and an inadvertent connection between separate earth systems is made, an ACR and earth fault current parallel path will be established and ACR current(s) will flow.

If a parallel path has been established the **Senior Authorised Person** shall check that the in-service *Railway Connection Circuit Neutral Conductor* has not been compromised.

If the in service *Railway Connection Circuit Neutral Conductor* has been compromised then the associated in service circuit *Railway Connection Circuit* shall be removed from service before removing the parallel path. Under these circumstances load current shall not be broken by the opening of a disconnector. This applies whether or not the disconnector has been fitted with bus transfer duty contacts.

If the in service *Railway Connection Circuit Neutral Conductor* has not been compromised the **Senior Authorised Person** shall liaise with the appropriate **Control Person** to either:

- Break the parallel path using a disconnector with a suitable bus transfer duty rating.
- Or open a standard disconnector once all associated railway connection circuits have been switched out of service.

Guidance
NSI 26
7.1

7. Inadvertent ACR Current Parallel Paths

- 7.1 When a National Grid transformer winding at a **Location** is remotely Earthed via the rail operator's earth mat, and this is separated from the National Grid earth mat, then the circuit configuration is such that ACR Current will not flow. However the segregation of earth mats is required to manage rise of earth potential issues and any inadvertent connection shall be removed as soon as possible.

An example of an inadvertent connection could be by the application of **Earthing Device(s)** so they connect two separate earth mats together.

The integrity of the in service *Railway Connection Circuit Neutral Conductor* can be checked by establishing that a measurable current is flowing in the in-service neutral by the use of a clip on ammeter around the neutral conductor or indirectly via the CT or relay of the in-service neutral.

NSI 26
8.1

8. Working on Cables

8.1 When working on cables consideration shall be given both to the effects of impressed voltages and of *ACR Current(s)*. This National Safety Instruction does not remove the requirements from NSI 5 for working on cables.

Guidance
NSI 26
8.1

8. Working on Cables

8.1 When it is necessary to apply earths to cable sheaths or cable conductors then, where reasonably practicable, this shall only be performed at one location at any one time (e.g. at a joint bay).

If it is not reasonably practicable to meet this requirement then concurrent working on the same cable at a multiple of earthed locations may only be performed after a work specific risk assessment has been produced.

NSI 26
9.1

9. Testing

9.1 Where **HV** Testing is required under National Safety Instruction 9 and a **Sanction for Work** has been issued to a **Senior Authorised Person**, then *ACR* precautions can be specified as precautions that may be varied.

Safety Distance shall not be infringed, on any **Equipment** specified in Section 1 of the **Sanction for Work** whilst *ACR* precautions are varied.

Appendix A - Example of a completed Safety Document.



PERMIT FOR WORK

NO. VOID

1. LOCATION Frodsham 400kV Substation EQUIPMENT IDENTIFICATION Disconnector 8T3 WORK TO BE DONE Disconnector Maintenance to RAMS ABC12345				
2. PRECAUTIONS TAKEN TO ACHIEVE SAFETY FROM THE SYSTEM Point(s) of Isolation At Frodsham 400kV Substation X814, X816, SGT8 400kV VT secondary supplies, SGT8 25kV VT secondary supplies. At Weaver Junction 25kV Substation Frodsham 8 25kV VT secondary supplies, 8L3 (Neutral Only) At Weaver Junction TFS Isolator WA/WN-F8/A, VT WA/WN-F8/VT/A1 Local Isolation 8T3 motor supply MCB lock off, 8T3 mag bolt isolation links, 8T3 Local/Remote locked in Local Primary Earths* At Frodsham 400kV Substation X 811C At Weaver Junction 25kV Substation 8L1C Actions taken to avoid Danger by draining, venting, purging and containment or dissipation of stored energy* N/A Further precautions to be taken during the course of the work to avoid System derived hazards* Work in Configuration G Area 2A: 8L3 and 8L1B immobilised, Ensure cable Sheath Bonding Links, Frodsham - Weaver Junction 8 section 1 side of link box 1/2 (CL2) and Frodsham 8 feeder links at Weaver Junction subststion (CL3) are removed before work commences. Drain earths to be applied in accordance with attached Earthing Schedule Work to be in accordance with ROMP/01				
3. PRECAUTIONS THAT MAY BE VARIED* 8T3 motor supply MCB lock off, 8T3 mag bolt isolation links				
4. PREPARATION This Permit for Work shall be personally retained				
Control Person(s) (Safety) giving Consent Andy SAP / Colin CPS			Key Safe Number* Frodsham 001	
Senior Authorised Person	Print Name Andy SAP	Signed	Time :	Date / /
5. ISSUE & RECEIPT			Key Safe Key Number* 001A	
Approved ROMP Procedure Numbers(s)* NGUK/PR/ETSR - ROMP/01		Earthing Schedule Number* AS010420141200		Portable Drain Earths (Number Issued)* 3
Safety Keys (Number issued)* 4	Senior Authorised Person Print Name Andy SAP		Signed	Senior Authorised Person Mobile No* 0799999999
Competent Person	Print Name Andy CP	Signed	Time :	Date / /
Company Name National Grid			Competent Person Mobile No*	0799999999

* Write N/A if not applicable

December 2007

Appendix B - Switching Instructions for Railway Connection Circuits

When **Equipment** is to be immobilised in accordance with this National Safety Instruction the **Control Person (Safety)** at the TNCC will issue one of the following instructions to a **Senior Authorised Person**

To ensure all *ACR* Safety Precautions Switching Instructions are clear and unambiguous standard terminology shall be adopted.

Some transposition of the words is permitted to achieve clear phraseology.

(- - -) Indicates the inclusion of the appropriate terms.

* Delete as appropriate

A) Creating a *Point of Immobilisation*

Instruction A Open (or check open) / remove, lock and apply “Do Not Close” / “Do Not Earth Conductors” Notice to *(---).

Entry on Safety Document (---)
(Further Precautions)

Disconnecter

The **Senior Authorised Person** shall:

After opening (or checking open) the disconnecter, remove motor supply links and place them within the compartment.

Remove the Lockout key and place it in the compartment with the motor supply links.

Attach a “Do Not Close Notice” and secure the compartment door closed with a safety lock.

Identify the **Safety Key(s)** and place them in a **Key Safe**.

A key safe key shall be removed from the **Key Safe** and placed in the operational key cabinet on the appropriate **equipment**.

Neutral link

The **Senior Authorised Person** shall:

After removing (or checking removed) the neutral link, remove the Lockout key.

Attach a “Do Not Close Notice” and secure the compartment door closed with a safety lock.

Identify the **Safety Key(s)** and place them in a **Key Safe**.

Earth Switch

The **Senior Authorised Person** shall:

Open (or check open) the Earth Switch

Attach a “Do Not Earth Conductors” Notice and secure the Earth Switch and the notice with a safety lock.

Identify the **Safety Key(s)** and place them in a **Key Safe**.

A key safe key shall be removed from the **Key Safe** and placed in the operational key cabinet on the appropriate **equipment**.

INE

The **Senior Authorised Person** shall:

After removing (or checking removed) the *INE* link, remove the Lockout key.

Attach a “Do Not Earth Conductors” and secure the compartment door closed with a safety lock.

Identify the **Safety Key(s)** and place them in a **Key Safe**.

B) Creating a *Point of Immobilisation* from an existing Point of Isolation

Instruction B Apply “Do Not Close” notice to (- - - -).

Entry on Safety Document (- - - -)
(Further Precautions)

The **Senior Authorised Person** shall:

Attach a “Do Not Close” notice through the safety lock on the relevant disconnecter or neutral link compartment door.

Identify on the **key safe** contents label that the **equipment** is now created as a point of immobilisation and a **Point of Isolation**.

C) Creating a Point of Isolation from an existing *Point of Immobilisation*

Instruction C Apply **caution** notice to (- - - -).

Entry on Safety Document (- - - -)

The **Senior Authorised Person** shall:

Attach a **caution** notice through the safety lock on the relevant disconnecter or neutral link compartment door.

Identify on the **key safe** contents label that the **equipment** is now created as a **Point of Isolation** and a point of immobilisation.

D) Making Equipment Available

Instruction D Remove “Do Not Close” / “Do Not Earth Conductors” notice and make available (- - -).

The **Senior Authorised Person** shall:

Disconnecter / Neutral link

Remove the **Safety Key(s)** from the **Key Safe** and

Remove the safety lock and “Do Not Close” notice from the compartment door.

For disconnectors, reinstate the Lockout Key and the motor supply links.

For Neutral links, reinstate the Lockout Key.

Earth Switch

Remove the **Safety Key(s)** from the **Key Safe** and

Remove the safety lock and the “Do Not Earth Conductors” notice from the Earthing Switch.

INE

Remove the **Safety Key(s)** from the **Key Safe** and

Remove the safety lock and “Do Not Earth Conductors” notice from the compartment door.

For Neutral links, reinstate the Lockout Key.

E) Making Equipment Available that will remain a Point of Isolation.

Instruction E Remove “Do Not Close” notice from (- - -).

The **Senior Authorised Person** shall:

Remove the “Do Not Close” notice from the disconnector or Neutral link compartment door which is to remain a **Point of Isolation**.

Remove the comment on the **key safe** contents label that the **equipment** a point of immobilisation and a **Point of Isolation**.

F) Rendering Operative Equipment that will remain a *Point of Immobilisation*

Instruction F Remove “Caution Notice” from (- - -).

The **Senior Authorised Person** shall:

Remove the **Caution Notice** from the disconnector or Neutral link compartment door that is to remain a *Point of Immobilisation*.

Remove the comment on the **key safe** contents label that the **equipment** a point of immobilisation and a **Point of Isolation**.

Appendix C - Configurations

Index

Configuration	Circuits Applicable (Locations)	Page
<i>Configuration A</i>	Rugeley 400kV – Brereton 25kV Harker 400kV – Harker 25kV	25
<i>Configuration B</i>	Elstree 400kV – Bushey 25kV	33
<i>Configuration C</i>	Patford Bridge 400kV – Long Buckby Wharf 25kV Patford Bridge 400kV - Patford Bridge 25kV	41
<i>Configuration D</i>	Leighton Buzzard 400kV – Leighton Buzzard 25kV	49
<i>Configuration E</i>	Poppleton 275kV - Poppleton 25kV	53
<i>Configuration F</i>	Wymondley 400kV – Coreys Mill 25kV	61
<i>Configuration G</i>	Frodsham 400kV – Weaver Junction 25kV	69
<i>Configuration H</i>	Hutton 400kV – Oxenholme 25kV	89
<i>Configuration I</i>	Elstree 400kV – Borehamwood 25kV	109
<i>Configuration J</i>	Barking132kV – Essex Road 25kV	113
<i>Configuration K</i>	Kensal Green 400kV – Kensal Green 25kV	121
<i>Configuration L</i>	Didcot 400kV - Foxhall Junction 25kV	125
<i>Configuration M</i>	Melksham 400kV – Thingley Junction 25kV	139
<i>Configuration N</i>	Pudding Mill Lane 400kV – Pudding Mill Lane 25kV	167
<i>Configuration P</i>	Ryhall 400kV – Essendine 25kV	171

CONFIGURATION A

CONFIGURATION A – AREA 1

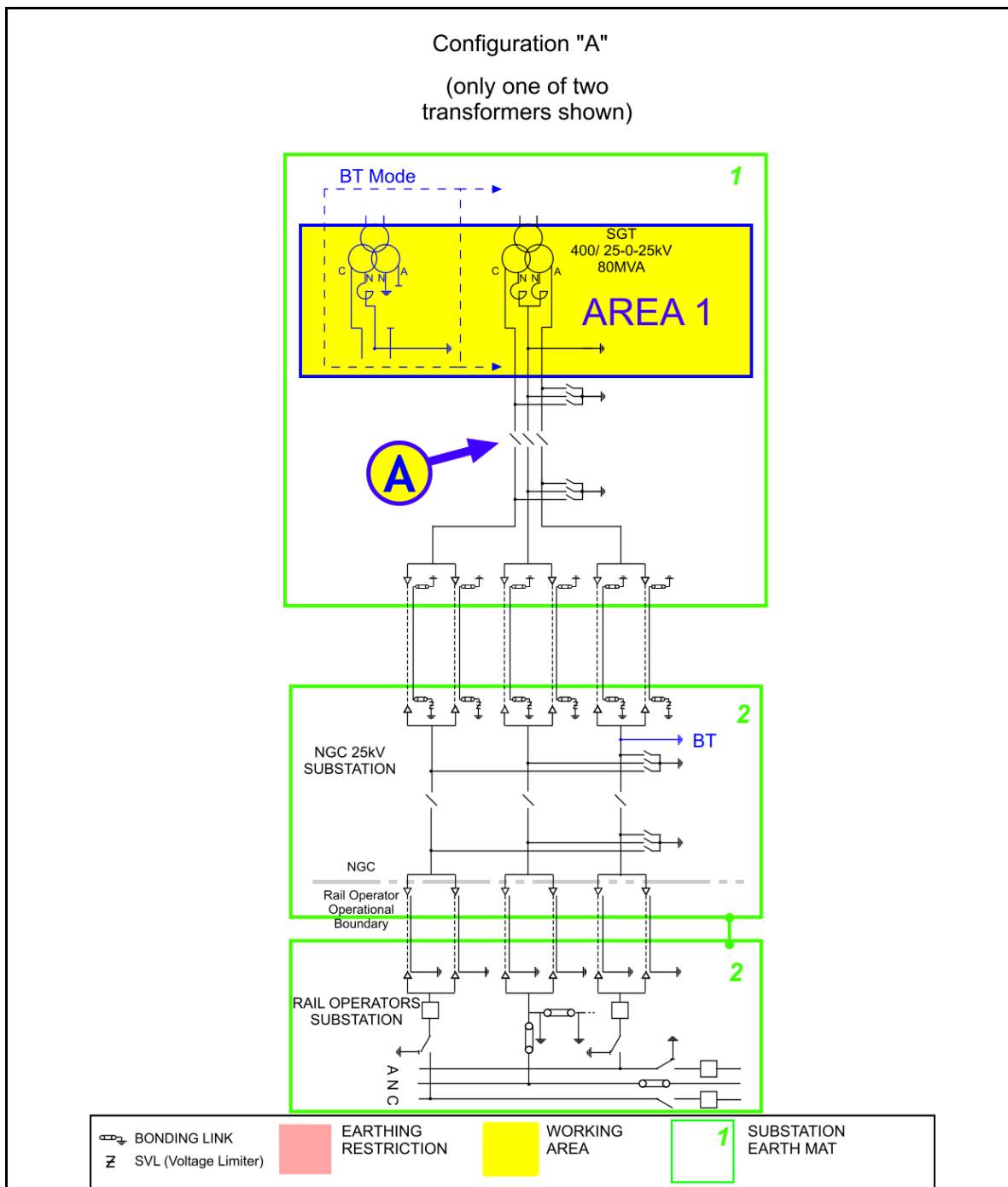

The following table is not a switching sequence. A **Senior Authorised Person** shall include the following tabulated precautions required on **Equipment** as part of a switching, isolating and earthing sequence to eliminate *ACR Current* from the designated working AREA.

AREA 1

Equipment	Precautions Required	Reason
Disconnecter A	Check, open, lock and apply the "Do Not Close Notice"	To prevent any <i>ACR Current</i> from finding a return path through the work area.

CONFIGURATION A – AREAS 2A AND 2B

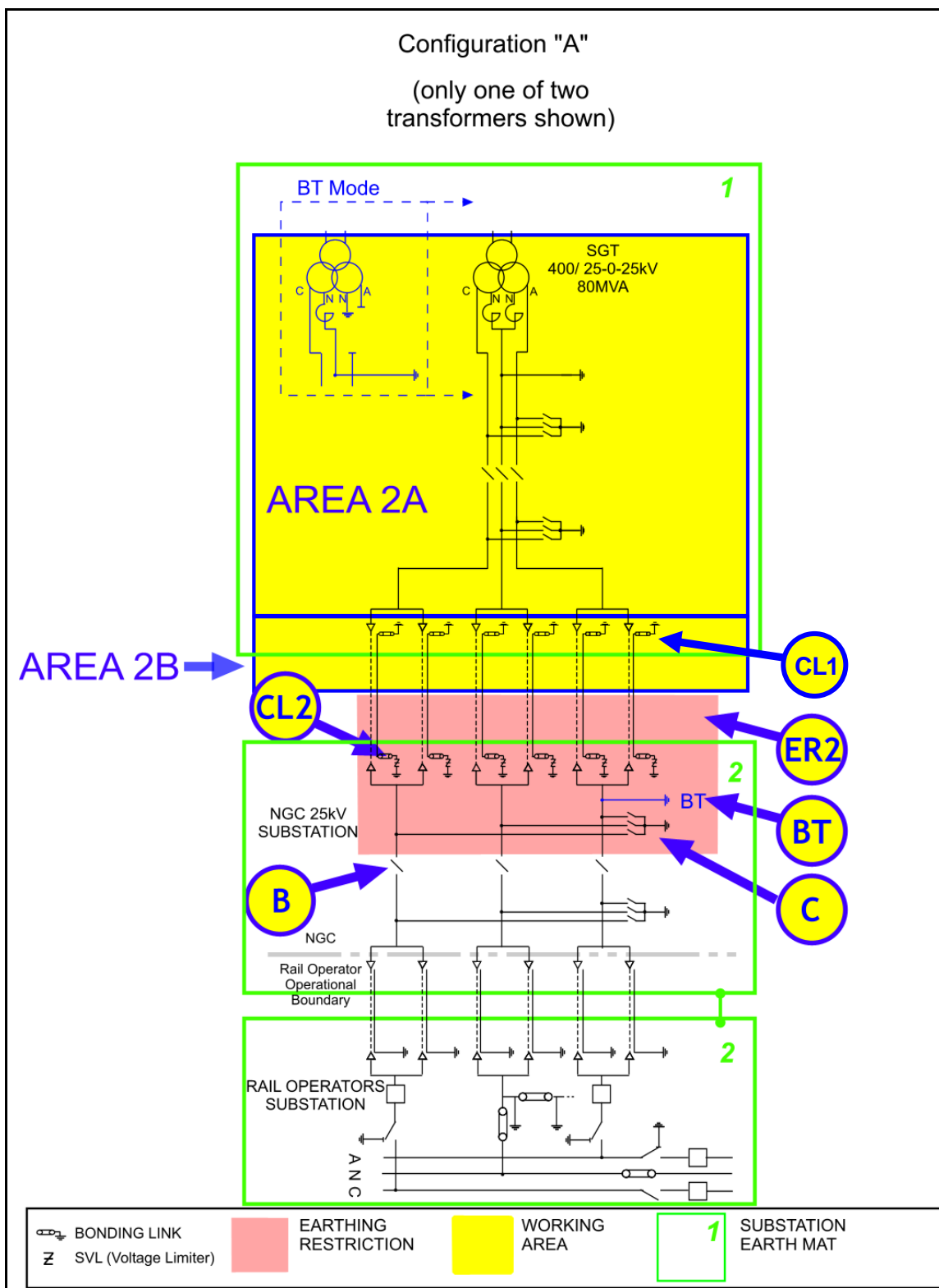

The following table is not a switching sequence. A **Senior Authorised Person** shall include the following tabulated precautions required on **Equipment** as part of a switching, isolating and earthing sequence to eliminate *ACR Current* from the designated working AREA.

AREA 2A

Equipment	Precautions Required	Reason
BT conductor earth, BT. (If Applicable)	Remove conductor earth, apply the "Do Not Earth Conductors Notice" A Permit will be required for this action.	Action is required to prevent <i>ACR Current</i> flowing along <i>A Pole</i> conductors when an earth is placed on the <i>A Pole</i> conductor in AREA 2A or 2B. Additional precautions may be necessary to avoid the Dangers of induced voltages. This earth must be in place if the circuit is to be energised in permanent <i>BT Mode</i> .
Disconnecter B	Check, open, lock and apply the "Do Not Close Notice"	Disconnect conductors from 25kV substation and rail operators System to stop <i>ACR Current</i> between earth mats via the <i>poles</i> and <i>Neutral Conductors</i> .
Earth Switch C	Open Earth Switch C and apply the "Do Not Earth Conductors Notice"	This precaution is necessary, as an earth on any of the <i>Poles</i> or <i>Neutral Conductor</i> will create a parallel path through which <i>ACR Current</i> will flow.
Earth restriction region ER2	Do not apply earths on Equipment inside regions ER2.	This precaution is necessary, as an earth on any of the <i>Poles</i> , <i>Neutral Conductor</i> or <i>Cable Sheath</i> will create a parallel path through which <i>ACR Current</i> will flow.

AREA 2B

If works are required on, or that could infringe a **Safety Distance** to, the cables, cable sealing ends or cable sheath connections then the following additional requirement to those for AREA 2A applies.

Cable sheath earth links CL2.	Remove cable sheath earth and bonding links Apply the "Do Not Earth Conductors Notice".	These links are to be removed in case the SVLs are not operating correctly. Removal of the links from all cables will prevent <i>ACR Current</i> flowing between the earth mats along the cable sheaths. NOTE: The cable bonding links "CL1" at the solidly bonded position shall be removed prior to removing / replacing the links "CL2" at an SVL position. "CL1" shall not be quoted as an ACR precaution.
-------------------------------	---	---

For guidance on the use of AREA 2B or AREA 3 refer to Section 4.3 of this document.

For multiple work locations on cables or their accessories refer to section 8.1 of this document.

CONFIGURATION A – AREA 3

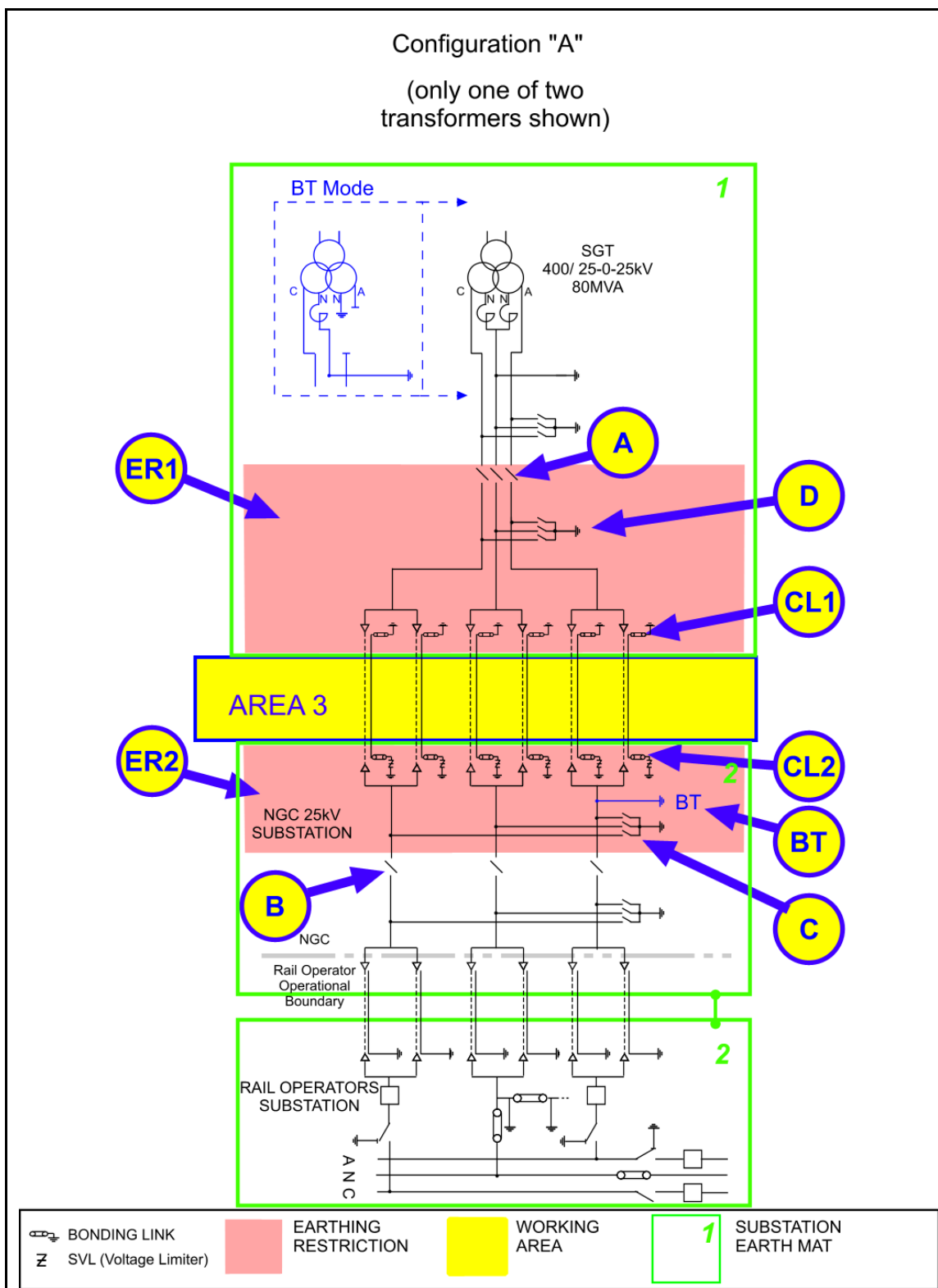

The following table is not a switching sequence. A **Senior Authorised Person** shall include the following tabulated precautions required on **Equipment** as part of a switching, isolating and earthing sequence to eliminate *ACR Current* from the designated working AREA.

AREA 3

Equipment	Precautions Required	Reason
BT conductor earth, BT. (If Applicable)	Remove conductor earth. Apply the "Do Not Earth Conductors Notice". A Permit will be required for this action.	This precaution is to prevent <i>ACR Current</i> flowing along <i>A Pole</i> conductors if an earth is placed on the <i>A Pole</i> conductor to the 400kV station mat. Additional precautions may be necessary to avoid the Dangers of induced voltages
Disconnectors A and B	Check, open, lock and apply the "Do Not Close Notice"	Avoid <i>ACR Current</i> in conductors between the 25kV and 400kV substations from the rail operator's System .
Earth Switches C and D	Open Earth Switches and apply the "Do Not Earth Conductors Notice"	This precaution is necessary to prevent <i>ACR Current</i> flowing along the cable and through the mass of earth when an earth is placed on a cable conductor or sheath in AREA 3.
<i>Earthing restriction zones</i> ER1 and ER2.	Do not apply earths on Equipment inside regions ER1 or ER2.	This precaution is necessary to prevent <i>ACR Current</i> flowing along the cable and through the mass of earth when an earth is placed on a cable conductor or sheath in AREA 3. The placing of an earth in the restricted regions ER3 or ER4 would create an alternative path for <i>ACR Current(s)</i> .
Cable sheath earth links, CL1 and CL2.	Remove cable sheath earth and bonding links Apply the "Do Not Earth Conductors Notice".	These links are to be removed in case the SVLs are not operating correctly. Removal of the links from all cables will prevent <i>ACR Current</i> flowing between the earth mats along the cable sheaths. The cable bonding links "CL1" at the solidly bonded position shall be removed prior to removing the links "CL2" at an SVL position. This will avoid <i>ACR Current(s)</i> flowing during the application of Earthing Devices .

For guidance on the use of AREA 2B, AREA 4B or AREA 3 refer to Section 4.3 of this document.

For multiple work locations on cables or their accessories refer to section 8.1 of this document.

CONFIGURATION A – AREA 4A & AREA 4B

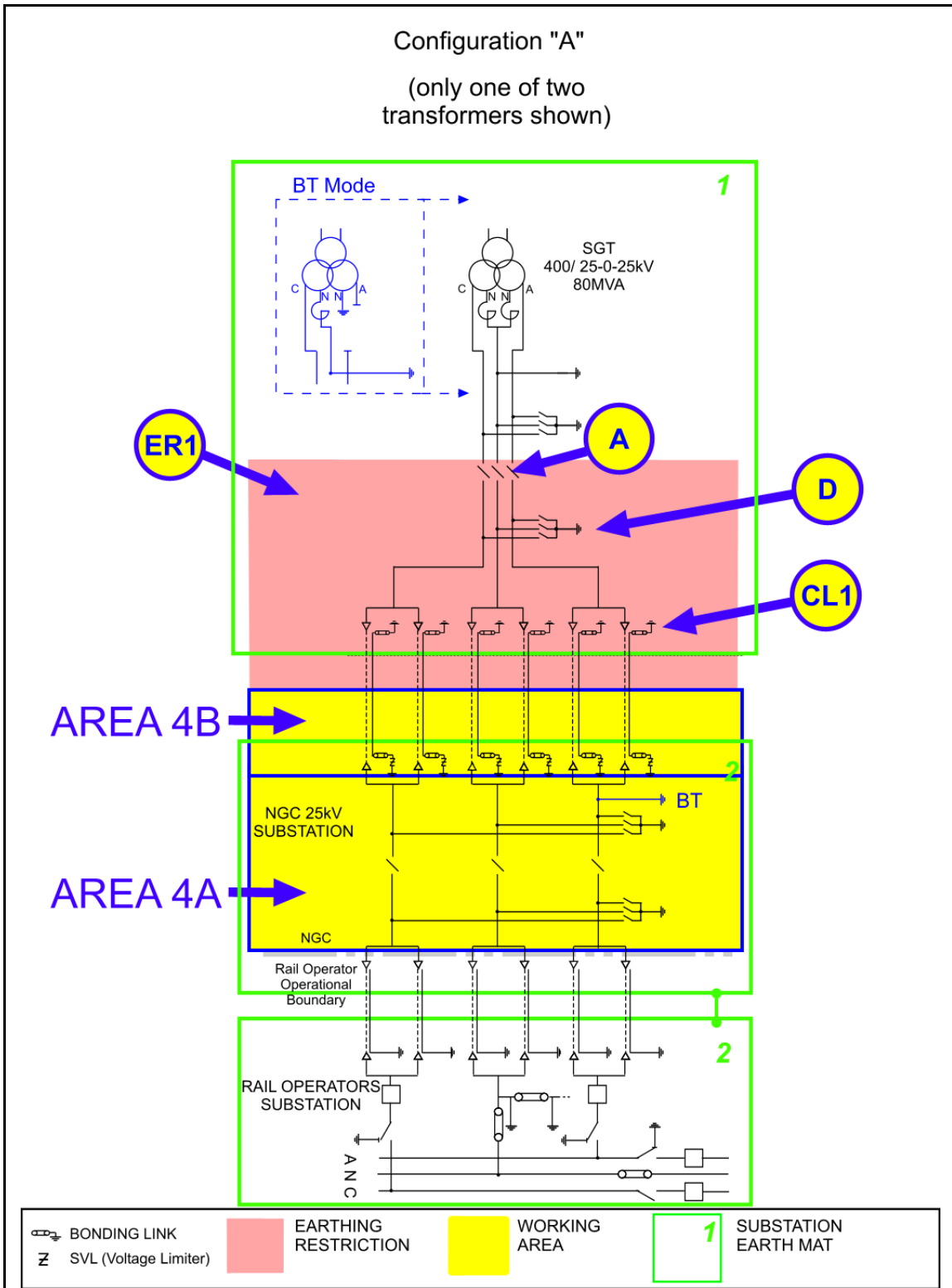

The following table is not a switching sequence. A **Senior Authorised Person** shall include the following tabulated precautions required on **Equipment** as part of a switching, isolating and earthing sequence to eliminate *ACR Current* from the designated working AREA.

AREA 4A

Equipment	Precautions Required	Reason
Disconnecter A	Check, open, lock and apply the "Do Not Close Notice"	Disconnect conductors from 25kV substation and rail operators system and stop <i>ACR Current</i> between earth mats, via the pole and <i>Neutral Conductors</i> , find a return path through the transformer earth.
Earth Switch D	Open Earth Switch D and apply the "Do Not Earth Conductors Notice".	This precaution is necessary to prevent <i>ACR Current</i> flowing along conductors if an earth is placed on a conductor, which would create a parallel path for <i>ACR Current(s)</i> .
<i>Earthing restriction zone</i> ER1.	Do not apply earths on Equipment inside region ER1.	This precaution is necessary to prevent <i>ACR Current</i> flowing along conductors if an earth is placed on a conductor, which would create a parallel path for <i>ACR Current(s)</i> .

AREA 4B

If works are required on, or that may infringe **Safety Distance** to, the Cables, Cable Sealing Ends or Cable Sheath connections then the following additional requirement to those for AREA 4A applies.

Cable sheath earth links, CL1.	Remove cable sheath bonding links. Apply the "Do Not Earth Conductors Notice".	These links are to be removed in case the SVLs are not operating correctly. Removal of the links from all cables will prevent <i>ACR Current</i> flowing between the earth mats along the cable sheaths. Additional precautions may be necessary to avoid the Dangers of impressed voltages (NSI 5). The links must be reinstalled before the circuit is energised.
--------------------------------	--	---

For guidance on the use of AREA 3 or AREA 4B refer to the guidance notes section 4.3.

For multiple work locations on cables or their accessories refer to section 8.1 of this document.

CONFIGURATION B
CONFIGURATION B – AREA 5

Configuration "B"
Only one of two transformers shown

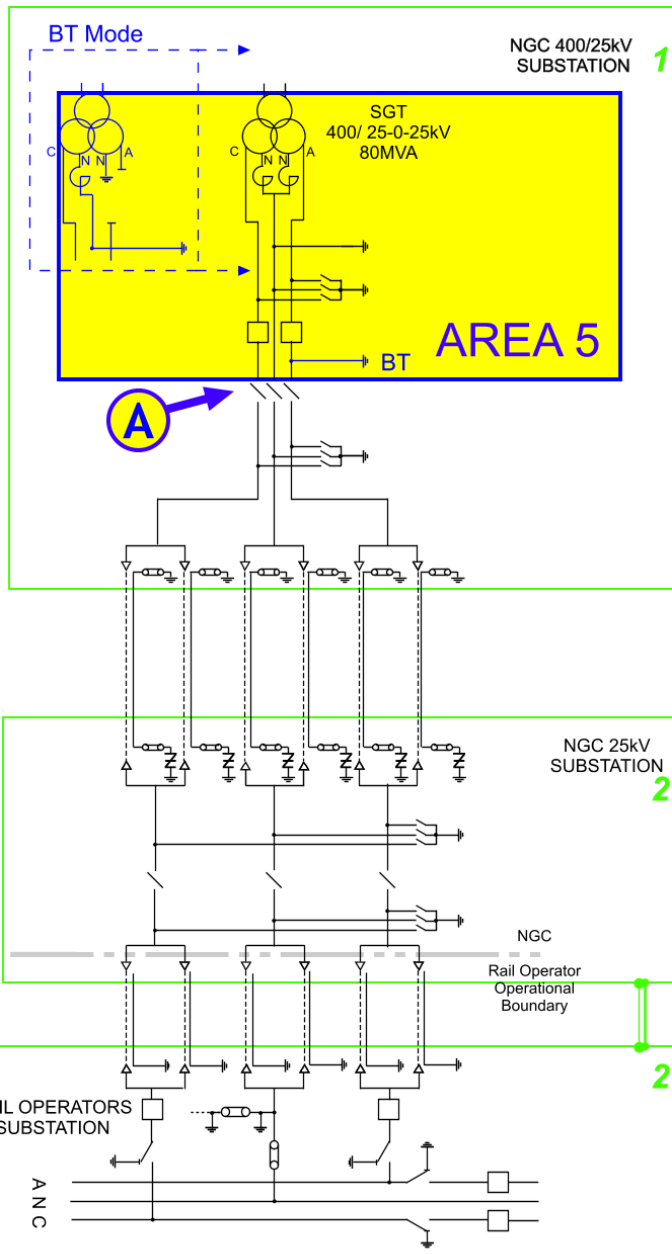

BONDING LINK	EARTHING RESTRICTION	WORKING AREA	SUBSTATION EARTH MAT
SVL (Voltage Limiter)			

The following table is not a switching sequence. A **Senior Authorised Person** shall include the following tabulated precautions required on **Equipment** as part of a switching, isolating and earthing sequence to eliminate *ACR Current* from the designated working AREA.

AREA 5

Equipment	Precautions Required	Reason
Disconnecter A	Check, open, lock and apply the "Do Not Close Notice"	To prevent any <i>ACR Current</i> from finding a return path through the work area.

CONFIGURATION B – AREAS 6 AND 2B

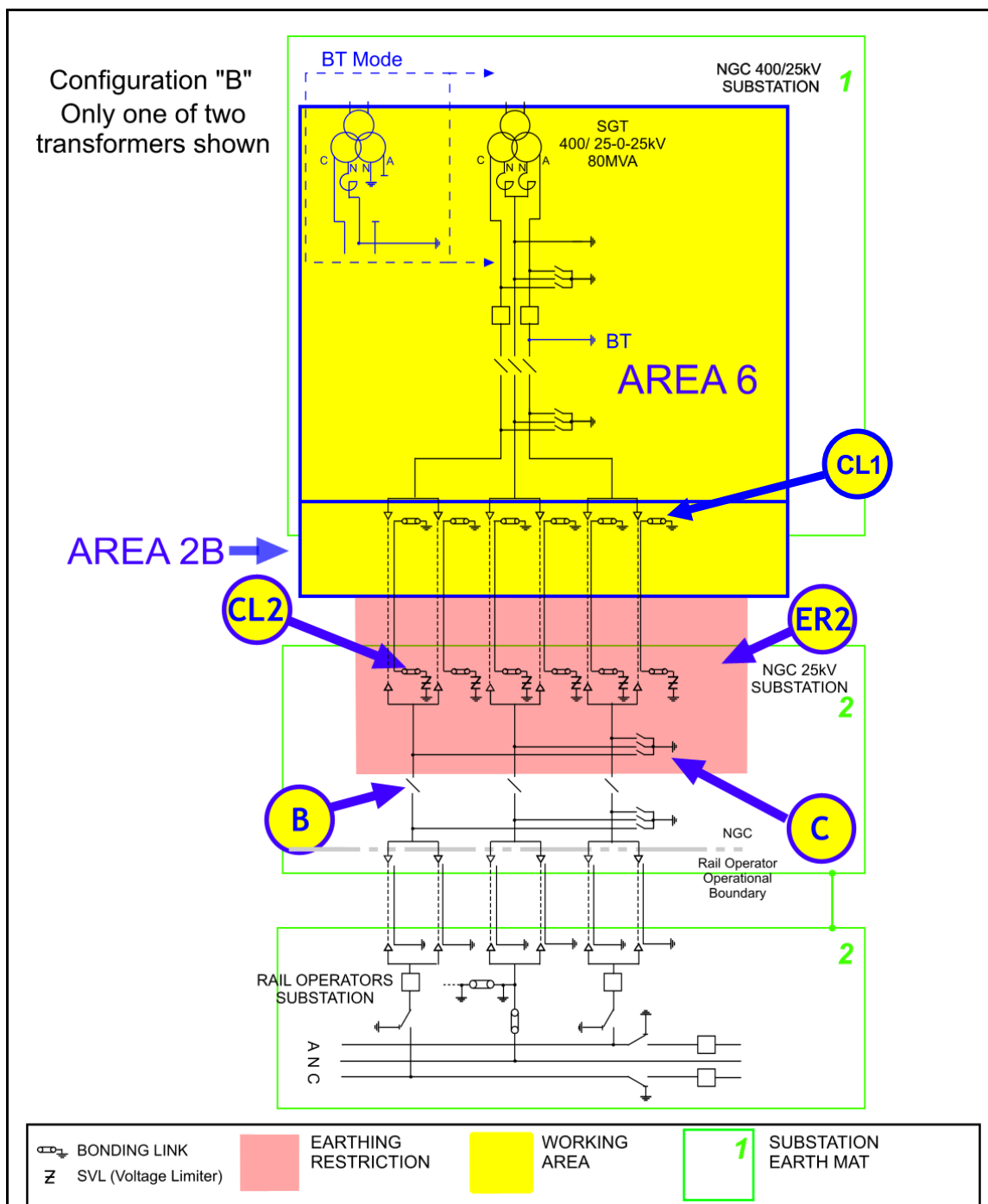

The following table is not a switching sequence. A **Senior Authorised Person** shall include the following tabulated precautions required on **Equipment** as part of a switching, isolating and earthing sequence to eliminate *ACR Current* from the designated working AREA.

AREA 6

Equipment	Precautions Required	Reason
Disconnecter B	Check, open, lock and apply the "Do Not Close Notice"	Disconnect conductors from 25kV substation and rail operators system to stop <i>ACR Current</i> between earth mats via the <i>poles</i> and <i>Neutral Conductors</i> .
Earth Switch C	Open Earth Switch C and apply the "Do Not Earth Conductors Notice"	This precaution is necessary, as an earth on any of the <i>Poles</i> or <i>Neutral Conductor</i> will create a parallel path through which <i>ACR Current</i> will flow.
Earth restriction region ER2	Do not apply earths on Equipment inside regions ER2.	This precaution is necessary, as an earth on any of the <i>Poles</i> , <i>Neutral Conductor</i> or Cable Sheath will create a parallel path through which <i>ACR Current</i> will flow.

AREA 2B

If works are required on, or that could infringe a **Safety Distance** to, the cables, cable sealing ends or cable sheath connections then the following additional requirement to those for AREA 6 applies.

Cable sheath earth links CL2.	Remove cable sheath earth and bonding links Apply the "Do Not Earth Conductors Notice".	These links are to be removed in case the SVLs are not operating correctly. Removal of the links from all cables will prevent <i>ACR Current</i> flowing between the earth mats along the cable sheaths. NOTE: The cable bonding links "CL1" at the solidly bonded position shall be removed prior to removing / replacing the links "CL2" at an SVL position. "CL1" shall not be quoted as an ACR precaution.
-------------------------------	---	---

For guidance on the use of AREA 2B or AREA 3 refer to Section 4.3 of this document.

For multiple work locations on cables or their accessories refer to section 8.1 of this document.

CONFIGURATION B – AREA 3

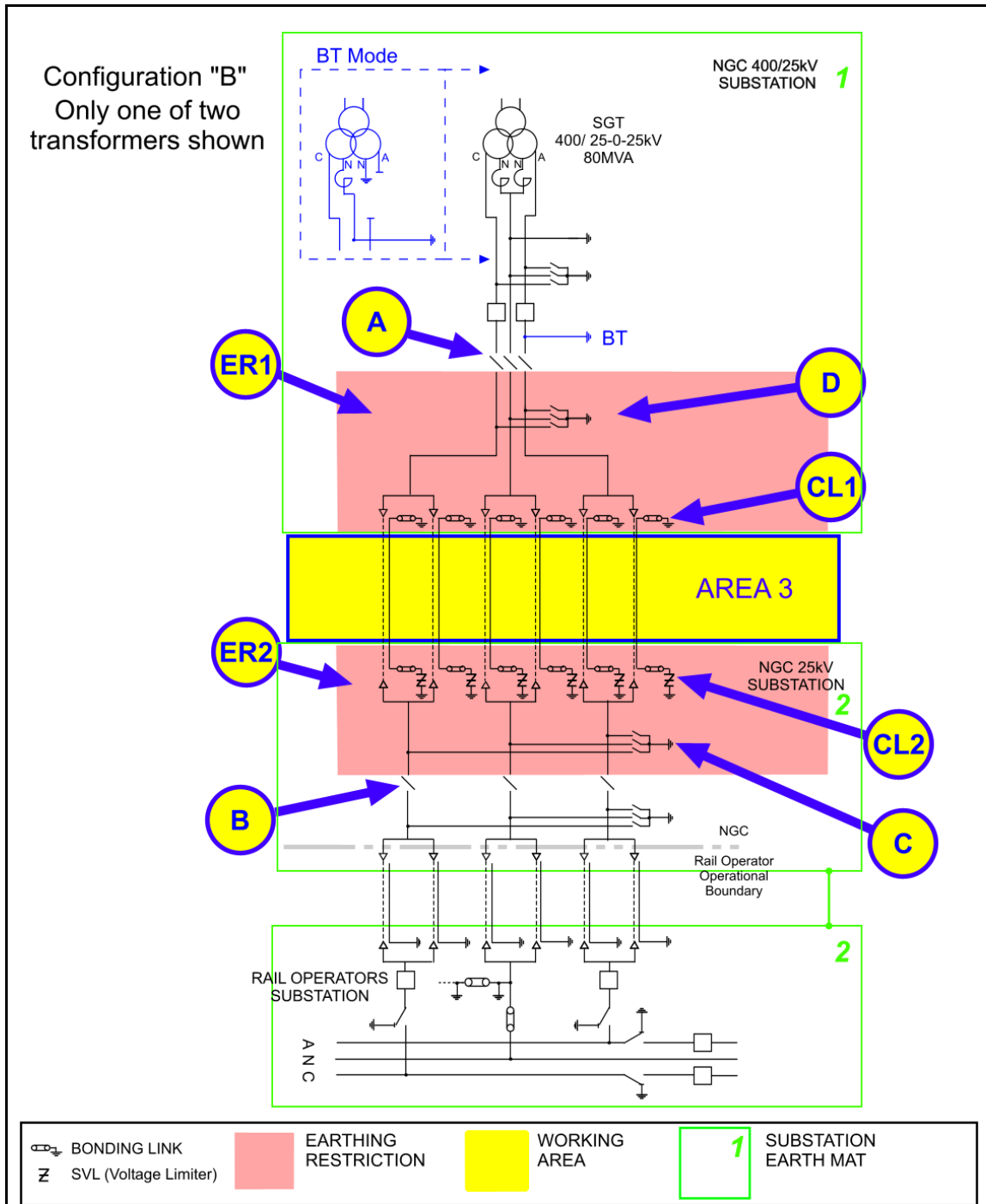

The following table is not a switching sequence. A **Senior Authorised Person** shall include the following tabulated precautions required on **Equipment** as part of a switching, isolating and earthing sequence to eliminate *ACR Current* from the designated working AREA.

AREA 3

Equipment	Precautions Required	Reason
Disconnectors A and B	Check, open, lock and apply the "Do Not Close Notice"	Avoid <i>ACR Current</i> in conductors between the 25kV and 400kV substations from the rail operator's system.
Earth Switches C and D	Open Earth Switches and apply the "Do Not Earth Conductors Notice"	This precaution is necessary to prevent <i>ACR Current</i> flowing along the cable and through the mass of earth when an earth is placed on a cable conductor or sheath in AREA 3.
<i>Earthing restriction zones</i> ER1 and ER2.	Do not apply earths on Equipment inside regions ER1 or ER2.	This precaution is necessary to prevent <i>ACR Current</i> flowing along the cable and through the mass of earth when an earth is placed on a cable conductor or sheath in AREA 3. The placing of an earth in the restricted regions ER3 or ER4 would create an alternative path for <i>ACR Current(s)</i> .
Cable sheath earth links, CL1 and CL2.	Remove cable sheath earth and bonding links. Apply the "Do Not Earth Conductors Notice".	<p>These links are to be removed in case the SVLs are not operating correctly. Removal of the links from all cables will prevent <i>ACR Current</i> flowing between the earth mats along the cable sheaths.</p> <p>The cable bonding links "CL1" at the solidly bonded position shall be removed prior to removing the links "CL2" at an SVL position.</p> <p>This will avoid <i>ACR Current(s)</i> flowing during the application of Earthing Devices.</p>

For guidance on the use of AREA 2B, AREA 4B or AREA 3 refer to Section 4.3 of this document.

For multiple work locations on cables or their accessories refer to section 8.1 of this document.

CONFIGURATION B – AREA 4

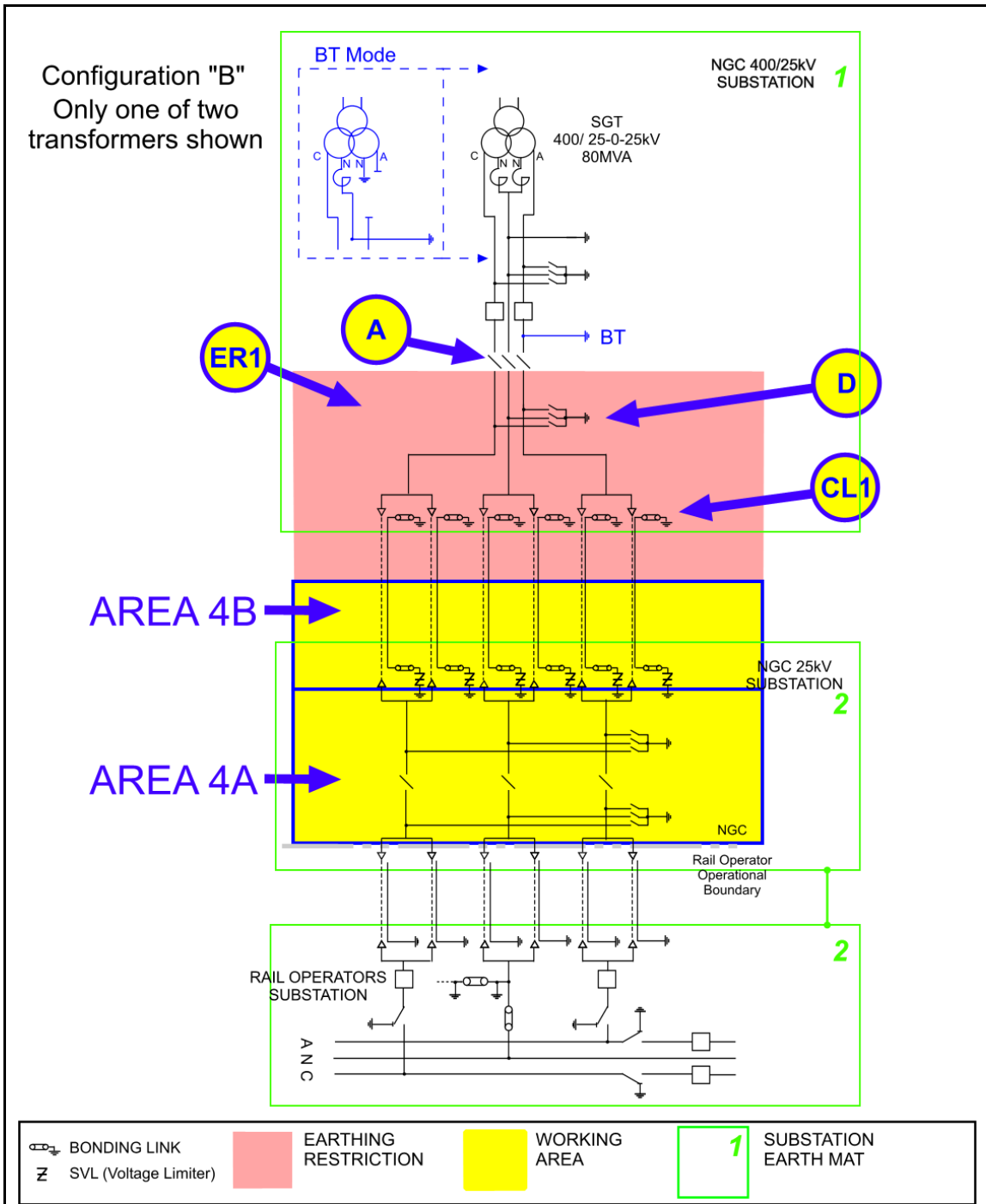

The following table is not a switching sequence. A **Senior Authorised Person** shall include the following tabulated precautions required on **Equipment** as part of a switching, isolating and earthing sequence to eliminate *ACR Current* from the designated working AREA.

AREA 4A

Equipment	Precautions Required	Reason
Disconnecter A	Check, open, lock and apply the "Do Not Close Notice"	Disconnect conductors from 25kV substation and rail operators system and stop <i>ACR Current</i> between earth mats, via the <i>poles</i> and <i>Neutral Conductors</i> , find a return path through the transformer earth.
Earth Switch D	Open Earth Switch D and apply the "Do Not Earth Conductors Notice".	This precaution is necessary to prevent <i>ACR Current</i> flowing along conductors if an earth is placed on a conductor, which would create a parallel path for <i>ACR Current(s)</i> .
<i>Earthing restriction zone</i> ER1.	Do not apply earths on Equipment inside region ER1.	This precaution is necessary to prevent <i>ACR Current</i> flowing along conductors if an earth is placed on a conductor, which would create a parallel path for <i>ACR Current(s)</i> .

AREA 4B

If works are required on, or that may infringe **Safety Distance** to, the Cables, Cable Sealing Ends or Cable Sheath connections then the following additional requirement to those for AREA 4A applies.

Cable sheath earth links, CL1.	Remove cable sheath bonding links. Apply the "Do Not Earth Conductors Notice".	These links are to be removed in case the SVLs are not operating correctly. Removal of the links from all cables will prevent <i>ACR Current</i> flowing between the earth mats along the cable sheaths. Additional precautions may be necessary to avoid the Dangers of impressed voltages (NSI 5). The links must be reinstalled before the circuit is energised.
--------------------------------	--	---

For guidance on the use of AREA 3 or AREA 4B refer to section 4.3 of this document.

For multiple work locations on cables or their accessories refer to section 8.1 of this document.

CONFIGURATION C CONFIGURATION C – AREA 7

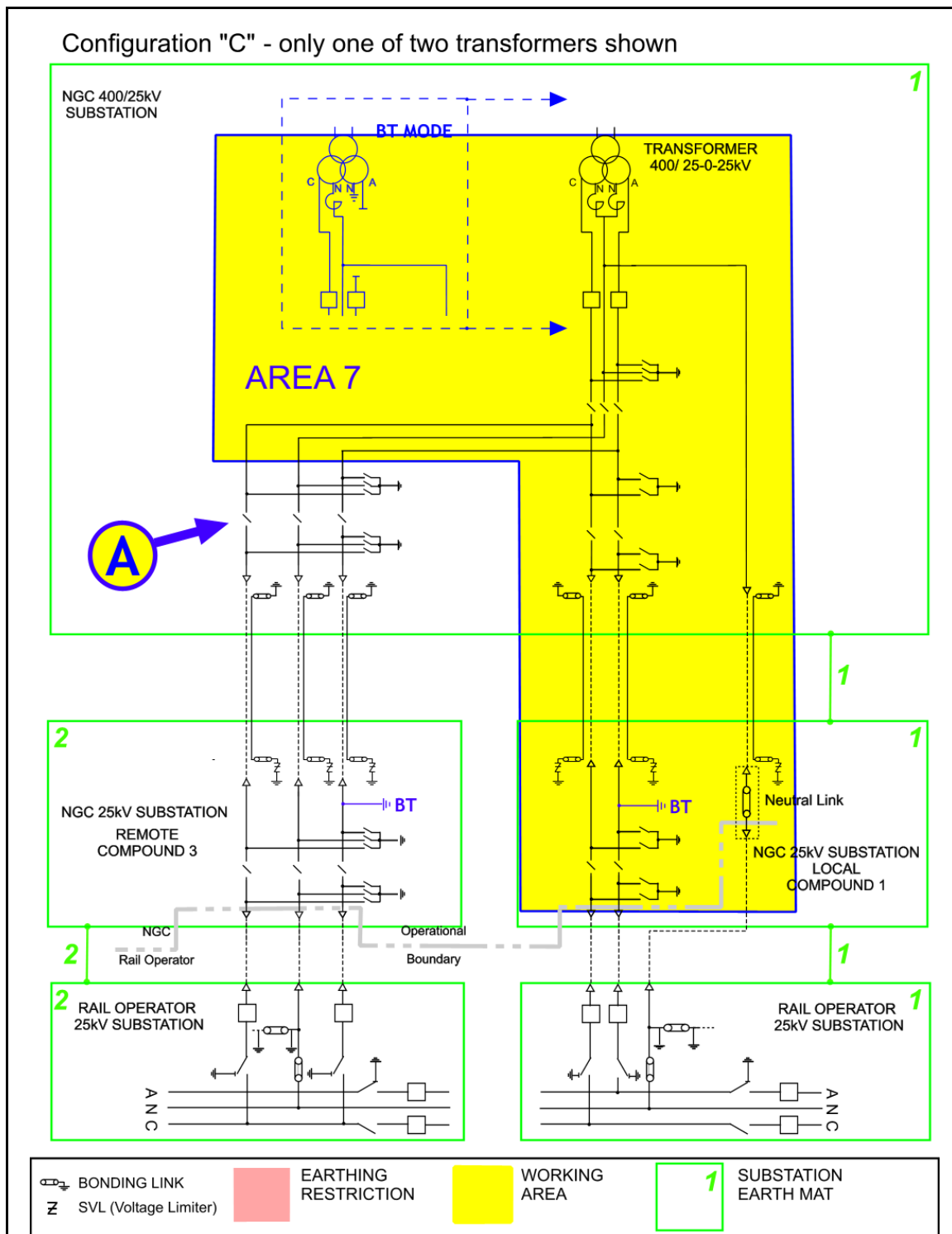

The following table is not a switching sequence. A **Senior Authorised Person** shall include the following tabulated precautions required on **Equipment** as part of a switching, isolating and earthing sequence to eliminate *ACR Current* from the designated working AREA.

AREA 7

Equipment	Precautions Required	Reason
Disconnecter A	Check, open, lock and apply the "Do Not Close Notice".	Avoid <i>ACR Current(s)</i> on conductors from compound 3 and rail operator's system finding a route through the work area.

CONFIGURATION C – AREA 8 AND 2B

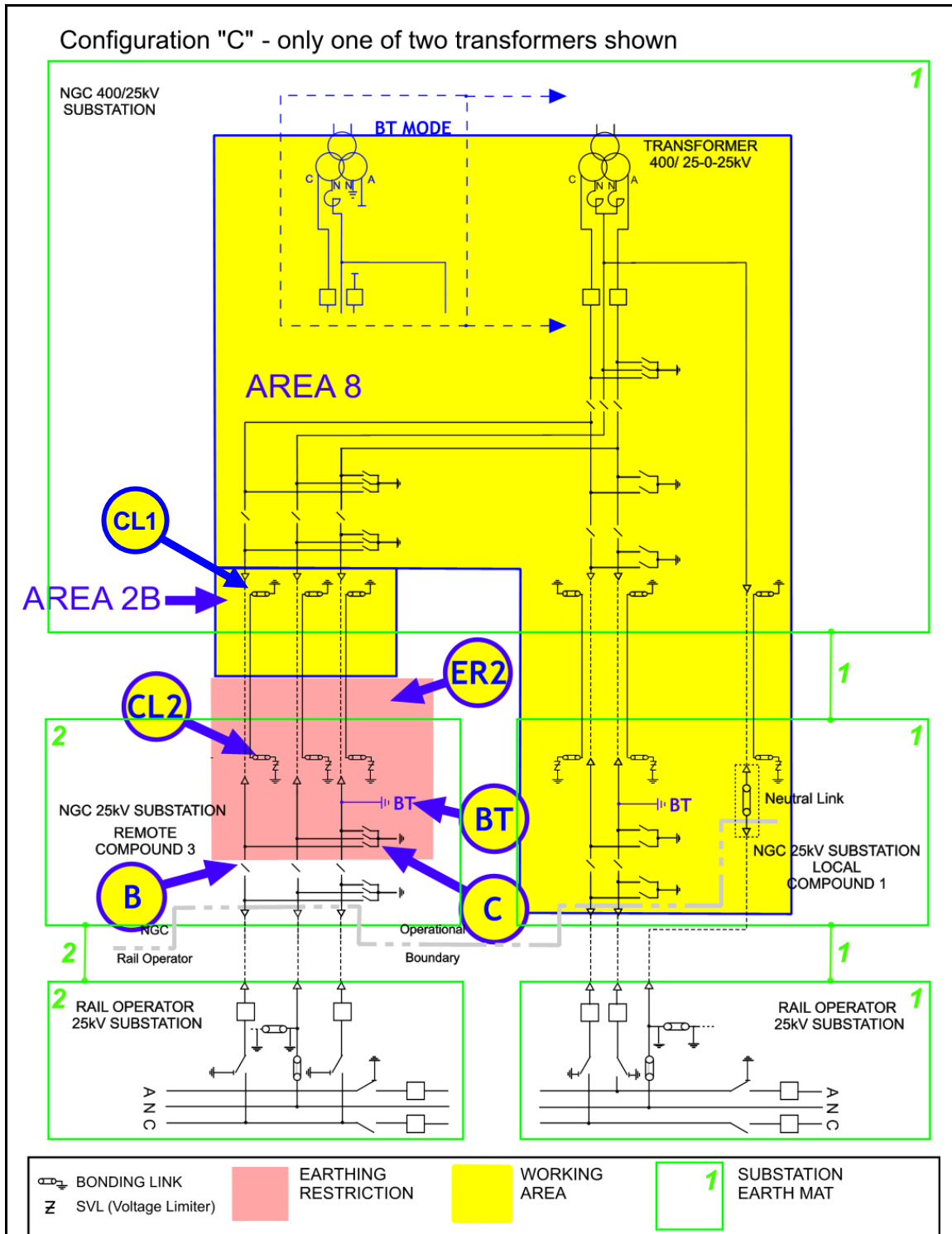

The following table is not a switching sequence. A **Senior Authorised Person** shall include the following tabulated precautions required on **Equipment** as part of a switching, isolating and earthing sequence to eliminate *ACR Current* from the designated working AREA.

AREA 8

Equipment	Precautions Required	Reason
BT conductor earth, BT. (If Applicable)	Remove conductor earth, apply the "Do Not Earth Conductors Notice" A Permit will be required for this action.	Action is required to prevent <i>ACR Current</i> flowing along <i>A Pole</i> conductors when an earth is placed on the <i>A Pole</i> conductor in AREA 8 or 2B. Additional precautions may be necessary to avoid the Dangers of induced voltages. This earth must be in place if the circuit is to be energised in permanent <i>BT Mode</i> .
Disconnecter B	Check, open, lock and apply the "Do Not Close Notice"	Disconnect conductors from 25kV substation and rail operators system to stop <i>ACR Current</i> between earth mats via the pole and <i>Neutral Conductors</i> .
Earth Switch C	Open Earth Switch C and apply the "Do Not Earth Conductors Notice"	This precaution is necessary, as an earth on any of the Poles or <i>Neutral Conductor</i> will create a parallel path through which <i>ACR Current</i> will flow.
Earth restriction region ER2	Do not apply earths on Equipment inside regions ER2.	This precaution is necessary, as an earth on any of the Poles, <i>Neutral Conductor</i> or Cable Sheath will create a parallel path through which <i>ACR Current</i> will flow.

AREA 2B

If works are required on, or that could infringe a **Safety Distance** to, the cables, cable sealing ends or cable sheath connections then the following additional requirement to those for AREA 8 applies.

Cable sheath earth links CL2.	Remove cable sheath earth and bonding links Apply the "Do Not Earth Conductors Notice".	These links are to be removed in case the SVLs are not operating correctly. Removal of the links from all cables will prevent <i>ACR Current</i> flowing between the earth mats along the cable sheaths. NOTE: The cable bonding links "CL1" at the solidly bonded position shall be removed prior to removing / replacing the links "CL2" at an SVL position. "CL1" shall not be quoted as an ACR precaution.
-------------------------------	---	---

For guidance on the use of AREA 2B or AREA 3 refer to section 4.3 of this document.

For multiple work locations on cables or their accessories refer to section 8.1 of this document.

CONFIGURATION C – AREA 3

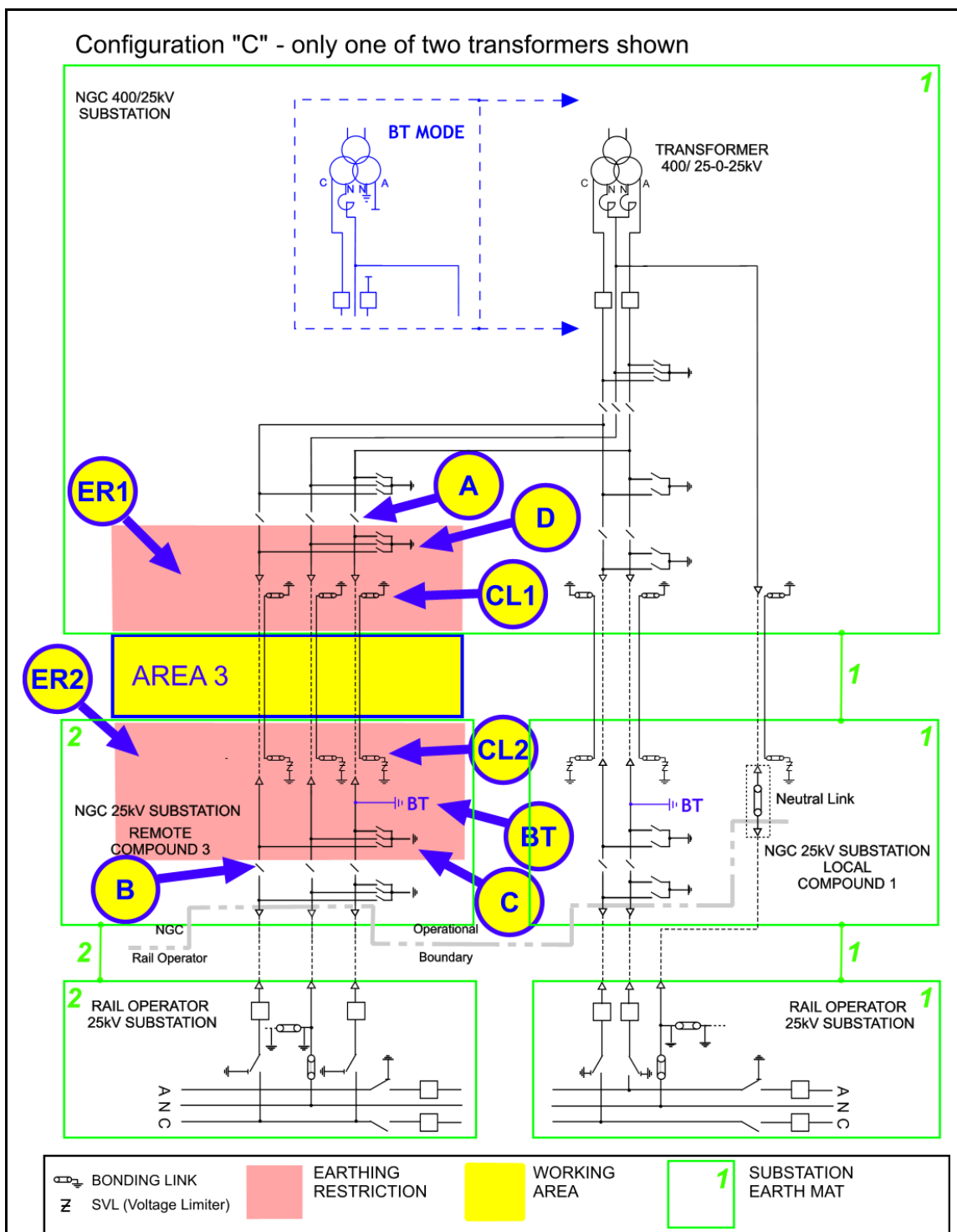

The following table is not a switching sequence. A **Senior Authorised Person** shall include the following tabulated precautions required on **Equipment** as part of a switching, isolating and earthing sequence to eliminate *ACR Current* from the designated working AREA.

AREA 3

Equipment	Precautions Required	Reason
BT conductor earth, BT. (If Applicable)	Remove conductor earth. Apply the “Do Not Earth Conductors Notice”. A Permit will be required for this action.	This precaution is to prevent <i>ACR Current</i> flowing along <i>A Pole</i> conductors if an earth is placed on the <i>A Pole</i> conductor to the 400kV station mat. Additional precautions may be necessary to avoid the Dangers of induced voltages
Disconnectors A and B	Check, open, lock and apply the “Do Not Close Notice”	Avoid <i>ACR Current</i> in conductors between the 25kV and 400kV substations from the rail operator’s system.
Earth Switches C and D	Open Earth Switches and apply the “ Do Not Earth Conductors Notice”	This precaution is necessary to prevent <i>ACR Current</i> flowing along the cable and through the mass of earth when an earth is placed on a cable conductor or sheath in AREA 3.
<i>Earthing restriction zones</i> ER1 and ER2.	Do not apply earths on Equipment inside regions ER1 or ER2.	This precaution is necessary to prevent <i>ACR Current</i> flowing along the cable and through the mass of earth when an earth is placed on a cable conductor or sheath in AREA 3. The placing of an earth in the restricted regions ER3 or ER4 would create an alternative path for <i>ACR Current(s)</i> .
Cable sheath earth links, CL1 and CL2.	Remove cable sheath earth and bonding links. Apply the “Do Not Earth Conductors Notice”.	These links are to be removed in case the SVLs are not operating correctly. Removal of the links from all cables will prevent <i>ACR Current</i> flowing between the earth mats along the cable sheaths. The cable bonding links “CL1” at the solidly bonded position shall be removed prior to removing the links “CL2” at an SVL position. This will avoid <i>ACR Current(s)</i> flowing during the application of Earthing Devices .

For guidance on the use of AREA 2B, AREA 4B or AREA 3 refer to section 4.3 of this document.

For multiple work locations on cables or their accessories refer to section 8.1 of this document.

CONFIGURATION C – AREA 4A AND 4B

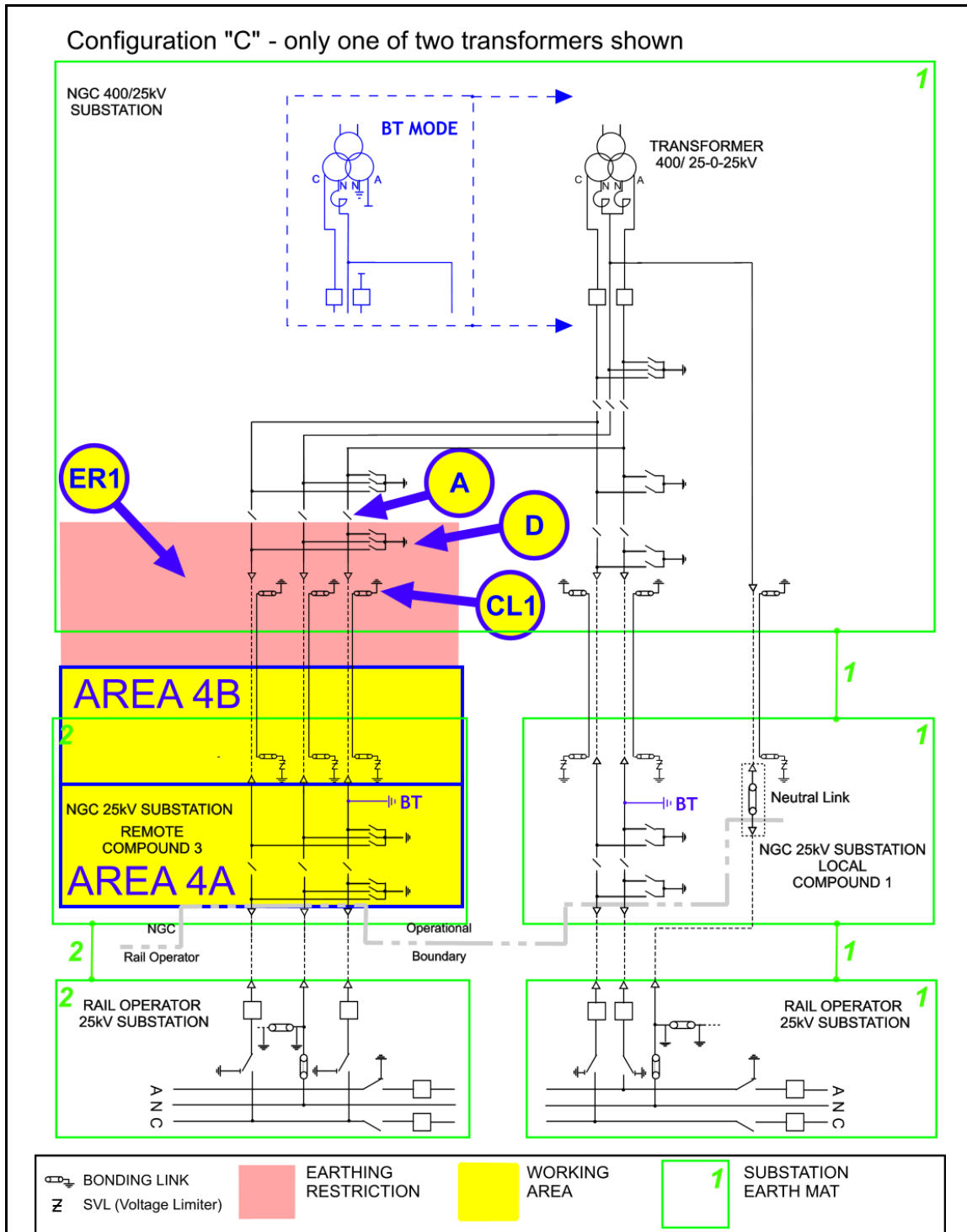

The following table is not a switching sequence. A **Senior Authorised Person** shall include the following tabulated precautions required on **Equipment** as part of a switching, isolating and earthing sequence to eliminate *ACR Current* from the designated working AREA.

AREA 4A

Equipment	Precautions Required	Reason
Disconnecter A	Check, open, lock and apply the "Do Not Close Notice"	Disconnect conductors from 25kV substation and rail operators system and stop <i>ACR Current</i> between earth mats, via the pole and <i>Neutral Conductors</i> , find a return path through the transformer earth.
Earth Switch D	Open Earth Switch D and apply the "Do Not Earth Conductors Notice".	This precaution is necessary to prevent <i>ACR Current</i> flowing along conductors if an earth is placed on a conductor, which would create a parallel path for <i>ACR Current(s)</i> .
<i>Earthing restriction zone</i> ER1.	Do not apply earths on Equipment inside region ER1.	This precaution is necessary to prevent <i>ACR Current</i> flowing along conductors if an earth is placed on a conductor, which would create a parallel path for <i>ACR Current(s)</i> .

AREA 4B

If works are required on, or that may infringe **Safety Distance** to, the Cables, Cable Sealing Ends or Cable Sheath connections then the following additional requirement to those for AREA 4A applies.

Cable sheath earth links, CL1.	Remove cable sheath bonding links. Apply the "Do Not Earth Conductors Notice".	These links are to be removed in case the SVL's are not operating correctly. Removal of the links from all cables will prevent <i>ACR Current</i> flowing between the earth mats along the cable sheaths. Additional precautions may be necessary to avoid the Dangers of impressed voltages (NSI 5). The links must be reinstalled before the circuit is energised.
--------------------------------	--	--

For guidance on the use of AREA 3 or AREA 4B refer to section 4.3 of this document.

For multiple work locations on cables or their accessories refer to section 8.1 of this document.

CONFIGURATION D CONFIGURATION D – AREA 9

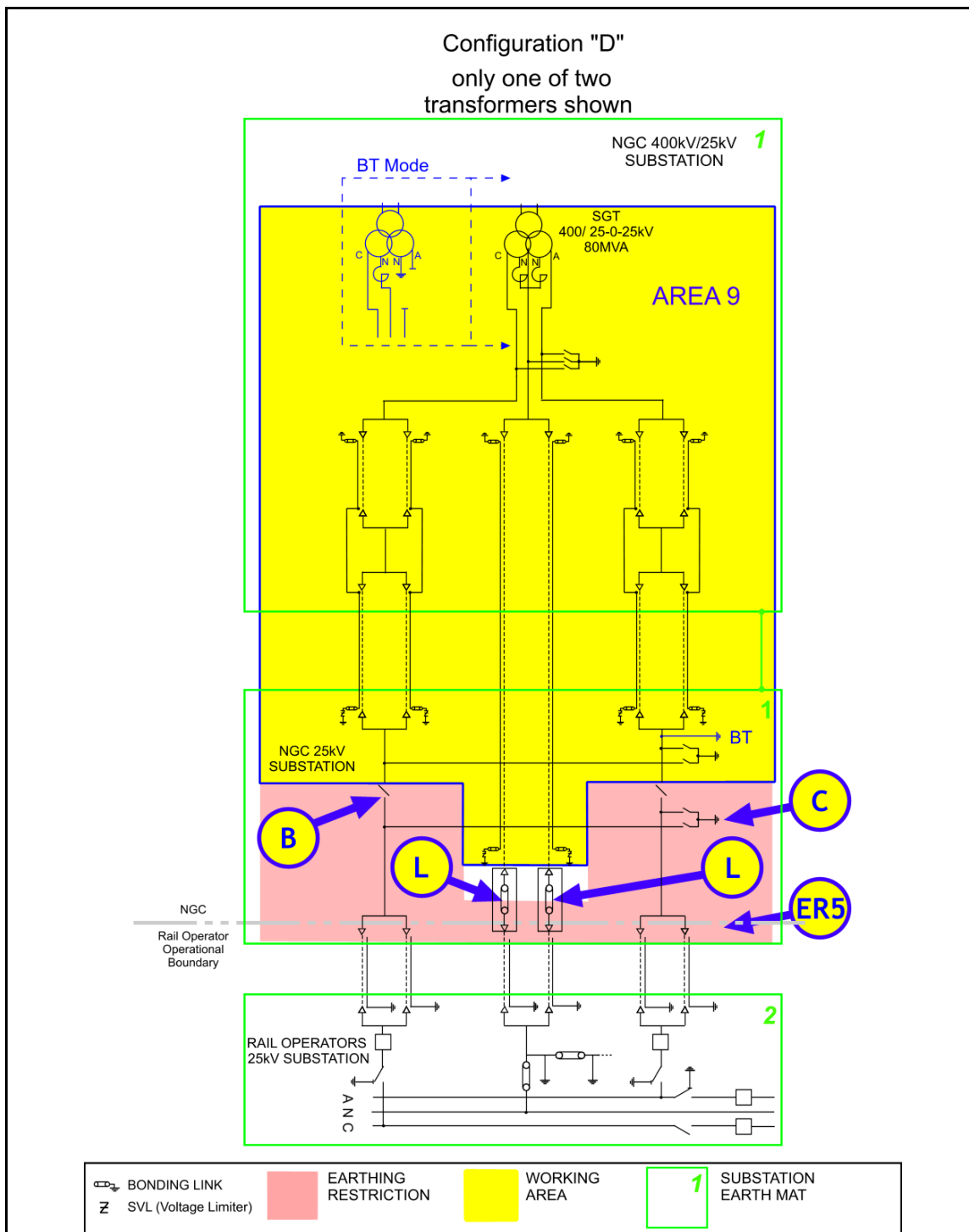

The following table is not a switching sequence. A **Senior Authorised Person** shall include the following tabulated precautions required on **Equipment** as part of a switching, isolating and earthing sequence to eliminate *ACR Current* from the designated working AREA.

AREA 9

Equipment	Precautions Required	Reason
Disconnecter B	Check, open, lock and apply the "Do Not Close Notice"	To stop any <i>ACR</i> current flow through the point of work and the <i>C</i> and <i>A poles</i> as a result of any earths being placed on pole conductors in the rail operators system.
Earth Switch C	Open Earth Switch C and apply the "Do Not Earth Conductors Notice"	To stop any <i>ACR</i> current flow through the point of work and the <i>C</i> and <i>A poles</i> as a result of any earths being placed on pole conductors in the rail operators system.
Neutral earth links L.	Remove Link L and apply the "Do Not Close Notice". Place a "Do Not Earth Conductors Notice" on the Rail Operator's Side of the Neutral Link.	To stop any <i>ACR</i> current flow through the point of work and the <i>Neutral Conductor</i> as a result of any earths being placed on the <i>Neutral Conductor</i> in the rail operators system. Prior to removal or replacement of the NGC neutral link, the rail operators earth connection to the neutral conductor must be removed. This is required in order to avoid problems with high <i>ACR</i> current when applying or removing an earth on the NGC neutral link as part of the link removal or replacement procedure. The Rail Operator's side of the open link must not be earthed to the NGT mat as <i>ACR</i> current would flow should the Neutral conductor also be earthed to the Rail Operator's earth mat.
<i>Earthing restriction zone</i> ER5.	No earths to be placed on conductors.	During maintenance works in AREA 9 it may be necessary to apply an earth to one or more of the conductors. If an earth were also to be placed on the same conductor in region ER5 then <i>ACR</i> current could flow along conductors upon which maintenance is being performed.

Note

The above precautions do protect against *ACR* current but in this arrangement with the transformer neutral earthed at the Rail Operators site the precautions also protect against *EPR/RoEP* on the NG side being exported to Rail Operators system.

CONFIGURATION D – AREA 10

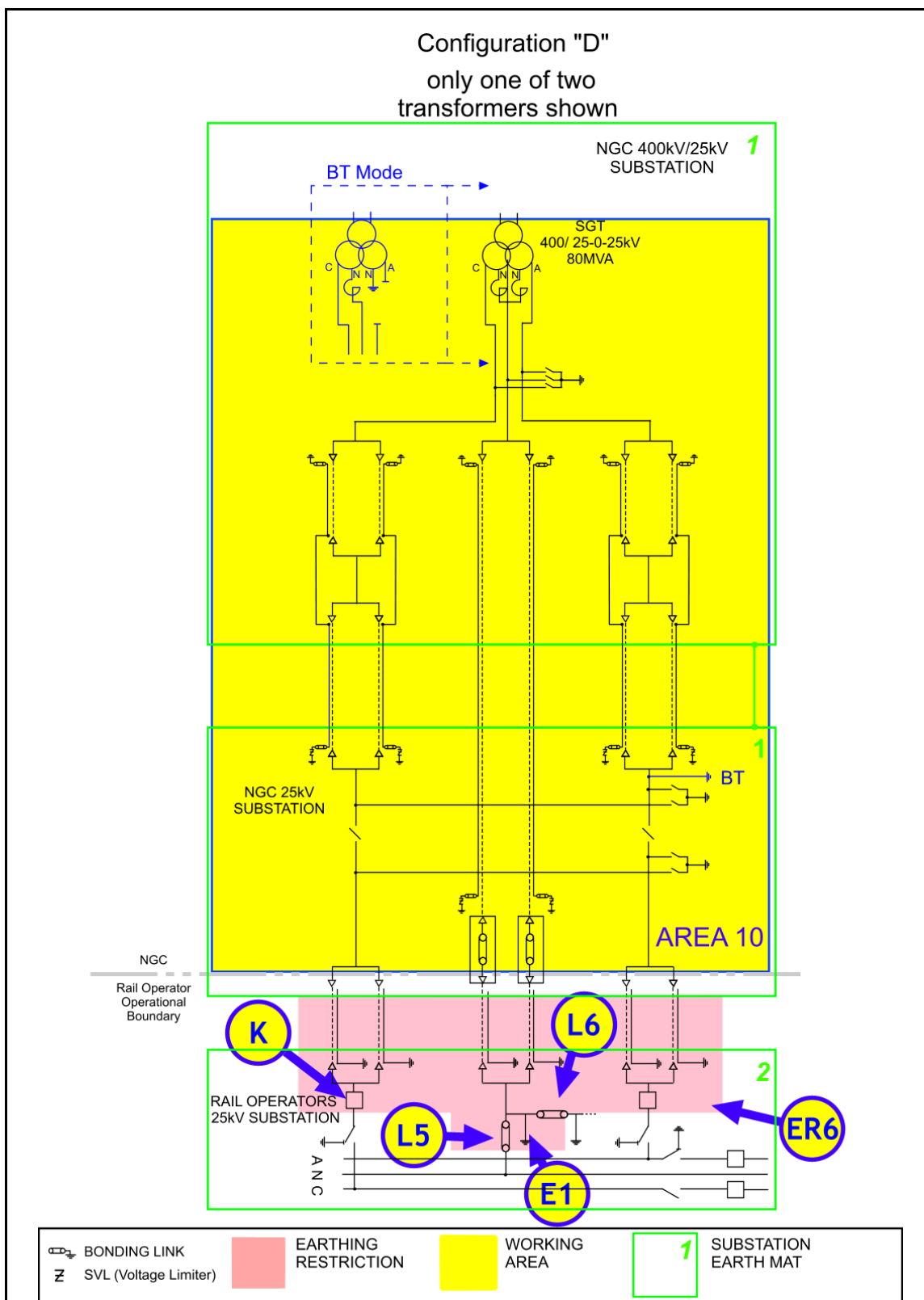

The following table is not a switching sequence. A **Senior Authorised Person** shall include the following tabulated precautions required on **Equipment** as part of a switching, isolating and earthing sequence to eliminate *ACR Current* from the designated working AREA.

AREA 10

Equipment	Precautions Required	Reason
Rail operator's equipment Circuit breaker K	Locked open	To stop any <i>ACR</i> current flow through the point of work and the <i>C</i> and <i>A poles</i> as a result of any earths being placed on pole conductors in the rail operators system.
Rail operator's equipment. Links L5, L6 and Earth Connection E1	Remove rail operator neutral links and earths.	To stop any <i>ACR</i> current flow through the point of work and the <i>Neutral Conductor</i> as a result of earths on the rail operators system.
<i>Earthing restriction zone</i> ER6	No earths to be placed on the NGC side of rail operators disconnectors and neutral link removals	During maintenance works in AREA 10 it may be necessary to apply an earth to one or more of the conductors. If an earth were also to be placed on the same conductor in region ER6 then <i>ACR</i> current could flow along conductors upon which maintenance is being performed.

Note:

The above precautions do protect against *ACR* current but in this arrangement with the transformer neutral earthed at the Rail Operators site the precautions also protect against *EPR/RoEP* on the NG side being exported to Rail Operators system.

CONFIGURATION E CONFIGURATION E – AREA 11

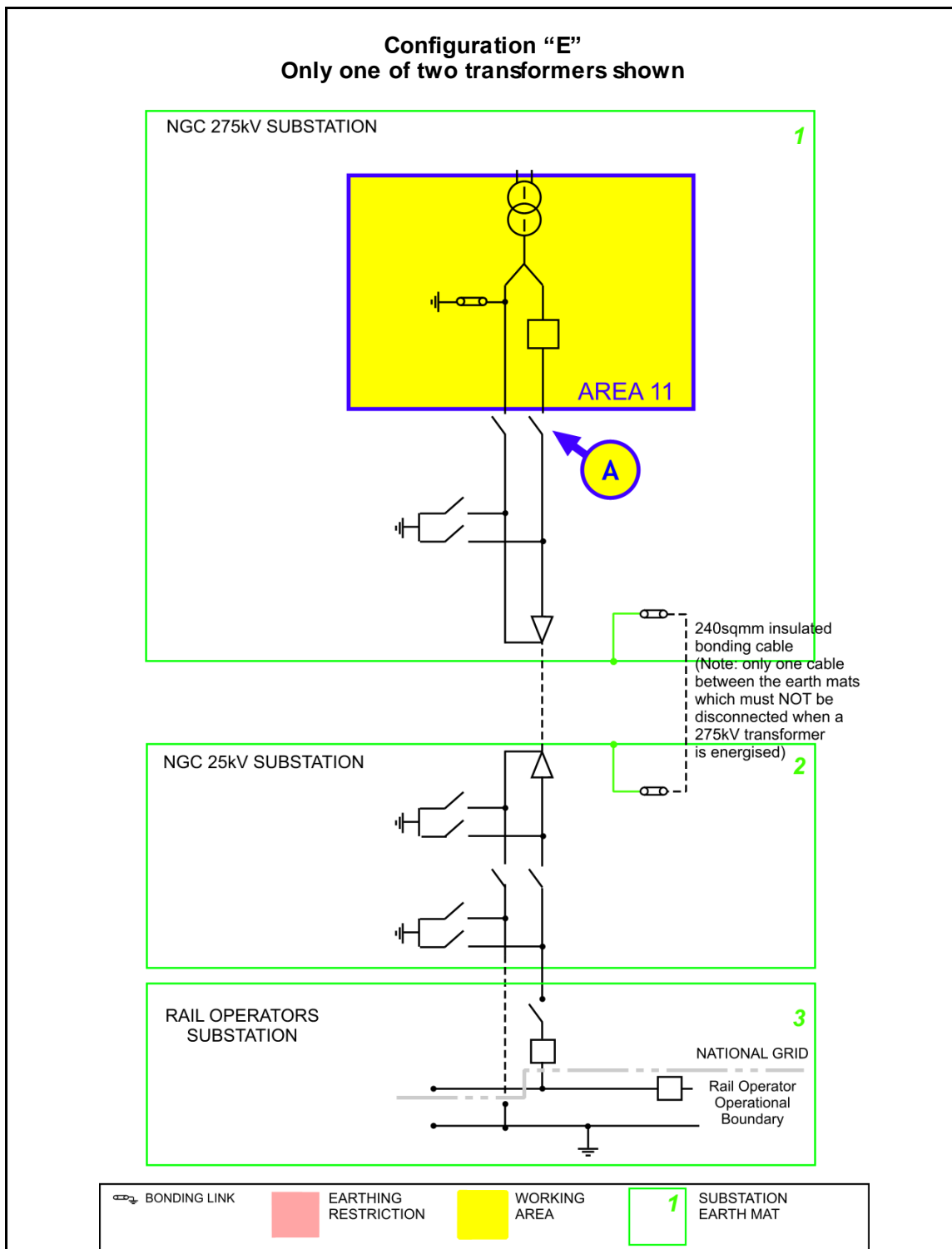

The following table is not a switching sequence. A **Senior Authorised Person** shall include the following tabulated precautions required on **Equipment** as part of a switching, isolating and earthing sequence to eliminate *ACR Current* from the designated working AREA.

AREA 11

Equipment	Precautions Required	Reason
Disconnecter A	Check, open, lock and apply the "Do Not Close Notice"	To stop any <i>ACR</i> current flow through the point of work and the <i>C</i> and <i>N poles</i> as a result of any earths being placed on pole conductors of system.

CONFIGURATION E – AREA 12A AND AREA 12B

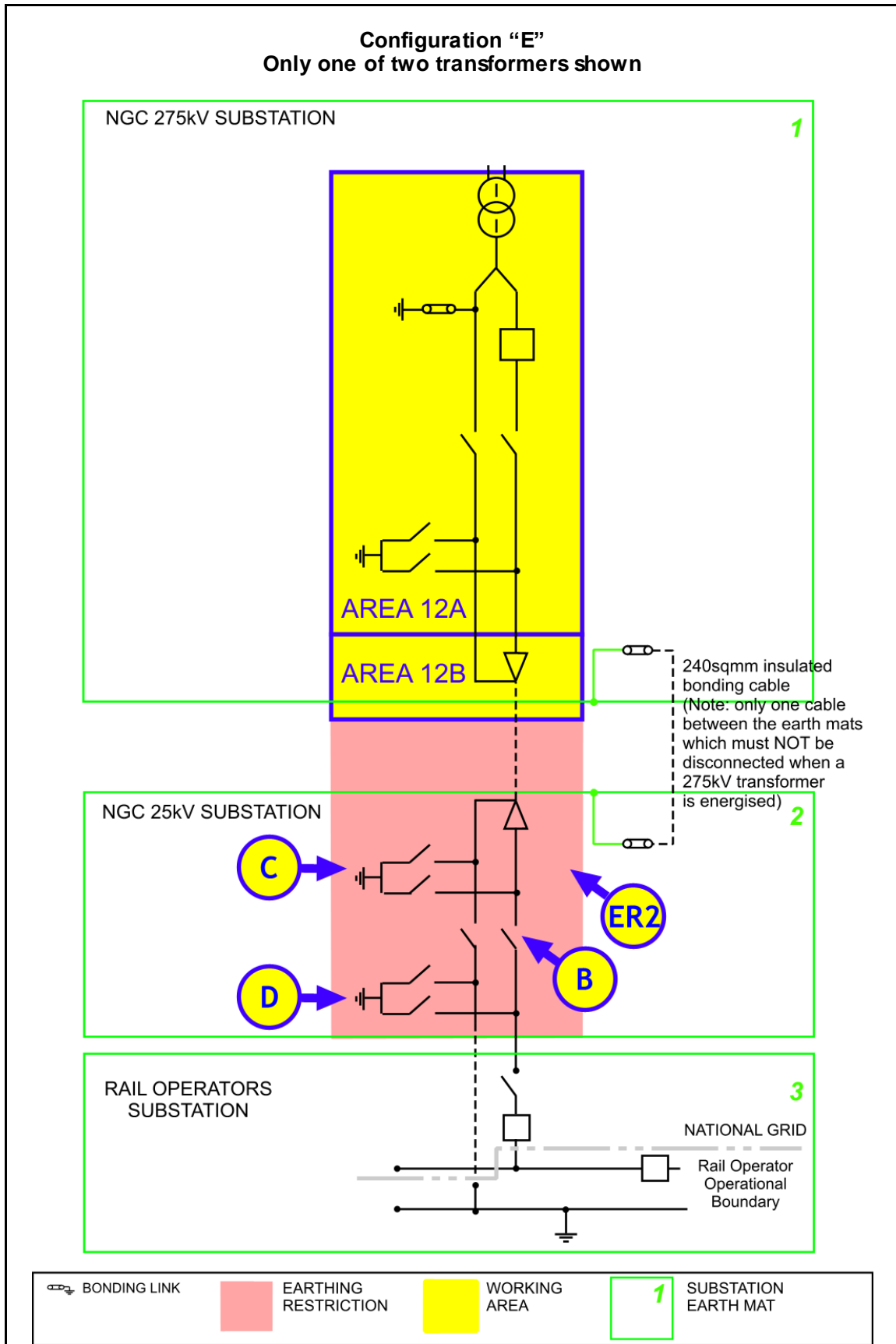

The following table is not a switching sequence. An **Senior Authorised Person** shall include the following tabulated precautions required on **Equipment** as part of a switching, isolating and earthing sequence to eliminate *ACR Current* from the designated working AREA.

AREA 12A and AREA 12B

Equipment	Precautions Required	Reason
Disconnecter B	Check, open, lock and apply the "Do Not Close Notice"	To stop any <i>ACR</i> current flow through the point of work and the <i>C</i> and <i>N poles</i> as a result of any earths being placed on pole conductors of system.
Earth Switch C	Open Earth Switch C and apply the "Do Not Earth Conductors Notice"	To stop any <i>ACR</i> current flowing through the work area.
Earth Switch D	Open Earth Switch D and apply the "Do Not Earth Conductors Notice"	To stop any <i>ACR</i> current flowing through the work area or through insulated bonding cable. The closing of this earth switch will create an <i>ACR</i> current path.
<i>Earthing restriction zone</i> ER2	No earths to be placed on any equipment within the <i>earthing restriction zone</i> .	During maintenance works in AREA 12A or AREA 12B it may be necessary to apply an earth to one or more of the conductors. If an earth were also to be placed on the same conductor in region ER2 then <i>ACR</i> current could flow along conductors upon which maintenance is being performed.

AREA 12B ONLY

If works are required on, or that may infringe **Safety Distance** to, the Cables, Cable Sealing Ends or Cable Sheath connections then, in addition to the requirements for AREA 12A, the 25kV power cable sheath and cable joint coverings of the in-service cable shall be confirmed to be intact by testing.

CONFIGURATION E – AREA 13

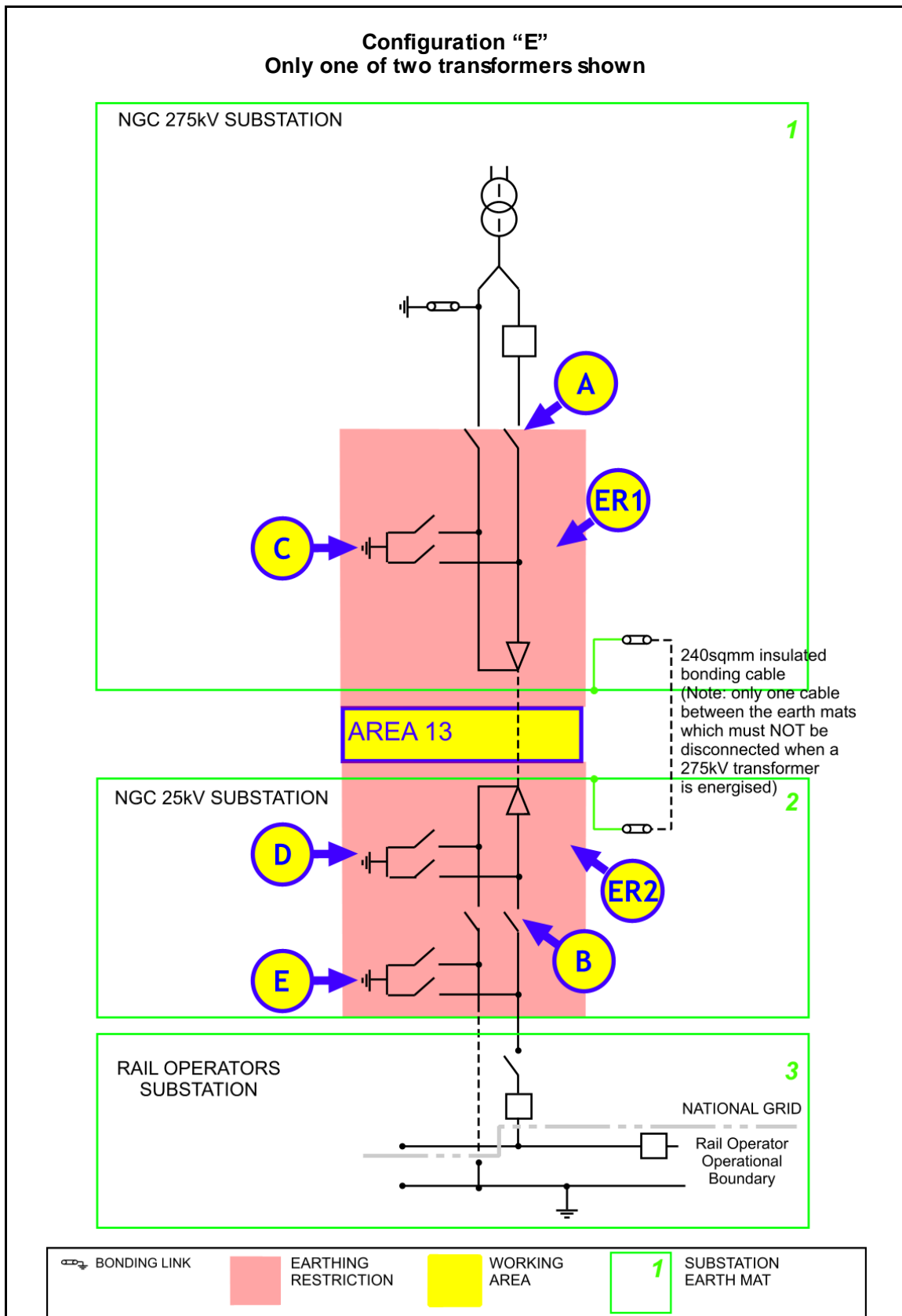

The following table is not a switching sequence. A **Senior Authorised Person** shall include the following tabulated precautions required on **Equipment** as part of a switching, isolating and earthing sequence to eliminate *ACR Current* from the designated working AREA.

AREA 13

Equipment	Precautions Required	Reason
Disconnecter A	Check, open, lock and apply the "Do Not Close Notice"	To stop any <i>ACR</i> current flow through the point of work and the <i>C</i> and <i>N poles</i> as a result of any earths being placed on pole conductors of system.
Disconnecter B	Check, open, lock and apply the "Do Not Close Notice"	To stop any <i>ACR</i> current flow through the point of work and the <i>C</i> and <i>N poles</i> as a result of any earths being placed on pole conductors of system.
Earth Switch C	Open Earth Switch C and apply the "Do Not Earth Conductors Notice"	To stop any <i>ACR</i> current flowing through the work area or increased <i>ACR</i> current through insulated bonding cable.
Earth Switch D	Open Earth Switch D and apply the "Do Not Earth Conductors Notice"	To stop any <i>ACR</i> current flowing through the work area or through insulated bonding cable. The closing of this earth switch will create an <i>ACR</i> current path.
Earth Switch E	Open Earth Switch E and apply the "Do Not Earth Conductors Notice"	To stop any <i>ACR</i> current flowing through the work area or increased <i>ACR</i> current through insulated bonding cable.
<i>Earthing restriction zone</i> ER1	No earths to be placed on any equipment within the <i>earthing restriction zone</i> .	During maintenance works it may be necessary to apply an earth to one or more of the cable conductors. If an earth were also to be placed on the same conductor in region ER1 then <i>ACR</i> current could flow along conductors upon which maintenance is being performed.
<i>Earthing restriction zone</i> ER2	No earths to be placed on any equipment within the <i>earthing restriction zone</i> .	During maintenance works it may be necessary to apply an earth to one or more of the cable conductors. If an earth were also to be placed on the same conductor in region ER2 then <i>ACR</i> current could flow along conductors upon which maintenance is being performed.

For multiple work locations on cables or their accessories refer to section 8.1 of this document.

CONFIGURATION E – AREA 14

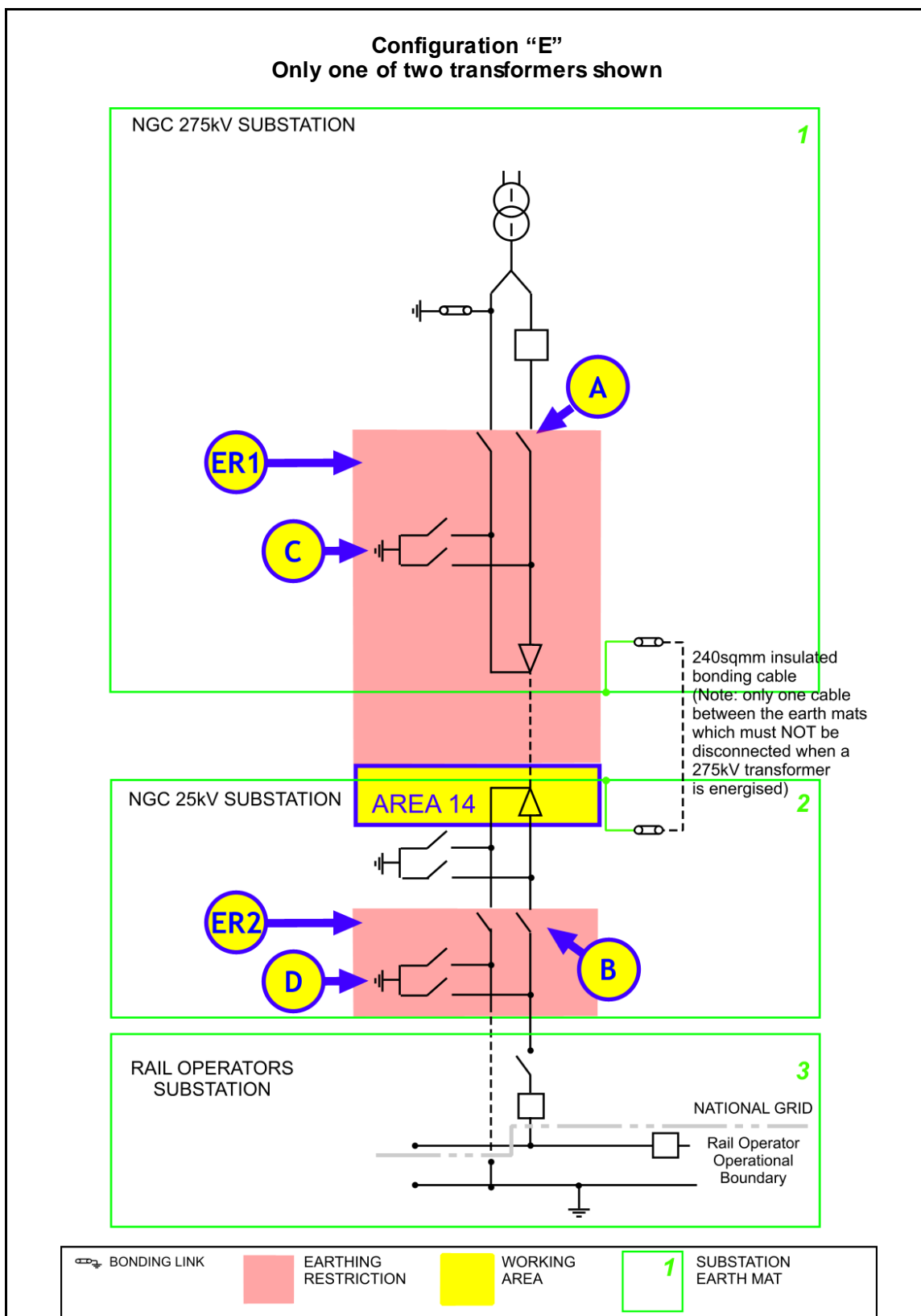

The following table is not a switching sequence. A **Senior Authorised Person** shall include the following tabulated precautions required on **Equipment** as part of a switching, isolating and earthing sequence to eliminate *ACR Current* from the designated working AREA.

AREA 14

Equipment	Precautions Required	Reason
Disconnecter A	Check, open, lock and apply the "Do Not Close Notice"	To stop any <i>ACR</i> current flow through the point of work and the <i>C</i> and <i>N poles</i> as a result of any earths being placed on pole conductors of system.
Disconnecter B	Check, open, lock and apply the "Do Not Close Notice"	To stop any <i>ACR</i> current flow through the point of work and the <i>C</i> and <i>N poles</i> as a result of any earths being placed on pole conductors of system.
Earth Switch C	Open Earth Switch C and apply the "Do Not Earth Conductors Notice"	To stop any <i>ACR</i> current flowing through the work area or increased <i>ACR</i> current through insulated bonding cable.
Earth Switch D	Open Earth Switch D and apply the "Do Not Earth Conductors Notice"	To stop any <i>ACR</i> current flowing through the work area or increased <i>ACR</i> current through insulated bonding cable. The closing of this earth switch will create an <i>ACR</i> path.
<i>Earthing restriction zone</i> ER1	No earths to be placed on any equipment within the <i>earthing restriction zone</i> .	During maintenance works it may be necessary to apply an earth to one or more of the conductors. If an earth were also to be placed on the same conductor in region ER1 then <i>ACR</i> current could flow along conductors upon which maintenance is being performed.
<i>Earthing restriction zone</i> ER2	No earths to be placed on any equipment within the <i>earthing restriction zone</i> .	During maintenance works it may be necessary to apply an earth to one or more of the cable conductors. If an earth were also to be placed on the same conductor in region ER2 then <i>ACR</i> current could flow along conductors upon which maintenance is being performed.

Before commencing work in AREA 14 the 25kV power cable sheath and cable joint coverings shall be confirmed to be intact by testing.

CONFIGURATION F CONFIGURATION F – AREA 5

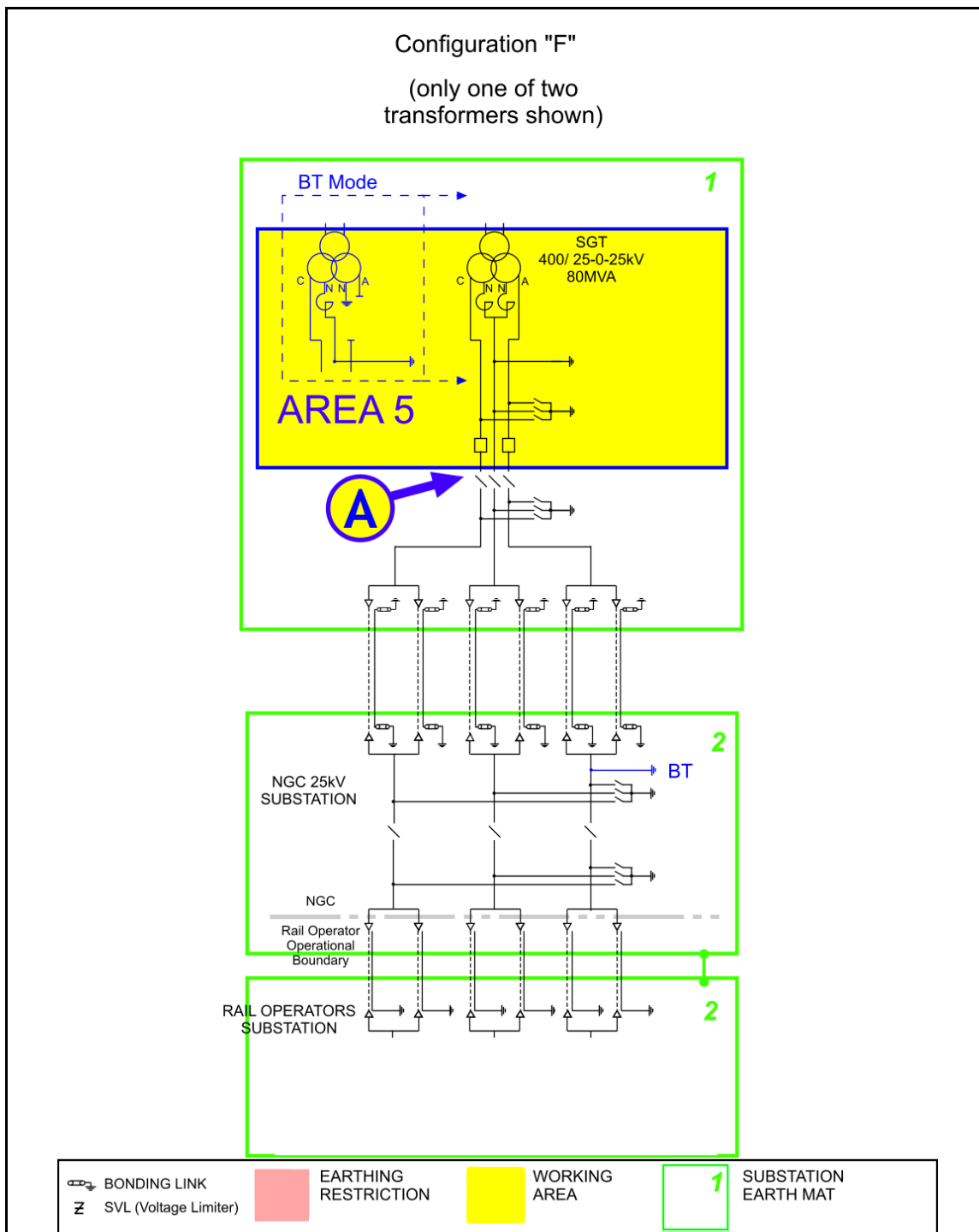

The following table is not a switching sequence. A **Senior Authorised Person** shall include the following tabulated precautions required on **Equipment** as part of a switching, isolating and earthing sequence to eliminate *ACR Current* from the designated working AREA.

AREA 5

Equipment	Precautions Required	Reason
Disconnecter A	Check open, lock and apply the "Do Not Close Notice"	To prevent any <i>ACR Current</i> from finding a return path through the work area.

WARNING!

THE 25KV CABLE SHEATH LINKS SHALL NEVER TO BE REMOVED OR REPLACED WITHOUT A DOUBLE CIRCUIT OUTAGE.

The reason for this is that they solidly bond the Coreys Mill earth mat to the Wymondley earth mat providing an earth return path as the Return Conductor is not earthed at Coreys Mill. As a result there is always the possibility of significant *ACR Currents* flowing through these links.

CONFIGURATION F – AREAS 12A AND 12B

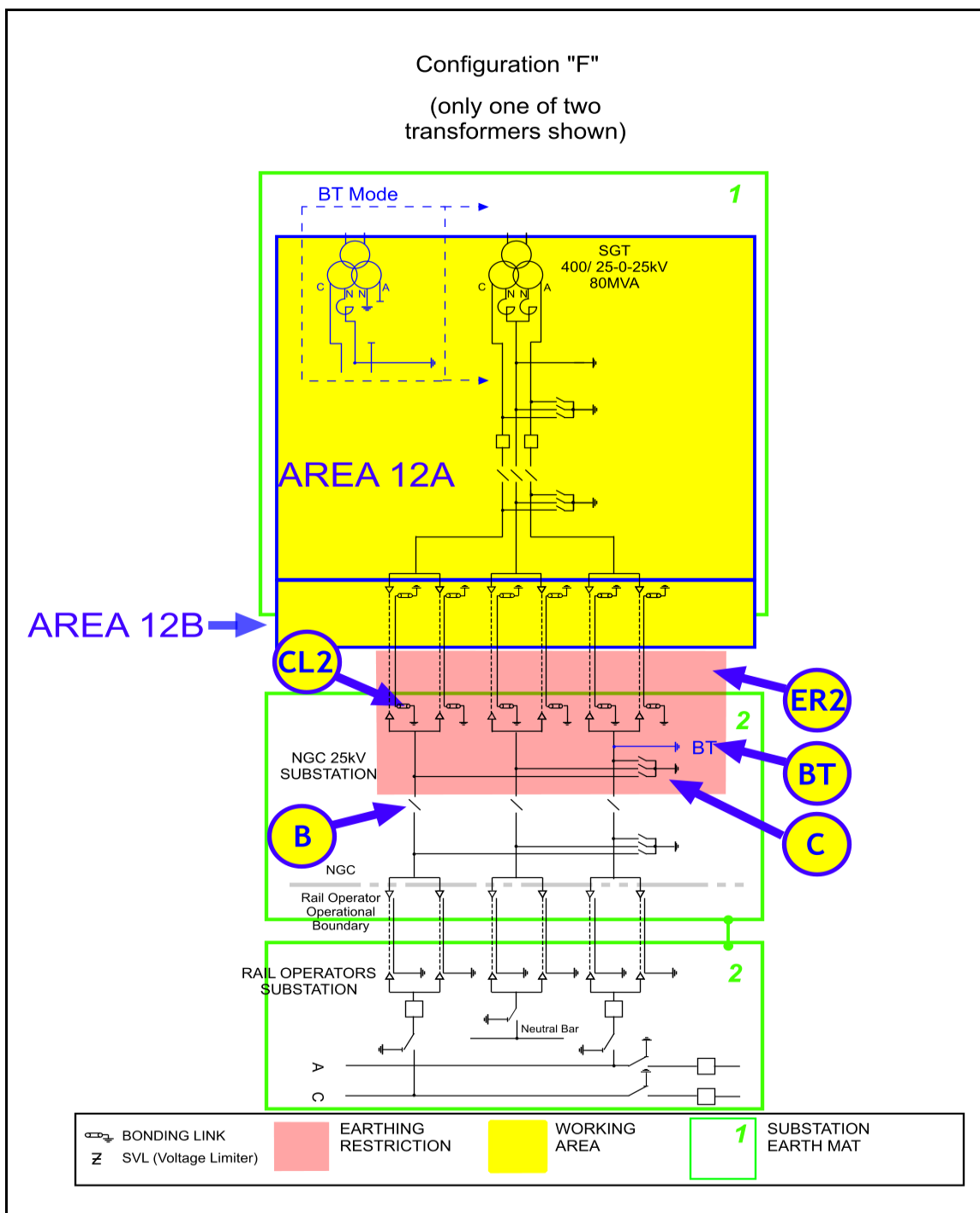

The following table is not a switching sequence. A **Senior Authorised Person** shall include the following tabulated precautions required on **Equipment** as part of a switching, isolating and earthing sequence to eliminate *ACR Current* from the designated working AREA.

AREA 12A

Equipment	Precautions Required	Reason
Disconnecter B	Check, open, lock and apply the "Do Not Close Notice"	Disconnect conductors from 25kV substation and rail operators system to stop <i>ACR Current</i> between earth mats via the pole and <i>Neutral Conductors</i> .
Earth Switch C	Open Earth Switch C and apply the "Do Not Earth Conductors Notice"	This precaution is necessary, as an earth on any of the Poles or <i>Neutral Conductor</i> will create a parallel path through which <i>ACR Current</i> will flow.
Earth restriction region ER2	Do not apply earths on Equipment inside regions ER2.	This precaution is necessary, as an earth on any of the Poles, <i>Neutral Conductor</i> or Cable Sheath will create a parallel path through which <i>ACR Current</i> will flow.
BT conductor earth, BT.	Remove conductor earth, apply the "Do Not Earth Conductors Notice" A Permit will be required for this action.	Action is required to prevent <i>ACR Current</i> flowing along <i>A Pole</i> conductors when an earth is placed on the <i>A Pole</i> conductor in AREA 12A or 12B. Additional precautions may be necessary to avoid the Dangers of induced voltages. This earth must be in place if the circuit is to be energised in permanent <i>BT Mode</i> .

AREA 12B

If works are required on, or that could infringe a **Safety Distance** to, the cables, cable sealing ends or cable sheath connections then the following additional requirement to those for AREA 12A applies.

Cable sheath earth links CL2.	These links need to be removed. WARNING! THIS CAN ONLY BE UNDERTAKEN DURING A DOUBLE CIRCUIT OUTAGE. Remove cable sheath earth and bonding links. Apply the "Do Not Earth Conductors Notice".	WARNING! THE CABLE SHEATH LINKS SHALL NEVER BE REMOVED OR REPLACED WITHOUT A DOUBLE CIRCUIT OUTAGE. The reason for this is that they solidly bond the Coreys Mill earth mat to the Wymondley earth mat providing an earth return path as the Return Conductor is not earthed at Coreys Mill. As a result there is always the possibility of significant <i>ACR Currents</i> flowing through these links. During the double circuit outage a cable sheath test should be carried out to ensure its integrity prior to relying on the removal of the links as a <i>ACR</i> precaution and returning the operational circuit back into service.
-------------------------------	--	---

For guidance on the use of AREA 12B or AREA 13 refer to section 4.3 of this document.

For multiple work locations on cables or their accessories refer to section 8.1 of this document.

CONFIGURATION F – AREA 13

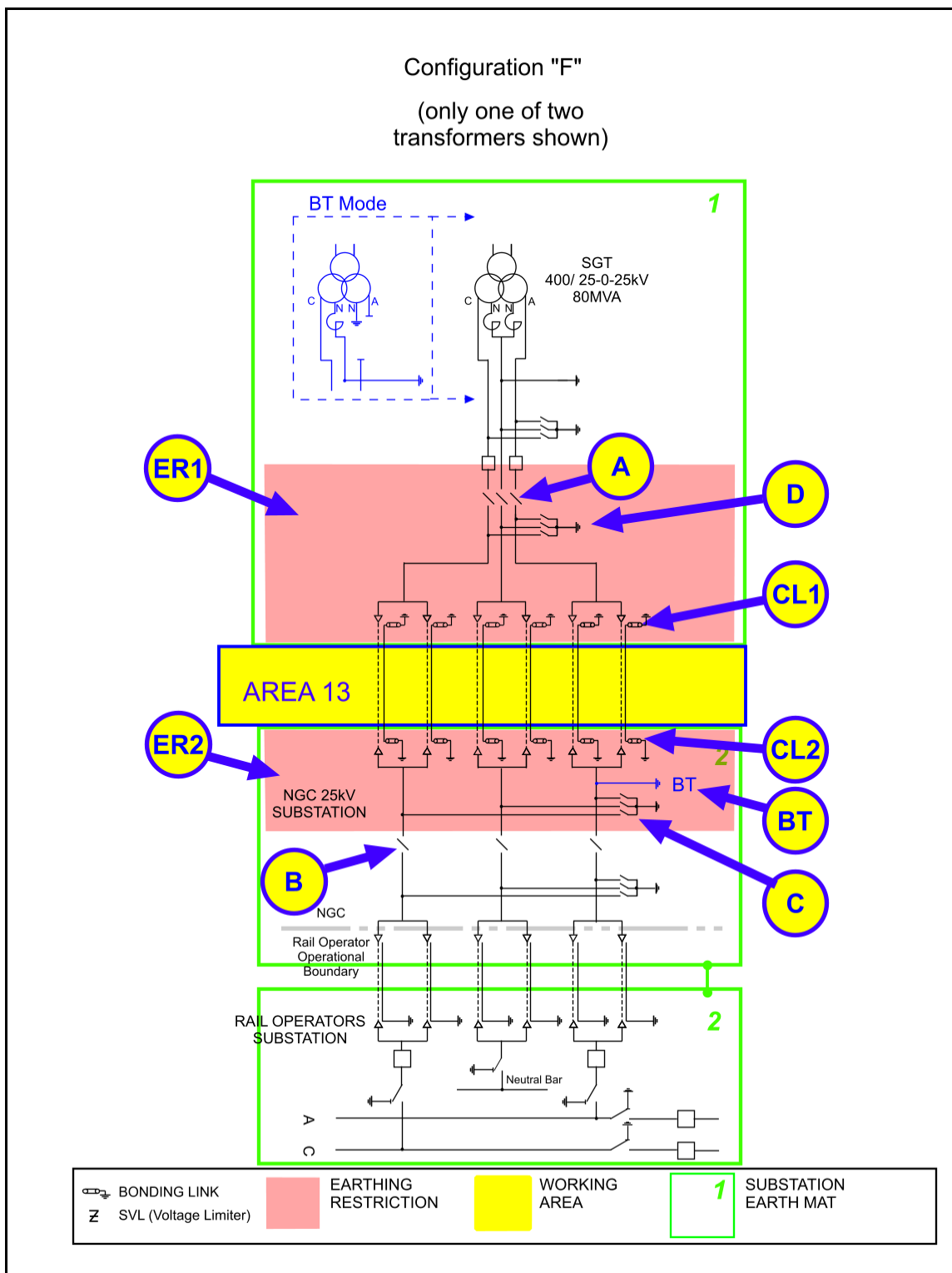

The following table is not a switching sequence. A **Senior Authorised Person** shall include the following tabulated precautions required on **Equipment** as part of a switching, isolating and earthing sequence to eliminate *ACR Current* from the designated working AREA.

AREA 13

Equipment	Precautions Required	Reason
Disconnectors A and B	Check, open, lock and apply the "Do Not Close Notice"	Avoid <i>ACR Current</i> in conductors between the 25kV and 400kV substations from the rail operator's system.
Earth Switches C and D	Open Earth Switches and apply the "Do Not Earth Conductors Notice"	This precaution is necessary to prevent <i>ACR Current</i> flowing along the cable and through the mass of earth when an earth is placed on a cable conductor or sheath in AREA 13.
<i>Earthing restriction zones</i> ER1 and ER2.	Do not apply earths on Equipment inside regions ER1 or ER2.	This precaution is necessary to prevent <i>ACR Current</i> flowing along the cable and through the mass of earth when an earth is placed on a cable conductor or sheath in AREA 13. The placing of an earth in the restricted regions ER1 or ER2 would create an alternative path for <i>ACR Currents</i> .
BT conductor earth, BT.	Remove conductor earth, apply the "Do Not Earth Conductors Notice" A Permit will be required for this action.	Action is required to prevent <i>ACR Current</i> flowing along A Pole conductors when an earth is placed on the A Pole conductor in AREA 13. Additional precautions may be necessary to avoid the Dangers of induced voltages. This earth must be in place if the circuit is to be energised in permanent BT Mode.
Cable sheath earth links CL1 & CL2.	These links need to be removed. WARNING! THIS CAN ONLY BE UNDERTAKEN DURING A DOUBLE CIRCUIT OUTAGE. Remove cable sheath earth and bonding links. Apply the "Do Not Earth Conductors Notice".	WARNING! THE CABLE SHEATH LINKS SHALL NEVER BE REMOVED OR REPLACED WITHOUT A DOUBLE CIRCUIT OUTAGE. The reason for this is that they solidly bond the Coreys Mill earth mat to the Wymondley earth mat providing an earth return path as the Return Conductor is not earthed at Coreys Mill. As a result there is always the possibility of significant <i>ACR Currents</i> flowing through these links. During the double circuit outage a cable sheath test should be carried out to ensure its integrity prior to relying on the removal of the links as a <i>ACR</i> precaution and returning the operational circuit back into service.

For guidance on the use of AREA 12B, AREA 14B or AREA 13 refer to section 4.3 of this document.

For multiple work locations on cables or their accessories refer to section 8.1 of this document.

CONFIGURATION F – AREA 14A AND 14B

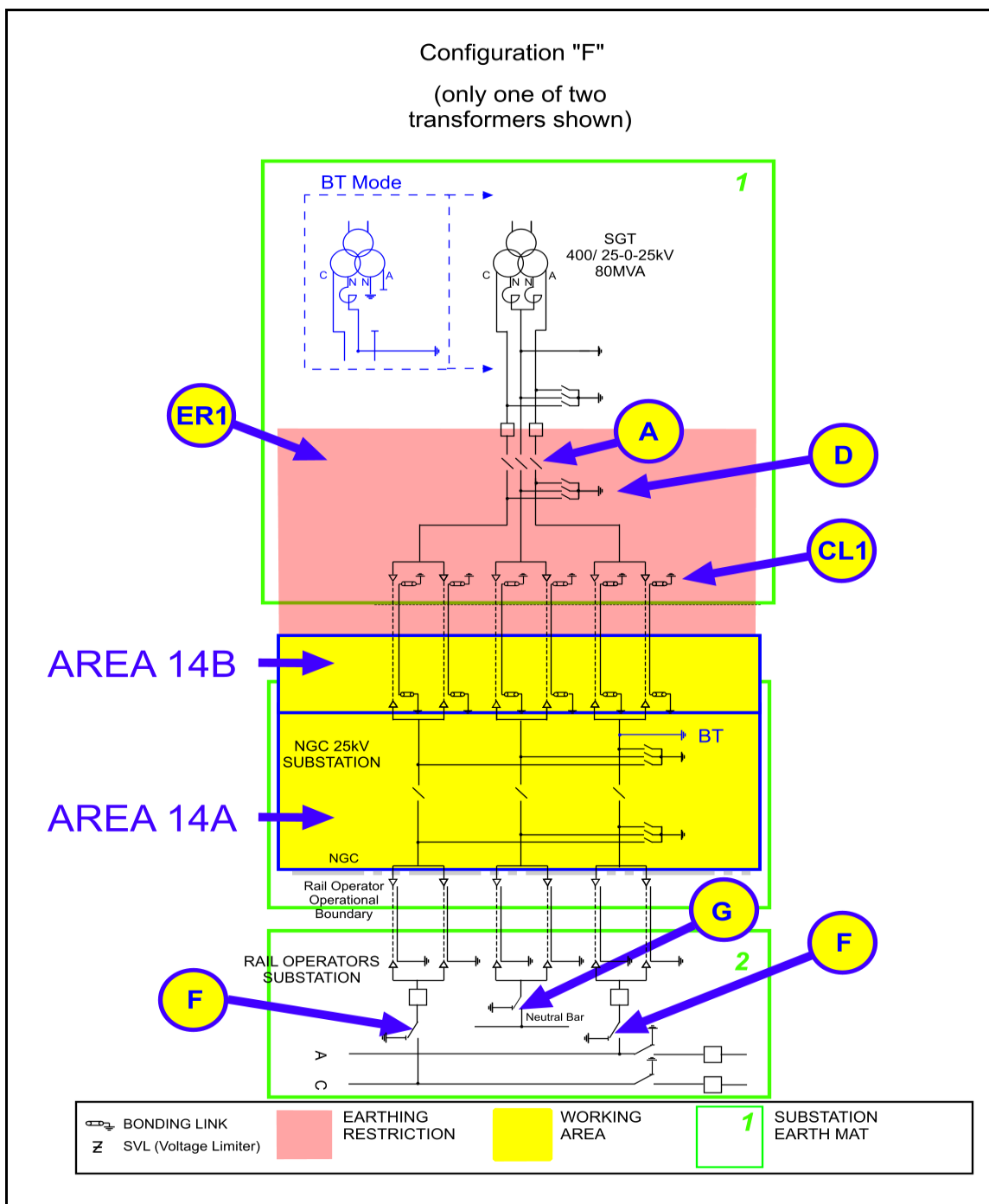

The following table is not a switching sequence. A **Senior Authorised Person** shall include the following tabulated precautions required on **Equipment** as part of a switching, isolating and earthing sequence to eliminate *ACR Current* from the designated working AREA.

AREA 14A

Equipment	Precautions Required	Reason
Disconnecter A	Check, open, lock and apply the "Do Not Close Notice"	Disconnect conductors from 25kV substation and rail operators system and stop <i>ACR Current</i> between earth mats, via the pole and <i>Neutral Conductors</i> , find a return path through the transformer earth.
Earth Switch D	Open Earth Switch D and apply the "Do Not Earth Conductors Notice".	This precaution is necessary to prevent return currents flowing along conductors if an earth is placed on a conductor, which would create a parallel path for <i>ACR Currents</i> .
Disconnecter F	Locked Open	This disconnecter and associated Circuit Breaker needs to be locked open.
Neutral Isolation Device G	Locked Open	This neutral isolation device needs to be locked open.
<i>Earthing restriction zone</i> ER1.	Do not apply earths on Equipment inside region ER1.	This precaution is necessary to prevent return currents flowing along conductors if an earth is placed on a conductor, which would create a parallel path for <i>ACR Currents</i> .

AREA 14B

If works are required on, or that may infringe **Safety Distance** to, the Cables, Cable Sealing Ends or Cable Sheath connections then the following additional requirement to those for AREA 14A applies.

Cable sheath earth links CL1.	<p>These links need to be removed, however.</p> <p>WARNING!</p> <p>THIS CAN ONLY BE UNDERTAKEN DURING A DOUBLE CIRCUIT OUTAGE.</p> <p>Remove cable sheath earth and bonding links. Apply the "Do Not Earth Conductors Notice".</p>	<p>WARNING!</p> <p>THE CABLE SHEATH LINKS SHALL NEVER BE REMOVED OR REPLACED WITHOUT A DOUBLE CIRCUIT OUTAGE.</p> <p>The reason for this is that they solidly bond the Coreys Mill earth mat to the Wymondley earth mat providing an earth return path as the Return Conductor is not earthed at Coreys Mill. As a result there is always the possibility of significant <i>ACR Currents</i> flowing through these links.</p> <p>During the double circuit outage a cable sheath test should be carried out to ensure its integrity prior to relying on the removal of the links as a <i>ACR</i> precaution and returning the operational circuit back into service.</p>
-------------------------------	--	--

For guidance on the use of AREA 13 or AREA 14B refer to section 4.3 of this document.

For multiple work locations on cables or their accessories refer to section 8.1 of this document.

CONFIGURATION G

CONFIGURATION G – AREA 1

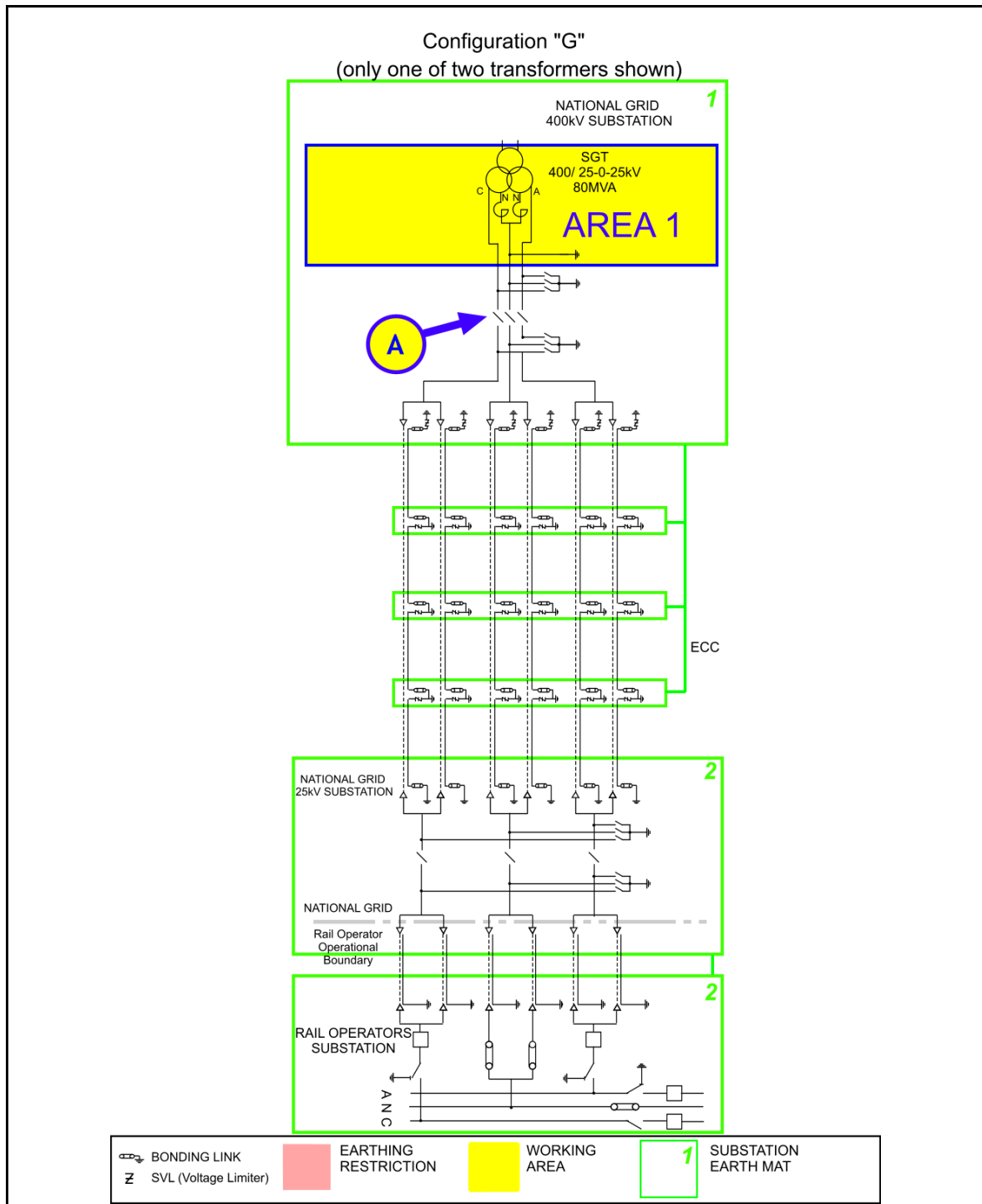

The following table is not a switching sequence. A **Senior Authorised Person** shall include the following tabulated precautions required on **Equipment** as part of a switching, isolating and earthing sequence to eliminate *ACR Current* from the designated working AREA.

AREA 1

Equipment	Precautions Required	Reason
Disconnecter A	Check open, lock and apply the "Do Not Close Notice"	To prevent any <i>ACR Current</i> from finding a return path through the work area.

CONFIGURATION G – AREA 2A AND AREA 2B

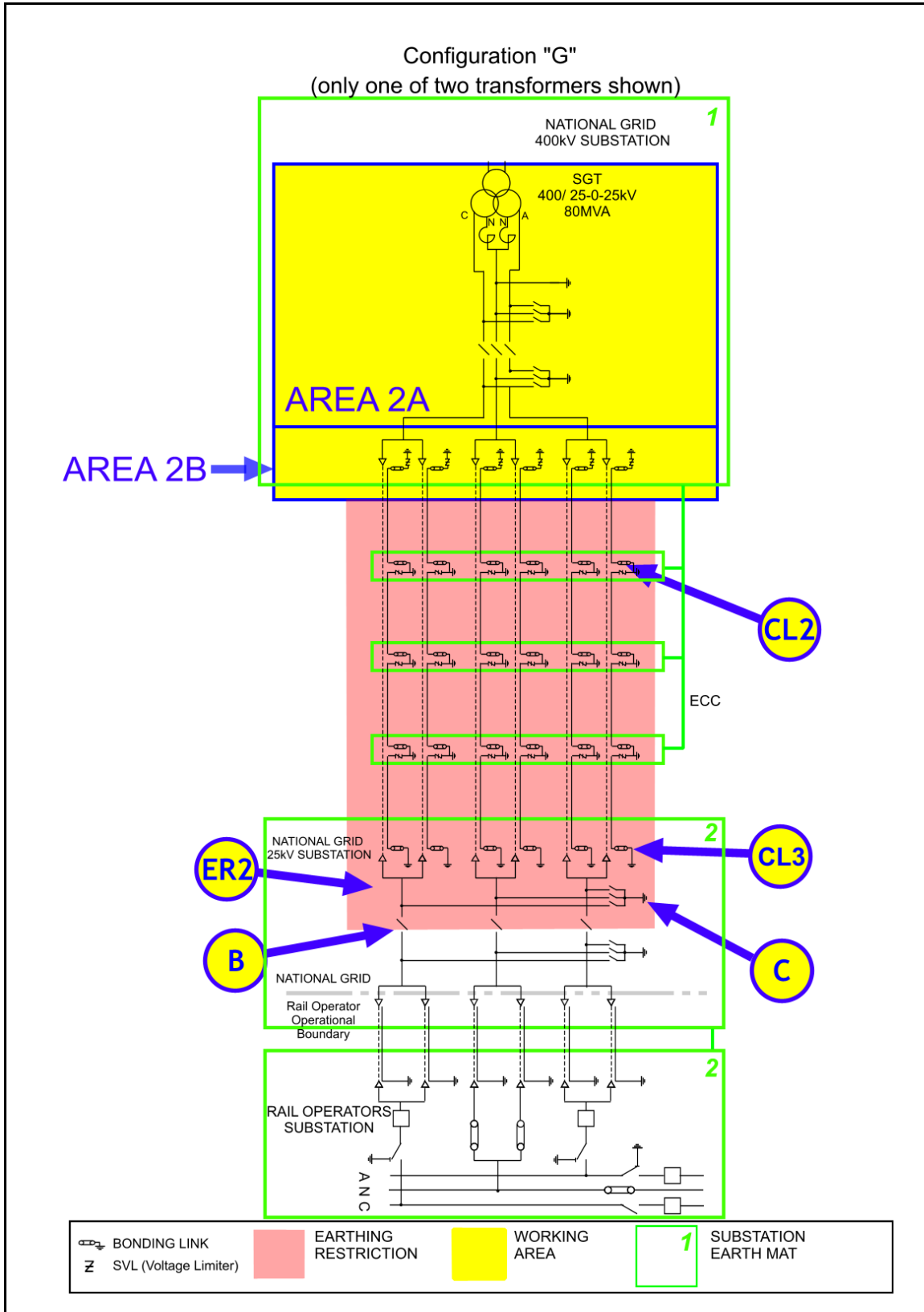

The following table is not a switching sequence. A **Senior Authorised Person** shall include the following tabulated precautions required on **Equipment** as part of a switching, isolating and earthing sequence to eliminate *ACR Current* from the designated working AREA.

AREA 2A

Equipment	Precautions Required	Reason
Disconnectors B	Check open, lock and apply the "Do Not Close Notice"	Disconnect conductors from 25kV substation and rail operators System to stop <i>ACR Current</i> between earth mats via the pole and <i>Neutral Conductors</i> .
Earth Switch C	Open Earth Switch C and apply the "Do Not Earth Conductors Notice"	This precaution is necessary, as an earth on any of the Poles or <i>Neutral Conductor</i> will create a parallel path through which <i>ACR Current</i> will flow.
Earth restriction region ER2	Do not apply earths on Equipment inside regions ER2.	This precaution is necessary, as an earth on any of the Poles, <i>Neutral Conductor</i> or Cable Sheath will create a parallel path through which <i>ACR Current</i> will flow.

AREA 2B

If works are required on, or that could infringe a **Safety Distance** to, the cables, cable sealing ends or cable sheath connections then the following additional requirement to those for AREA 2A applies.

Cable sheath bonding links, CL3.	Remove the cable sheath bonding link. Apply the "Do Not Earth Conductors Notice".	These cable sheath bonding links are removed in case the SVLs on the same cable section are not operating correctly. Removal of the cable sheath bonding links from all cables will prevent <i>ACR Current</i> flowing along the cable sheaths from the 25kV substation earth mat.
Cable sheath bonding links CL2.	Remove the cable sheath earth link in accordance with the principles of NSI 5. Apply the "Do Not Earth Conductors Notice".	These cable sheath bonding links are removed in case the SVLs are not operating correctly. Removal of the cable sheath bonding links from all cables will prevent <i>ACR Current</i> flowing between the earth mats along the cable sheaths.

For guidance on the use of AREA 2B or AREA 3A refer to section 4.3 of this document.

For multiple work locations on cables or their accessories refer to section 8.1 of this document.

CONFIGURATION G – AREA 3A

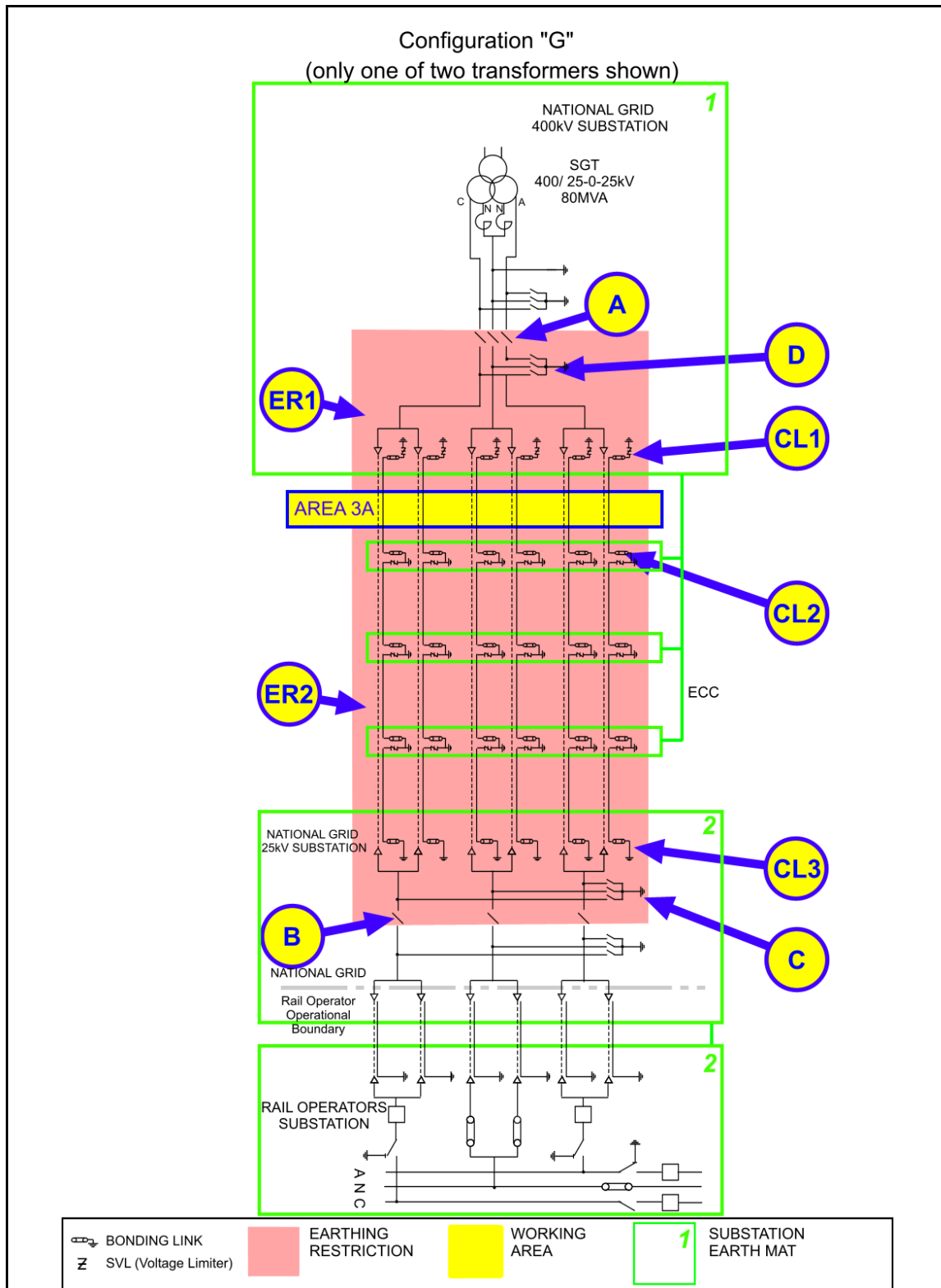

The following table is not a switching sequence. A **Senior Authorised Person** shall include the following tabulated precautions required on **Equipment** as part of a switching, isolating and earthing sequence to eliminate *ACR Current* from the designated working AREA.

AREA 3A

Equipment	Precautions Required	Reason
Disconnectors A and B	Check open, lock and apply the "Do Not Close Notice"	Avoid <i>ACR Current</i> in conductors between the 25kV and 400kV substations from the rail operator's System .
Earth Switches C and D	Open Earth Switches and apply the "Do not Earth Conductors Notice"	This precaution is necessary to prevent <i>ACR Current</i> flowing along the cable and through the mass of earth when an earth is placed on a cable conductor or sheath in the work area.
<i>Earthing restriction zones</i> ER1 and ER2.	Do not apply earths on Equipment inside regions ER1 or ER2.	This precaution is necessary to prevent <i>ACR Current</i> flowing along the cable and through the mass of earth when an earth is placed on a cable conductor or sheath in the work area. The placing of an earth in the restricted region(s) would create an alternative path for <i>ACR Current(s)</i> .
Cable sheath bonding links, CL3.	Remove the cable sheath bonding link. Apply the "Do Not Earth Conductors Notice".	These cable sheath bonding links are removed in case the SVLs on the same cable section are not operating correctly. Removal of the cable sheath bonding links from all cables will prevent <i>ACR Current</i> flowing along the cable sheaths from the 25kV substation earth mat.
Cable sheath bonding links CL2.	Remove the cable sheath bonding links in accordance with the principles of NSI 5. Apply the "Do Not Earth Conductors Notice".	These cable earth bonding links are removed in case the SVLs at CL1 are not operating correctly. Removal of the cable sheath bonding links from all cables will prevent <i>ACR Current</i> flowing between the earth mats via the cable sheaths. The cable bonding links "CL2" at the solidly bonded position shall be removed prior to removing the links "CL1" at an SVL position. This will avoid <i>ACR Current(s)</i> flowing during the application of Earthing Devices.
Cable sheath SVL links, CL1.	Remove cable sheath earth and bonding links.). Apply the "Do not Earth Conductors Notice".	These links are to be removed in case the SVLs are not operating correctly. Removal of the links from all cables will prevent <i>ACR Current</i> flowing between the earth mats along the cable sheaths.

For guidance on the use of AREA 2B, AREA 15A or AREA 3A refer section 4.3 of this document.

For multiple work locations on cables or their accessories refer to section 8.1 of this document.

CONFIGURATION G – AREA 3B

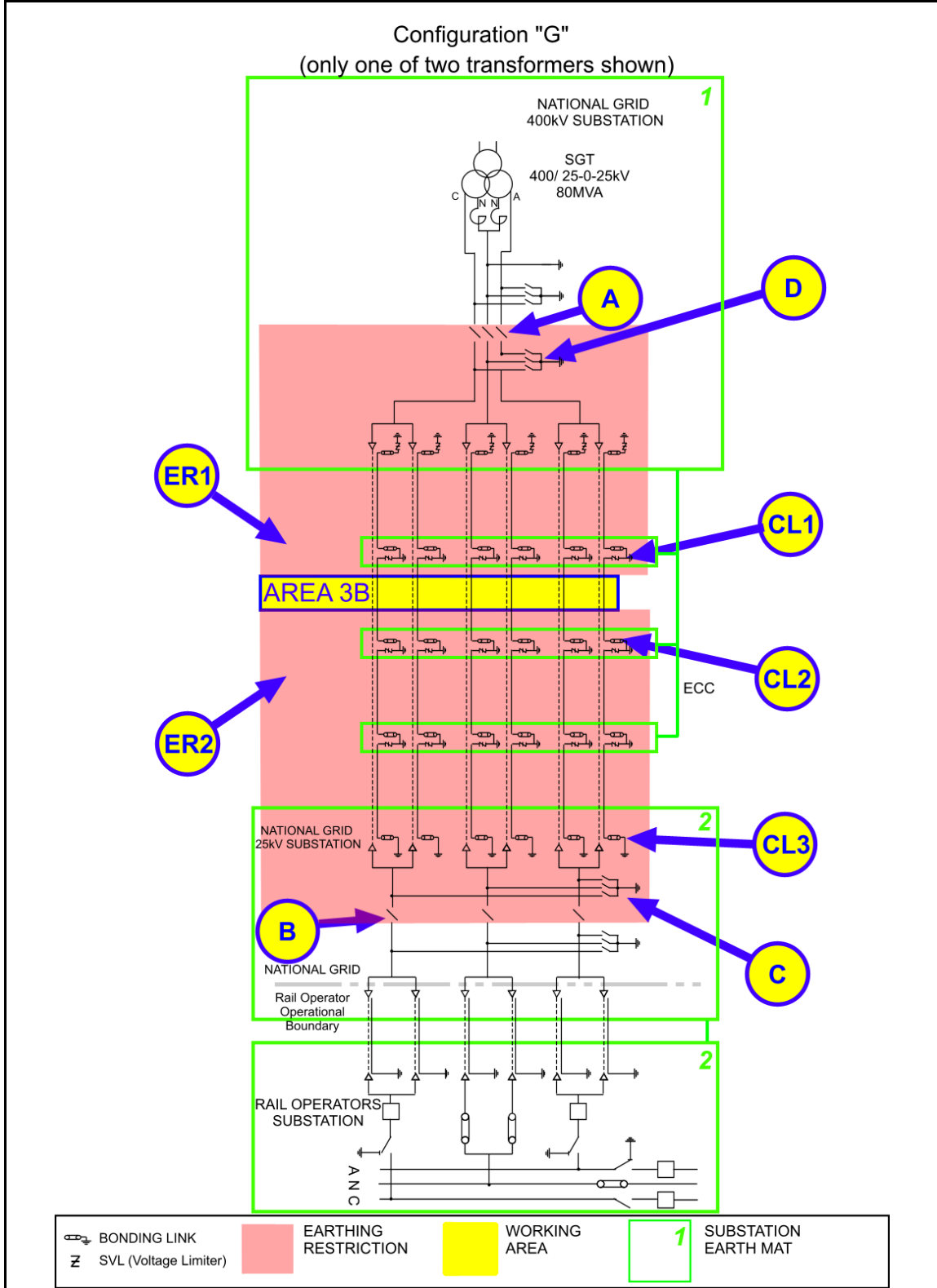

The following table is not a switching sequence. A **Senior Authorised Person** shall include the following tabulated precautions required on **Equipment** as part of a switching, isolating and earthing sequence to eliminate *ACR Current* from the designated working AREA.

AREA 3B

Equipment	Precautions Required	Reason
Disconnectors A and B	Check open, lock and apply the "Do Not Close Notice"	Avoid <i>ACR Current</i> in conductors between the 25kV and 400kV substations from the rail operator's System .
Earth Switches C and D	Open Earth Switches and apply the "Do not Earth Conductors Notice"	This precaution is necessary to prevent <i>ACR Current</i> flowing along the cable and through the mass of earth when an earth is placed on a cable conductor or sheath in the work area.
<i>Earthing restriction zones</i> ER1 and ER2.	Do not apply earths on Equipment inside regions ER1 or ER2.	This precaution is necessary to prevent <i>ACR Current</i> flowing along the cable and through the mass of earth when an earth is placed on a cable conductor or sheath in the work area. The placing of an earth in the restricted region(s) would create an alternative path for <i>ACR Current(s)</i> .
Cable sheath bonding links, CL3.	Remove the cable sheath bonding link. Apply the "Do Not Earth Conductors Notice".	These cable sheath bonding links are removed in case the SVLs on the same cable section are not operating correctly. Removal of the cable sheath bonding links from all cables will prevent <i>ACR Current</i> flowing along the cable sheaths from the 25kV substation earth mat.
Cable sheath bonding links, CL2.	Remove the sheath links in accordance with the principles of NSI 5. Apply the "Do Not Earth Conductors Notice".	These links are removed in case the SVLs at CL1 are not operating correctly. Removal of the SVLs from all cables will prevent <i>ACR Current</i> flowing between the earth mats along the cable sheaths. The cable bonding links "CL2" at the solidly bonded position shall be removed prior to removing the links "CL1" at an SVL position. This will avoid <i>ACR Current(s)</i> flowing during the application of Earthing Devices.
Cable SVLs CL1.	Remove the sheath voltage limiter in accordance with the principles of NSI 5. Apply the "Do Not Earth Conductors Notice".	These SVLs are removed in case the SVLs are not operating correctly. Removal of the SVLs from all cables will prevent <i>ACR Current</i> flowing between the earth mats along the cable sheaths.

For guidance on the use of AREA 15A, AREA 15B or AREA refer to section 4.3 of this document.

For multiple work locations on cables or their accessories refer to section 8.1 of this document.

CONFIGURATION G – AREA 3C

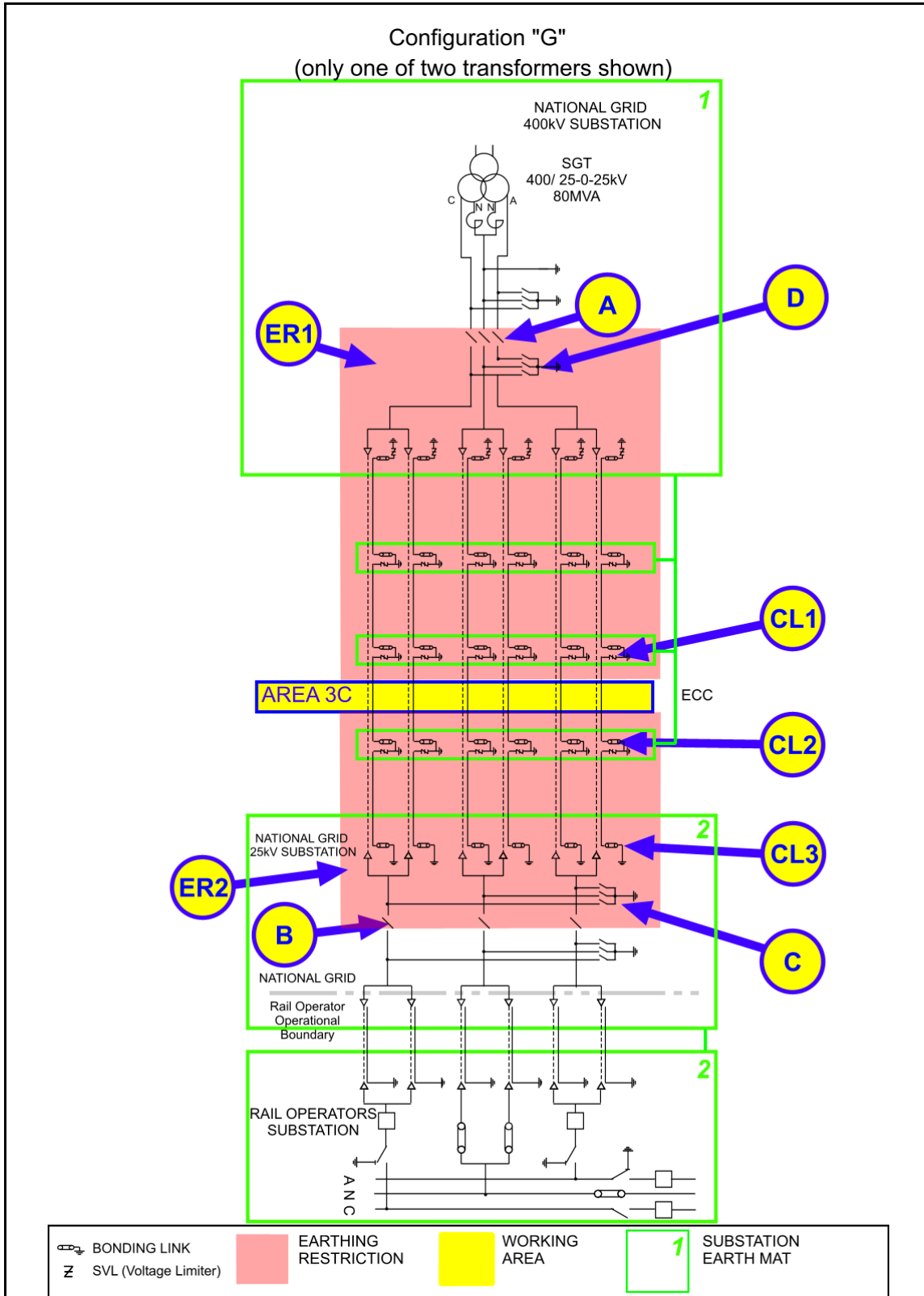

The following table is not a switching sequence. A **Senior Authorised Person** shall include the following tabulated precautions required on **Equipment** as part of a switching, isolating and earthing sequence to eliminate *ACR Current* from the designated working AREA.

AREA 3C

Equipment	Precautions Required	Reason
Disconnectors A and B	Check open, lock and apply the "Do Not Close Notice"	Avoid <i>ACR Current</i> in conductors between the 25kV and 400kV substations from the rail operator's System .
Earth Switches C and D	Open Earth Switches and apply the "Do not Earth Conductors Notice"	This precaution is necessary to prevent <i>ACR Current</i> flowing along the cable and through the mass of earth when an earth is placed on a cable conductor or sheath in the work area.
<i>Earthing restriction zones</i> ER1 and ER2.	Do not apply earths on Equipment inside regions ER1 or ER2.	This precaution is necessary to prevent <i>ACR Current</i> flowing along the cable and through the mass of earth when an earth is placed on a cable conductor or sheath in the work area. The placing of an earth in the restricted region(s) would create an alternative path for <i>ACR Current(s)</i> .
Cable sheath bonding links, CL3.	Remove the cable sheath bonding link. Apply the "Do Not Earth Conductors Notice".	These cable sheath bonding links are removed in case the SVLs on the same cable section are not operating correctly. Removal of the cable sheath bonding links from all cables will prevent <i>ACR Current</i> flowing along the cable sheaths from the 25kV substation earth mat.
Cable sheath bonding links CL2.	Remove the sheath links in accordance with the principles of NSI 5. Apply the "Do Not Earth Conductors Notice".	These links are removed in case the SVLs are not operating correctly at CL1. Removal of the SVLs from all cables will prevent <i>ACR Current</i> flowing between the earth mats along the cable sheaths. The cable bonding links "CL2" at the solidly bonded position shall be removed prior to removing the links "CL1" at an SVL position. This will avoid <i>ACR Current(s)</i> flowing during the application of Earthing Devices.
Cable SVLs CL1.	Remove the sheath voltage limiters in accordance with the principles of NSI 5. Apply the "Do Not Earth Conductors Notice".	These SVLs are removed in case the SVLs are not operating correctly. Removal of the SVLs from all cables will prevent <i>ACR Current</i> flowing between the earth mats along the cable sheaths.

For guidance on the use of AREA 15B, AREA 15D or AREA 3C refer to section 4.3 of this document.

For multiple work locations on cables or their accessories refer to section 8.1 of this document.

CONFIGURATION G – AREA 3D

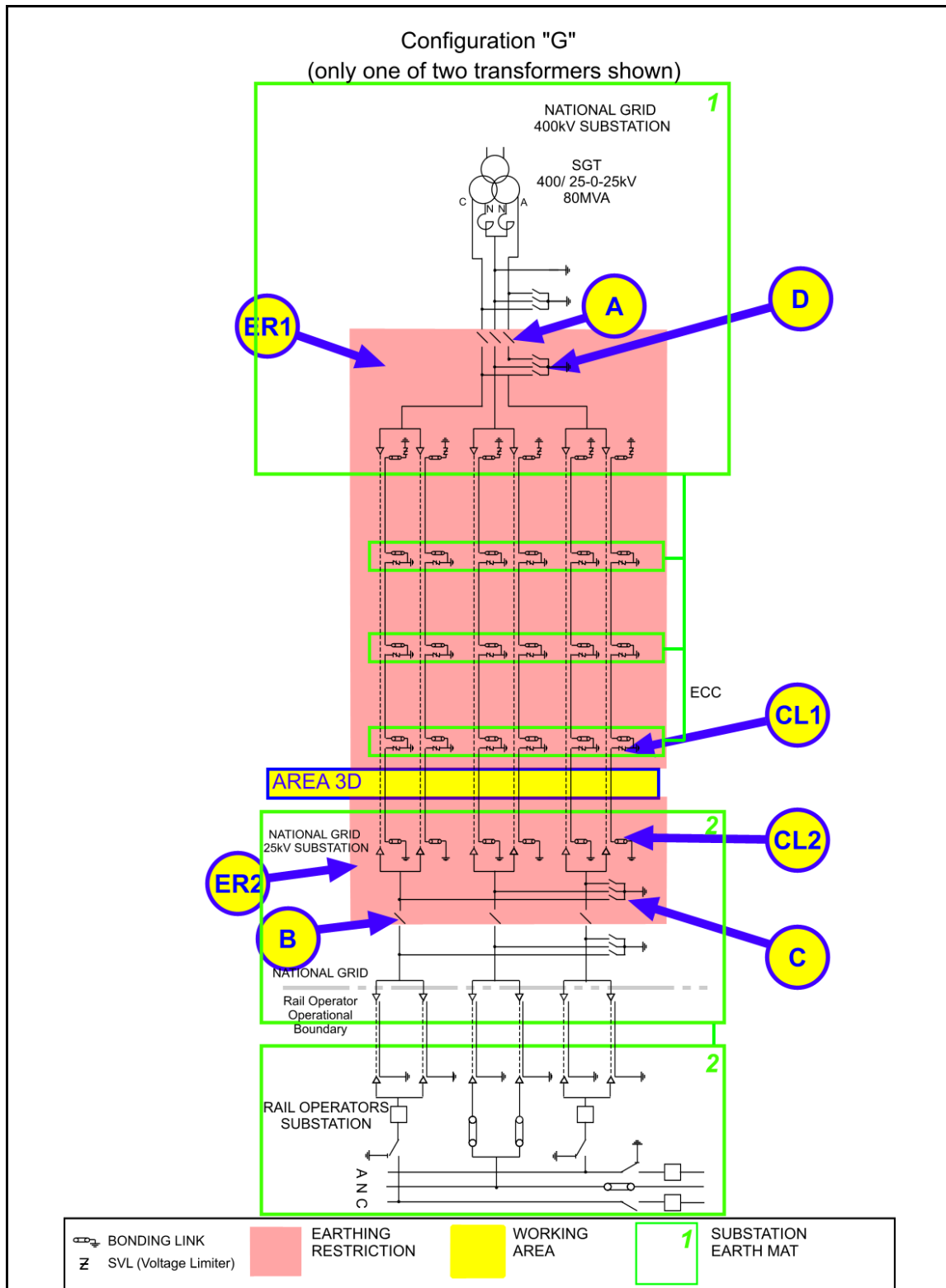

The following table is not a switching sequence. A **Senior Authorised Person** shall include the following tabulated precautions required on **Equipment** as part of a switching, isolating and earthing sequence to eliminate *ACR Current* from the designated working AREA.

AREA 3D

Equipment	Precautions Required	Reason
Disconnectors A and B	Check open, lock and apply the "Do Not Close Notice"	Avoid <i>ACR Current</i> in conductors between the 25kV and 400kV substations from the rail operator's System .
Earth Switches C and D	Open Earth Switches and apply the "Do not Earth Conductors Notice"	This precaution is necessary to prevent <i>ACR Current</i> flowing along the cable and through the mass of earth when an earth is placed on a cable conductor or sheath in the work area.
<i>Earthing restriction zones</i> ER1 and ER2.	Do not apply earths on Equipment inside regions ER1 or ER2.	This precaution is necessary to prevent <i>ACR Current</i> flowing along the cable and through the mass of earth when an earth is placed on a cable conductor or sheath in the work area. The placing of an earth in the restricted region(s) would create an alternative path for <i>ACR Current(s)</i> .
Cable sheath bonding links, CL2.	Remove cable sheath earth and bonding links.). Apply the "Do not Earth Conductors Notice".	These links are to be removed in case the SVLs at CL1 are not operating correctly. Removal of the links from all cables will prevent <i>ACR Current</i> flowing between the earth mats along the cable sheaths. The cable bonding links "CL2" at the solidly bonded position shall be removed prior to removing the links "CL1" at an SVL position. This will avoid <i>ACR Current(s)</i> flowing during the application of Earthing Devices.
Cable SVLs, CL1.	Remove the sheath voltage limiter in accordance with the principles of NSI 5. Apply the "Do Not Earth Conductors Notice".	These SVLs are removed in case the SVLs are not operating correctly. Removal of the SVLs from all cables will prevent <i>ACR Current</i> flowing between the earth mats along the cable sheaths.

For guidance on the use of AREA 15D, AREA 16B or AREA 3D refer to section 4.3 of this document.

For multiple work locations on cables or their accessories refer to section 8.1 of this document.

CONFIGURATION G – AREA 15A

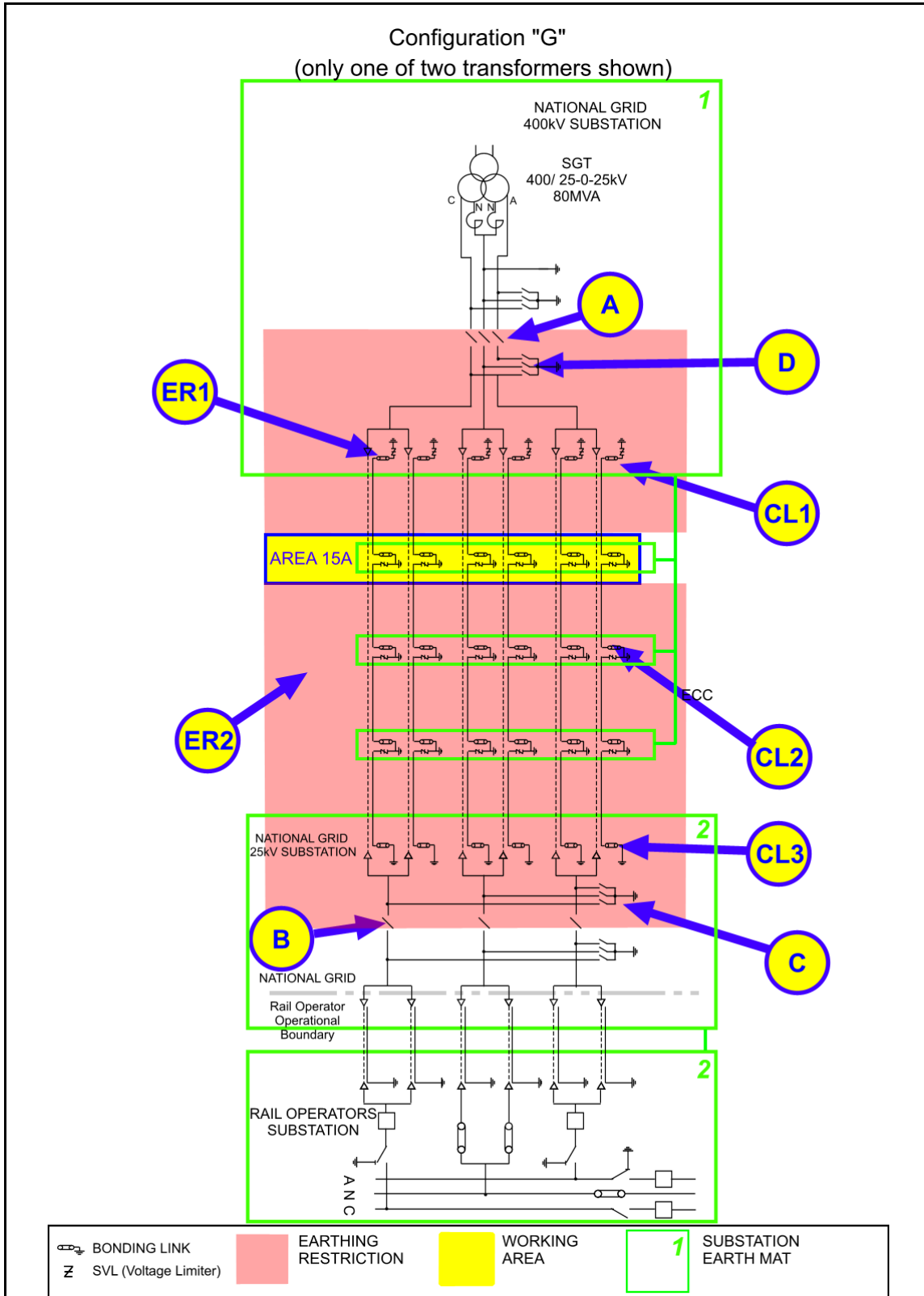

The following table is not a switching sequence. A **Senior Authorised Person** shall include the following tabulated precautions required on **Equipment** as part of a switching, isolating and earthing sequence to eliminate *ACR Current* from the designated working AREA.

AREA 15A

Equipment	Precautions Required	Reason
Disconnectors A and B	Check open, lock and apply the "Do Not Close Notice"	Avoid <i>ACR Current</i> in conductors between the 25kV and 400kV substations from the rail operator's System .
Earth Switches C and D	Open Earth Switches and apply the "Do not Earth Conductors Notice"	This precaution is necessary to prevent <i>ACR Current</i> flowing along the cable and through the mass of earth when an earth is placed on a cable conductor or sheath in the work area.
<i>Earthing restriction zones</i> ER1 and ER2.	Do not apply earths on Equipment inside regions ER1 or ER2.	This precaution is necessary to prevent <i>ACR Current</i> flowing along the cable and through the mass of earth when an earth is placed on a cable conductor or sheath in the work area. The placing of an earth in the restricted region(s) would create an alternative path for <i>ACR Current(s)</i> .
Cable sheath bonding links, CL3.	Remove cable sheath earth and bonding. Apply the "Do not Earth Conductors Notice".	These cable sheath bonding links are removed in case the SVLs are not operating correctly. Removal of the cable sheath bonding links from all cables will prevent <i>ACR Current</i> flowing along the cable sheaths from the 25kV substation earth mat.
Cable sheath bonding links CL2.	Remove the cable sheath bonding links in accordance with the principles of NSI 5. Apply the "Do Not Earth Conductors Notice".	These cable sheath bonding links are removed in case the SVLs at CL1 are not operating correctly. Removal of the cable sheath bonding links from all cables will prevent <i>ACR Current</i> flowing between the earth mats along the cable sheaths. The cable bonding links "CL2" at the solidly bonded position shall be removed prior to removing the links "CL1" at an SVL position. This will avoid <i>ACR Current(s)</i> flowing during the application of Earthing Devices.
Cable sheath SVL links CL1.	Remove cable sheath earth and bonding links. Apply the "Do not Earth Conductors Notice".	These links are to be removed in case the SVLs are not operating correctly. Removal of the links from all cables will prevent <i>ACR Current</i> flowing between the earth mats along the cable sheaths.

For guidance on the use of AREA 15A, AREA 3A or AREA 3B refer to section 4.3 of this document.

For multiple work locations on cables or their accessories refer to section 8.1 of this document.

CONFIGURATION G – AREA 15B

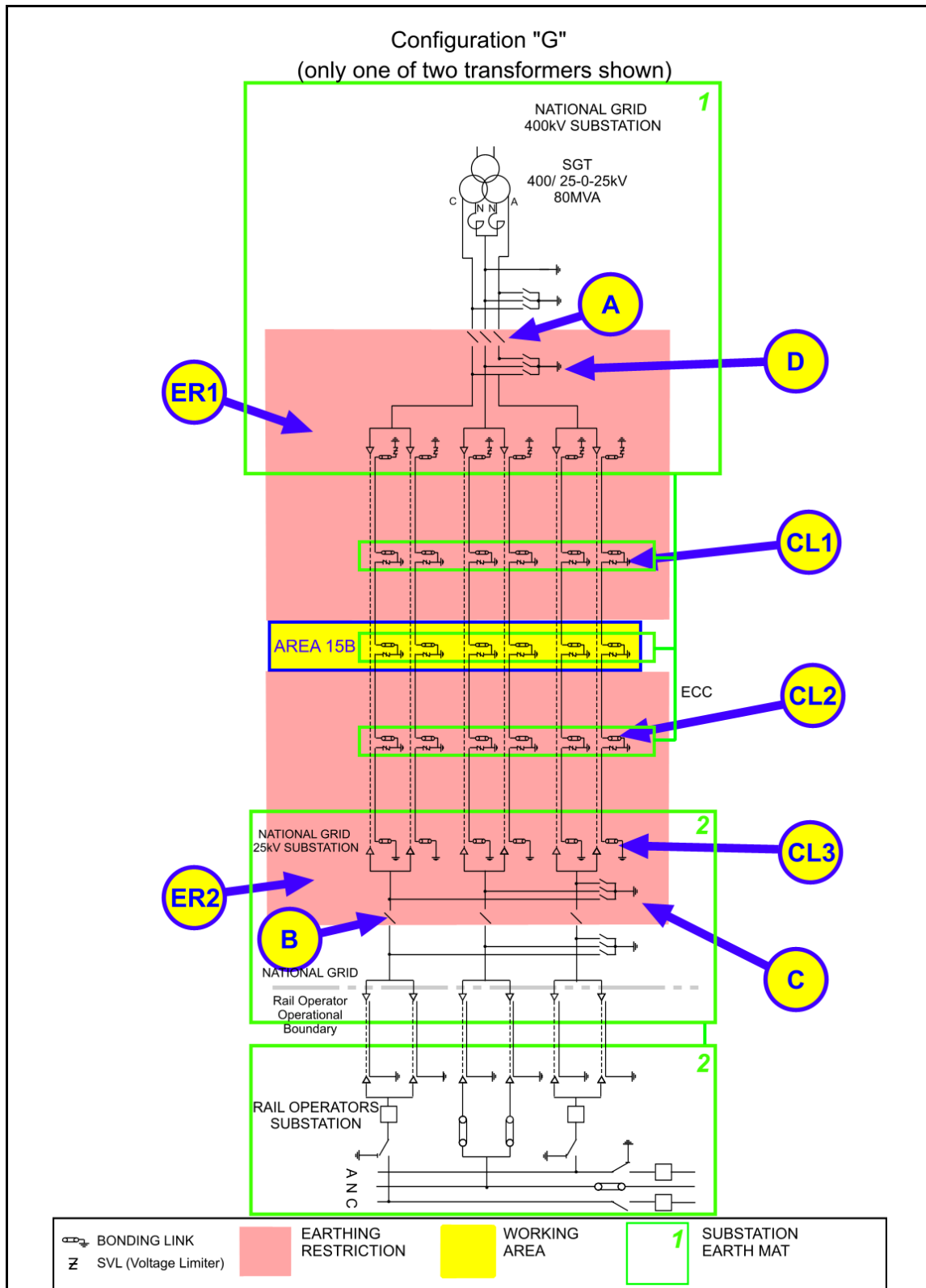

The following table is not a switching sequence. A **Senior Authorised Person** shall include the following tabulated precautions required on **Equipment** as part of a switching, isolating and earthing sequence to eliminate *ACR Current* from the designated working AREA.

AREA 15B

Equipment	Precautions Required	Reason
Disconnectors A and B	Check open, lock and apply the "Do Not Close Notice"	Avoid <i>ACR Current</i> in conductors between the 25kV and 400kV substations from the rail operator's System .
Earth Switches C and D	Open Earth Switches and apply the "Do not Earth Conductors Notice"	This precaution is necessary to prevent <i>ACR Current</i> flowing along the cable and through the mass of earth when an earth is placed on a cable conductor or sheath in the work area.
<i>Earthing restriction zones</i> ER1 and ER2.	Do not apply earths on Equipment inside regions ER1 or ER2.	This precaution is necessary to prevent <i>ACR Current</i> flowing along the cable and through the mass of earth when an earth is placed on a cable conductor or sheath in the work area. The placing of an earth in the restricted region(s) would create an alternative path for <i>ACR Current(s)</i> .
Cable sheath bonding links, CL3.	Remove the cable sheath bonding link. Apply the "Do Not Earth Conductors Notice".	These cable sheath bonding links are removed in case the SVLs on the same cable section are not operating correctly. Removal of the cable sheath bonding links from all cables will prevent <i>ACR Current</i> flowing along the cable sheaths from the 25kV substation earth mat.
Cable sheath bonding links, CL2.	Remove the sheath links in accordance with the principles of NSI 5. Apply the "Do Not Earth Conductors Notice".	These links are removed in case the SVLs at CL1 are not operating correctly. Removal of the SVLs from all cables will prevent <i>ACR Current</i> flowing between the earth mats along the cable sheaths. The cable bonding links "CL2" at the solidly bonded position shall be removed prior to removing the links "CL1" at an SVL position. This will avoid <i>ACR Current(s)</i> flowing during the application of Earthing Devices.
Cable SVLs CL1.	Remove the sheath voltage limiter in accordance with the principles of NSI 5. Apply the "Do Not Earth Conductors Notice".	These SVLs are removed in case the SVLs are not operating correctly. Removal of the SVLs from all cables will prevent <i>ACR Current</i> flowing between the earth mats along the cable sheaths.

For guidance on the use of AREA 15B, AREA 3B or AREA 3C refer to section 4.3 of this document.

For multiple work locations on cables or their accessories refer to section 8.1 of this document.

CONFIGURATION G – AREA 15C

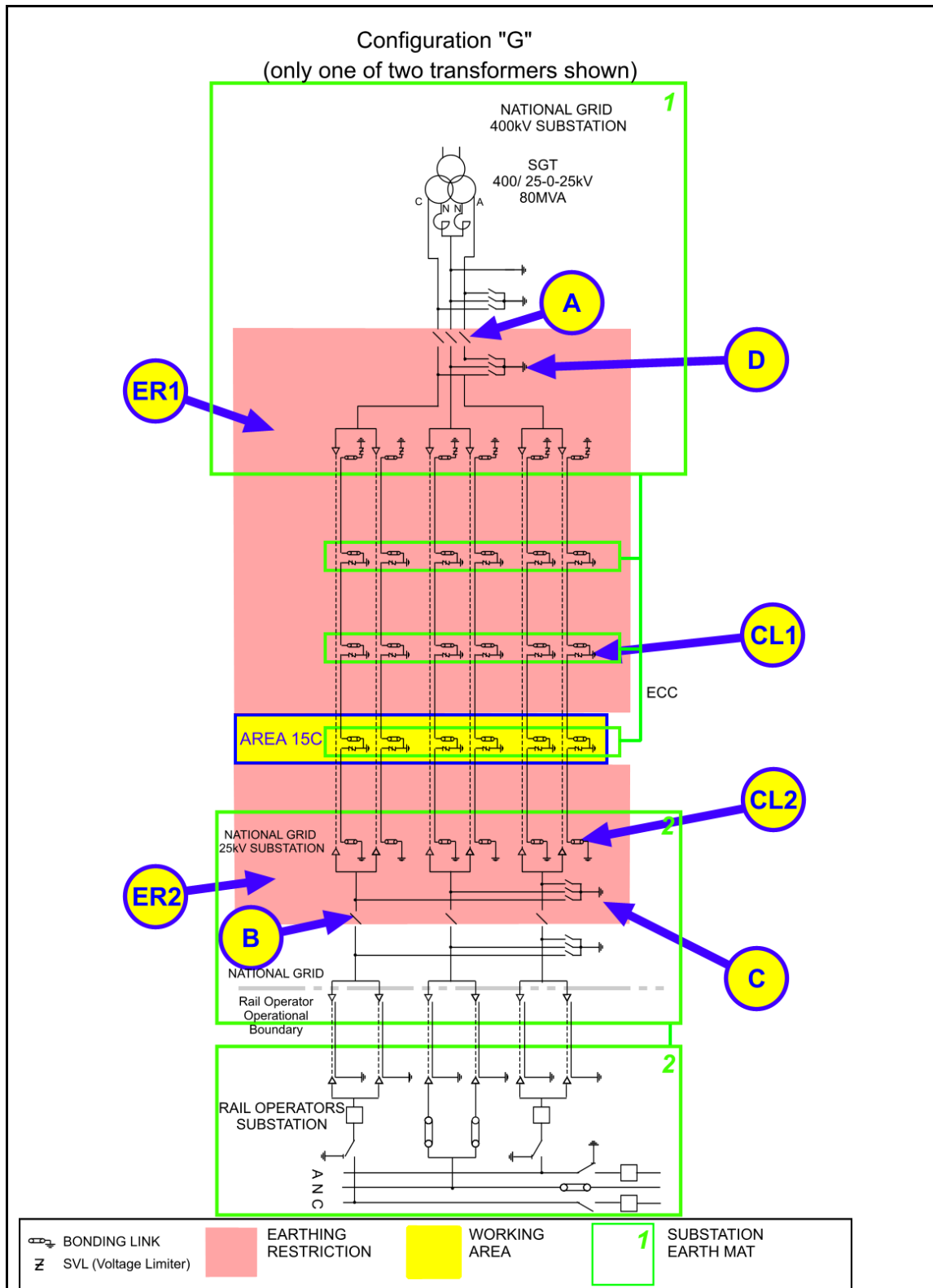

The following table is not a switching sequence. A **Senior Authorised Person** shall include the following tabulated precautions required on **Equipment** as part of a switching, isolating and earthing sequence to eliminate *ACR Current* from the designated working AREA.

AREA 15C

Equipment	Precautions Required	Reason
Disconnectors A and B	Check open, lock and apply the "Do Not Close Notice"	Avoid <i>ACR Current</i> in conductors between the 25kV and 400kV substations from the rail operator's System .
Earth Switches C and D	Open Earth Switches and apply the "Do not Earth Conductors Notice"	This precaution is necessary to prevent <i>ACR Current</i> flowing along the cable and through the mass of earth when an earth is placed on a cable conductor or sheath in the work area.
<i>Earthing restriction zones</i> ER1 and ER2.	Do not apply earths on Equipment inside regions ER1 or ER2.	This precaution is necessary to prevent <i>ACR Current</i> flowing along the cable and through the mass of earth when an earth is placed on a cable conductor or sheath in the work area. The placing of an earth in the restricted region(s) would create an alternative path for <i>ACR Current(s)</i> .
Cable sheath bonding links, CL2.	Remove cable sheath earth and bonding links. Apply the "Do not Earth Conductors Notice".	These links are to be removed in case the SVLs are not operating correctly. Removal of the links from all cables will prevent <i>ACR Current</i> flowing between the earth mats along the cable sheaths. The cable bonding links "CL2" at the solidly bonded position shall be removed prior to removing the links "CL1" at an SVL position. This will avoid <i>ACR Current(s)</i> flowing during the application of Earthing Devices.
Cable SVLs at, CL1.	Remove the sheath voltage limiter in accordance with the principles of NSI 5. Apply the "Do Not Earth Conductors Notice".	These SVLs are removed in case the SVLs are not operating correctly. Removal of the SVLs from all cables will prevent <i>ACR Current</i> flowing between the earth mats along the cable sheaths.

For guidance on the use of AREA 15C, AREA 3C or AREA 3D refer to section 4.3 of this document.

For multiple work locations on cables or their accessories refer to section 8.1 of this document.

CONFIGURATION G – AREA 16A AND AREA 16B

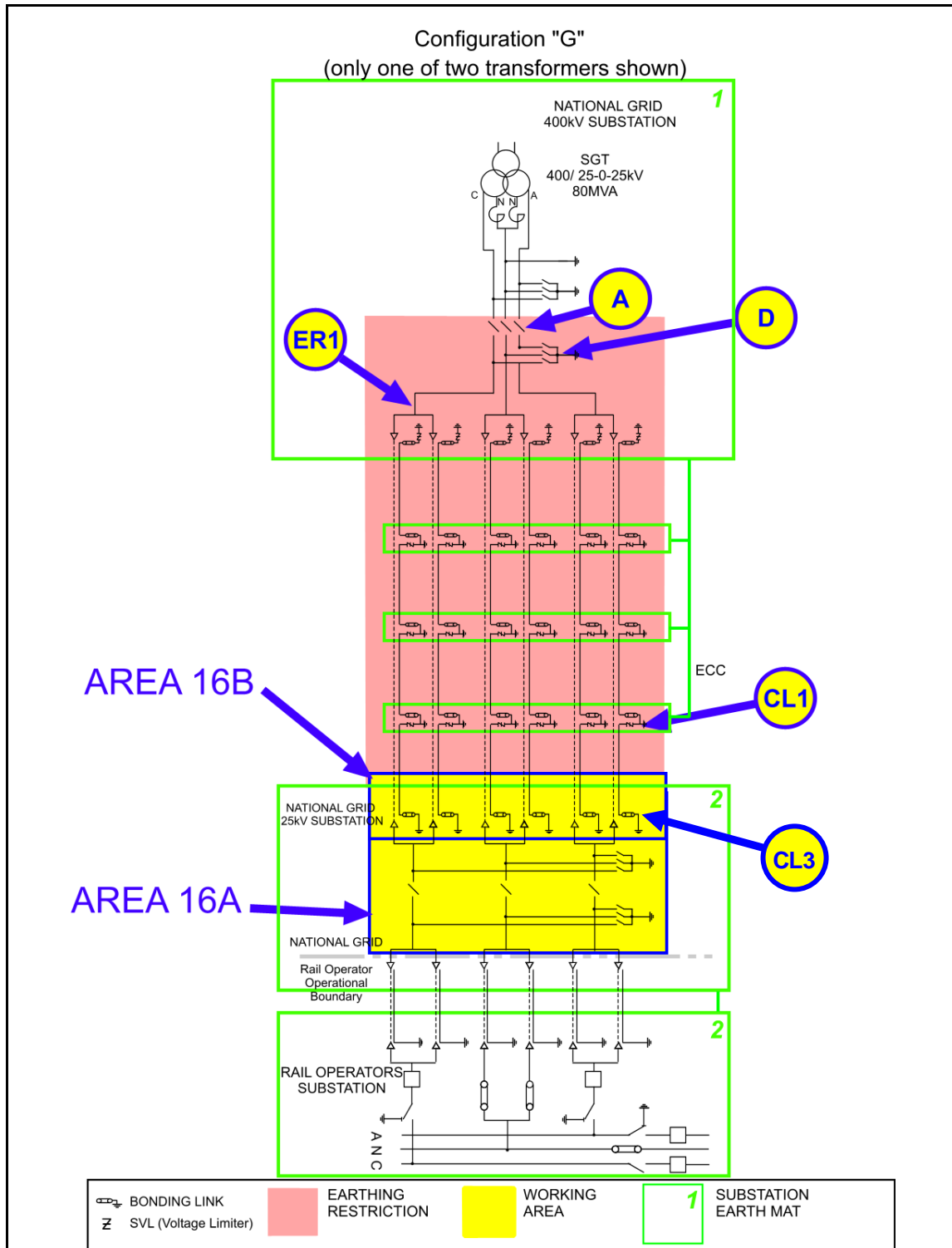

The following table is not a switching sequence. A **Senior Authorised Person** shall include the following tabulated precautions required on **Equipment** as part of a switching, isolating and earthing sequence to eliminate *ACR Current* from the designated working AREA.

AREA 16A

Equipment	Precautions Required	Reason
Disconnectors A	Check open, lock and apply the "Do Not Close Notice"	Disconnect conductors from 25kV substation and rail operators system and stop <i>ACR Current</i> between earth mats, via the pole and <i>Neutral Conductors</i> , find a return path through the transformer earth.
Earth Switch D	Open Earth Switch D and apply the "Do Not Earth Conductors Notice".	This precaution is necessary to prevent <i>ACR Current</i> flowing along conductors if an earth is placed on a conductor, which would create a parallel path for <i>ACR Current(s)</i> .
<i>Earthing restriction zone</i> ER1.	Do not apply earths on Equipment inside region ER1.	This precaution is necessary to prevent <i>ACR Current</i> flowing along conductors if an earth is placed on a conductor, which would create a parallel path for <i>ACR Current(s)</i> .

AREA 16B

If works are required on, or that may infringe **Safety Distance** to, the Cables, Cable Sealing Ends or Cable Sheath connections then the following additional requirement to those for AREA 16A applies.

Cable sheath voltage limiters (SVLs) CL1.	Remove the sheath voltage limiter in accordance with the principles of NSI 5. Apply the "Do Not Earth Conductors Notice".	These SVLs are to be removed in case the SVLs are not operating correctly. Removal of the SVLs from all cables will prevent <i>ACR Current</i> flowing between the earth mats along the cable sheaths. NOTE: The cable bonding links "CL3" at the solidly bonded position shall be removed prior to removing / replacing the links "CL1" at an SVL position. "CL3" shall not be quoted as an <i>ACR</i> precaution.
---	---	--

For guidance on the use of AREA 16B or AREA 3D refer to section 4.3 of this document.

For multiple work locations on cables or their accessories refer to section 8.1 of this document.

CONFIGURATION H

CONFIGURATION H – AREA 1

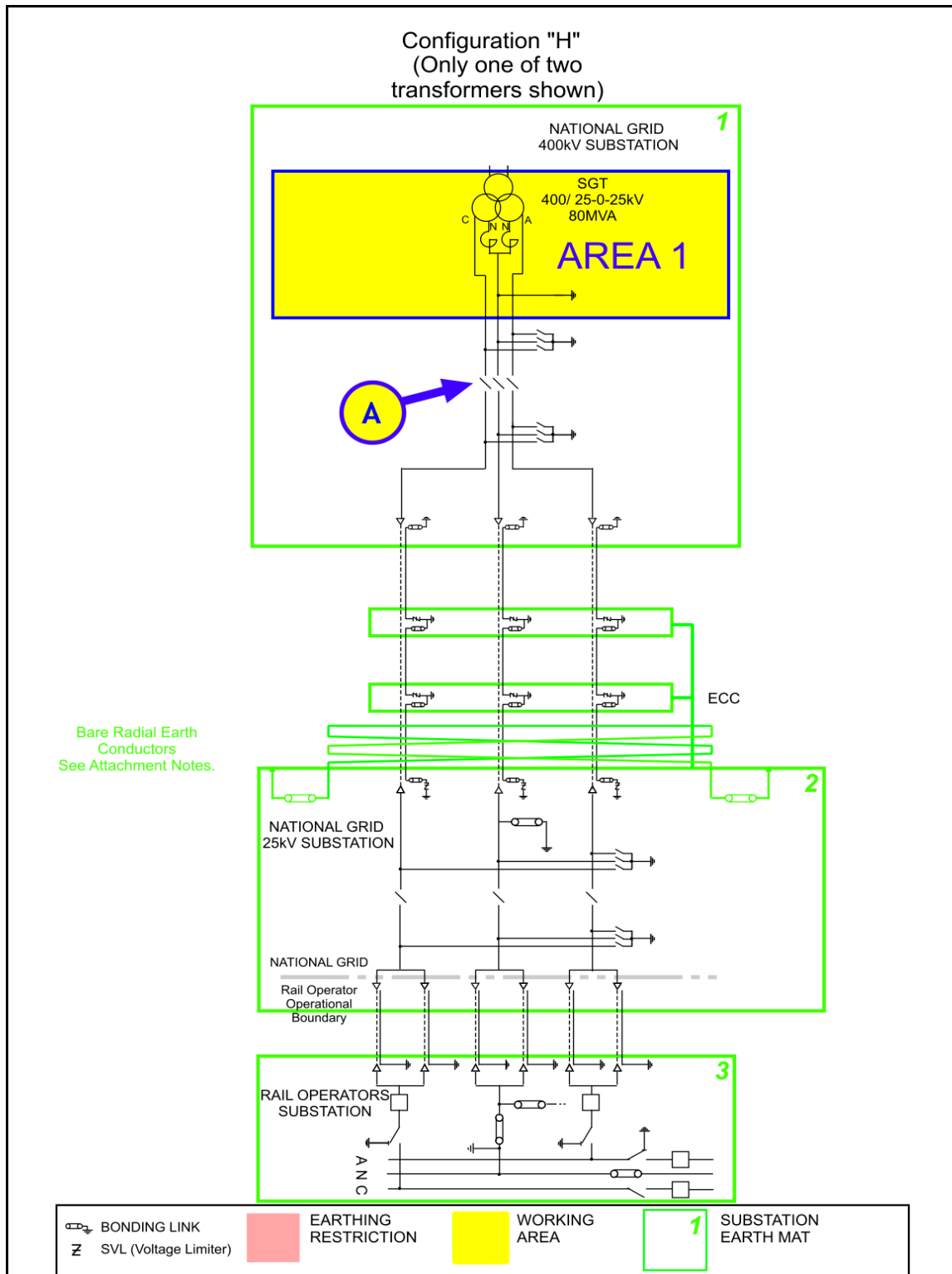

The following table is not a switching sequence. A **Senior Authorised Person** shall include the following tabulated precautions required on **Equipment** as part of a switching, isolating and earthing sequence to eliminate *ACR Current* from the designated working AREA.

AREA 1

Equipment	Precautions Required	Reason
Disconnecter A	Check open, lock and apply the "Do Not Close Notice"	To prevent any <i>ACR Current</i> from finding a return path through the work area.

CONFIGURATION H – AREA 2A AND AREA 2B

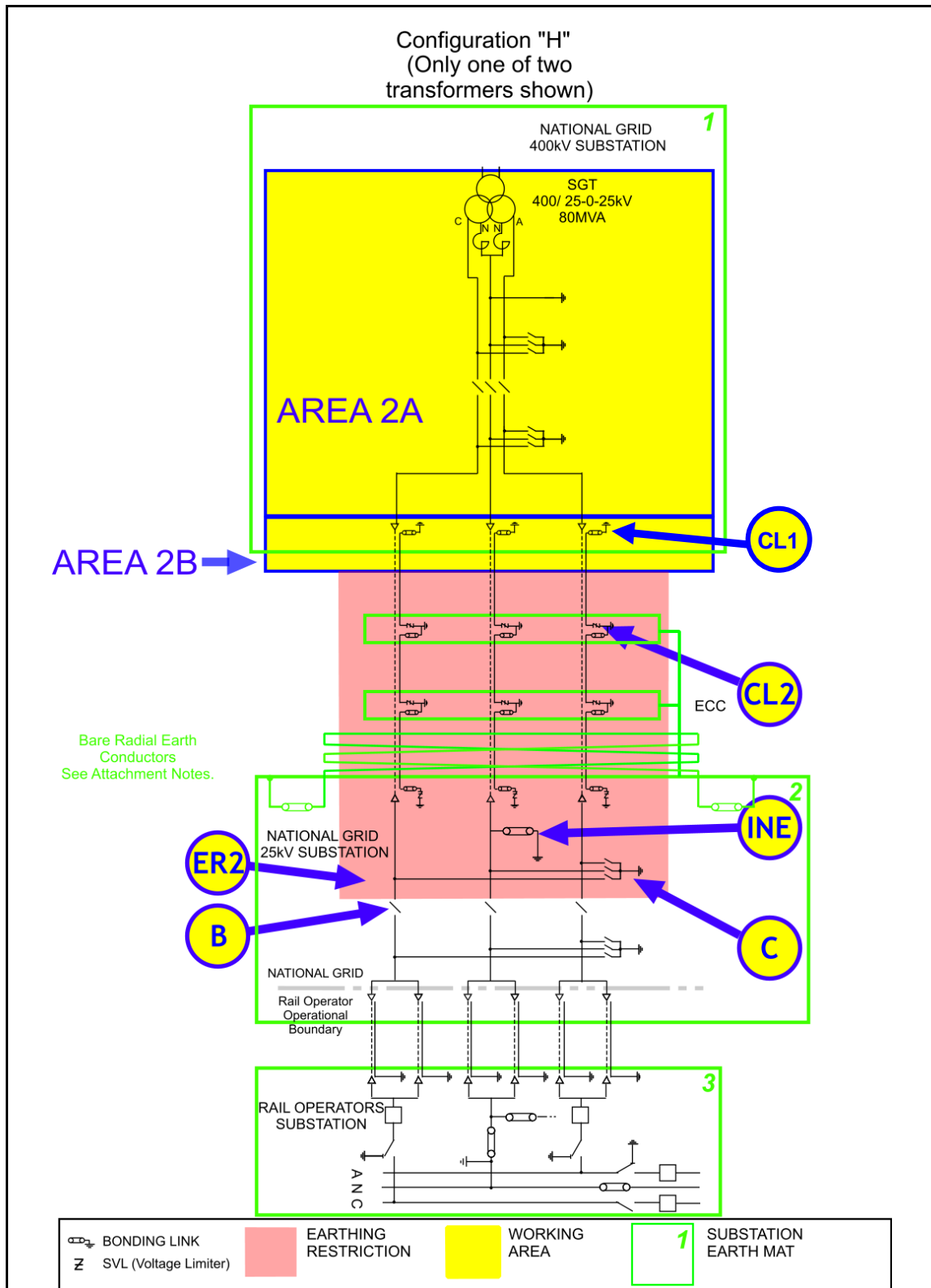

The following table is not a switching sequence. A **Senior Authorised Person** shall include the following tabulated precautions required on **Equipment** as part of a switching, isolating and earthing sequence to eliminate *ACR Current* from the designated working AREA.

AREA 2A

Equipment	Precautions Required	Reason
Disconnectors B	Check open, lock and apply the "Do Not Close Notice"	Disconnect conductors from 25kV substation and rail operators System to stop <i>ACR Current</i> between earth mats via the pole and <i>Neutral Conductors</i> .
Intermediate Neutral Earth Link, <i>INE</i>	Remove earth link in accordance to the principles of Section 6 and apply the "Do Not Earth Conductors Notice".	This precaution is necessary to prevent <i>ACR Current</i> flowing along the <i>Neutral Conductor</i> when an earth is placed on the <i>Neutral Conductor</i> in the work area. (Earth Switch C should be closed during this operation)
Earth Switch C	Open Earth Switch C and apply the "Do Not Earth Conductors Notice"	This precaution is necessary, as an earth on any of the Poles or <i>Neutral Conductor</i> will create a parallel path through which <i>ACR Current</i> will flow.
Earth restriction region ER2	Do not apply earths on Equipment inside regions ER2.	This precaution is necessary, as an earth on any of the Poles, <i>Neutral Conductor</i> or Cable Sheath will create a parallel path through which <i>ACR Current</i> will flow.

AREA 2B

If works are required on, or that could infringe a **Safety Distance** to, the cables, cable sealing ends or cable sheath connections then the following additional requirement to those for AREA 2A applies.

Cable sheath bonding links (SVL's) CL2.	Remove the sheath voltage limiter in accordance with the principles of NSI 5. Apply the "Do Not Earth Conductors Notice".	Removal of the sheath voltage limiters will prevent <i>ACR Current</i> flowing between the earth mats along the cable sheaths. NOTE: The cable bonding links "CL1" at the solidly bonded position shall be removed prior to removing / replacing the links "CL2" at an SVL position. "CL1" shall not be quoted as an ACR precaution.
---	---	---

For guidance on the use of AREA 2B refer to section 4.3 of this document.

For multiple work locations on cables or their accessories refer to section 8.1 of this document.

CONFIGURATION H – AREA 3E

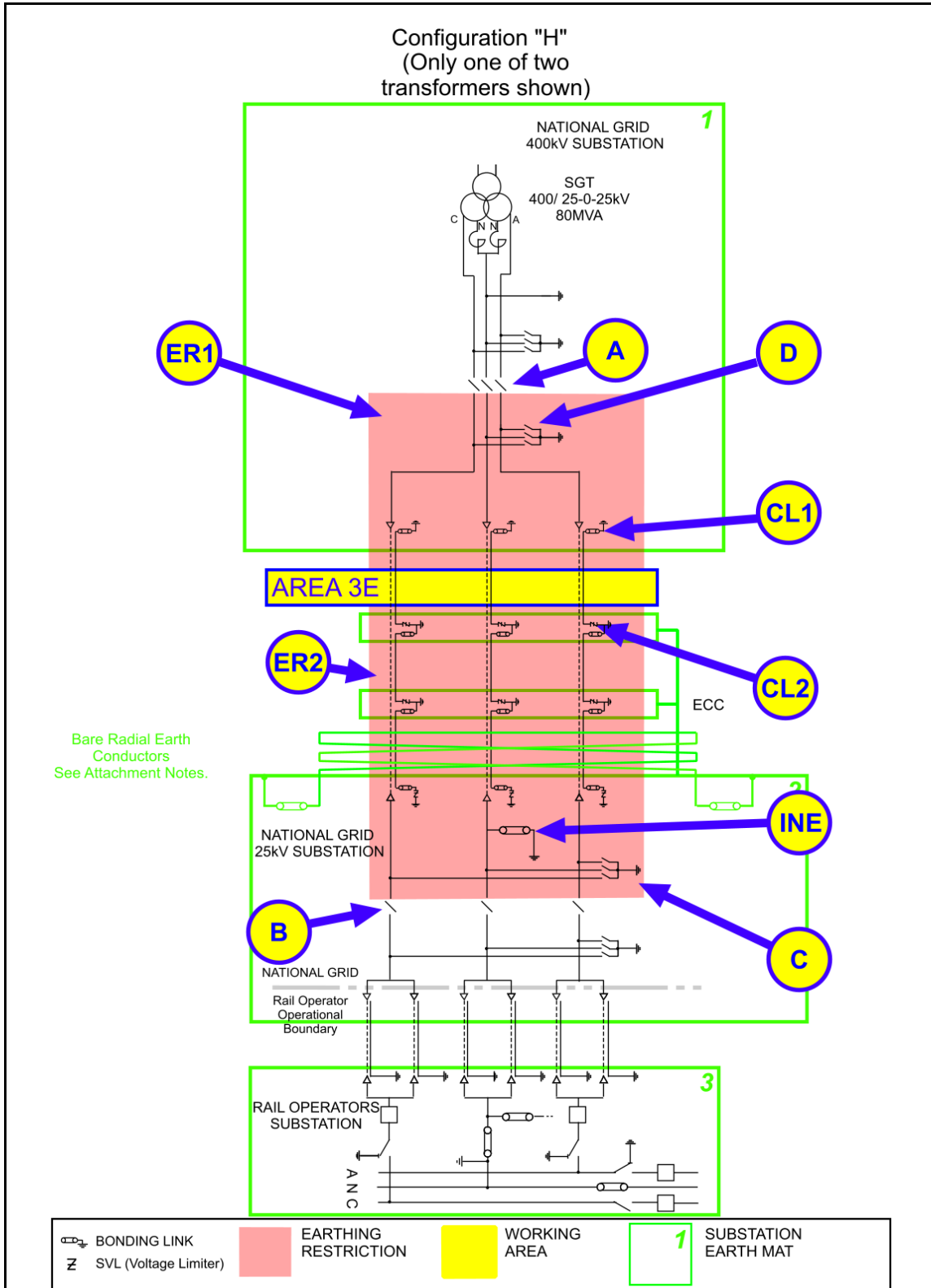

The following table is not a switching sequence. A **Senior Authorised Person** shall include the following tabulated precautions required on **Equipment** as part of a switching, isolating and earthing sequence to eliminate *ACR Current* from the designated working AREA.

AREA 3E

Equipment	Precautions Required	Reason
Disconnectors A and B	Check open, lock and apply the "Do Not Close Notice"	Avoid <i>ACR Current</i> in conductors between the 25kV and 400kV substations from the rail operator's System .
Intermediate Neutral Earth Link, <i>INE</i>	Remove earth link in accordance to the principles of Section 6 and apply the "Do Not Earth Conductors Notice".	This precaution is necessary to prevent <i>ACR Current</i> flowing along the <i>Neutral Conductor</i> when an earth is placed on the <i>Neutral Conductor</i> in the work area. (Earth Switch C should be closed during this operation)
Earth Switches C and D	Open Earth Switches and apply the "Do not Earth Conductors Notice"	This precaution is necessary to prevent <i>ACR Current</i> flowing along the cable and through the mass of earth when an earth is placed on a cable conductor or sheath in the work area.
<i>Earthing restriction zones</i> ER1 and ER2.	Do not apply earths on Equipment inside regions ER1 or ER2.	This precaution is necessary to prevent <i>ACR Current</i> flowing along the cable and through the mass of earth when an earth is placed on a cable conductor or sheath in the work area. The placing of an earth in the restricted region(s) would create an alternative path for <i>ACR Current(s)</i> .
Cable sheath bonding links CL1.	Remove cable sheath earth and bonding links Apply the "Do not Earth Conductors Notice".	These cable earth bonding links are removed in case the SVLs at CL2 are not operating correctly. Removal of the cable sheath bonding links from all cables will prevent <i>ACR Current</i> flowing between the earth mats via the cable sheaths. The cable bonding links "CL1" at the solidly bonded position shall be removed prior to removing the links "CL2" at an SVL position. This will avoid <i>ACR Current(s)</i> flowing during the application of Earthing Devices.
Cable sheath SVLs, CL2.	Remove the cable sheath voltage limiters in accordance with the principles of NSI 5. Apply the "Do Not Earth Conductors Notice".	Removal of the SVLs from all cables will prevent <i>ACR Current</i> flowing between the earth mats along the cable sheaths.

For guidance on the use of AREA 3E refer to section 4.3 of this document.

For multiple work locations on cables or their accessories refer to section 8.1 of this document.

For work on the cable circuit *ECC* see the notes for arrangement H at the end of this section.

CONFIGURATION H – AREA 3F

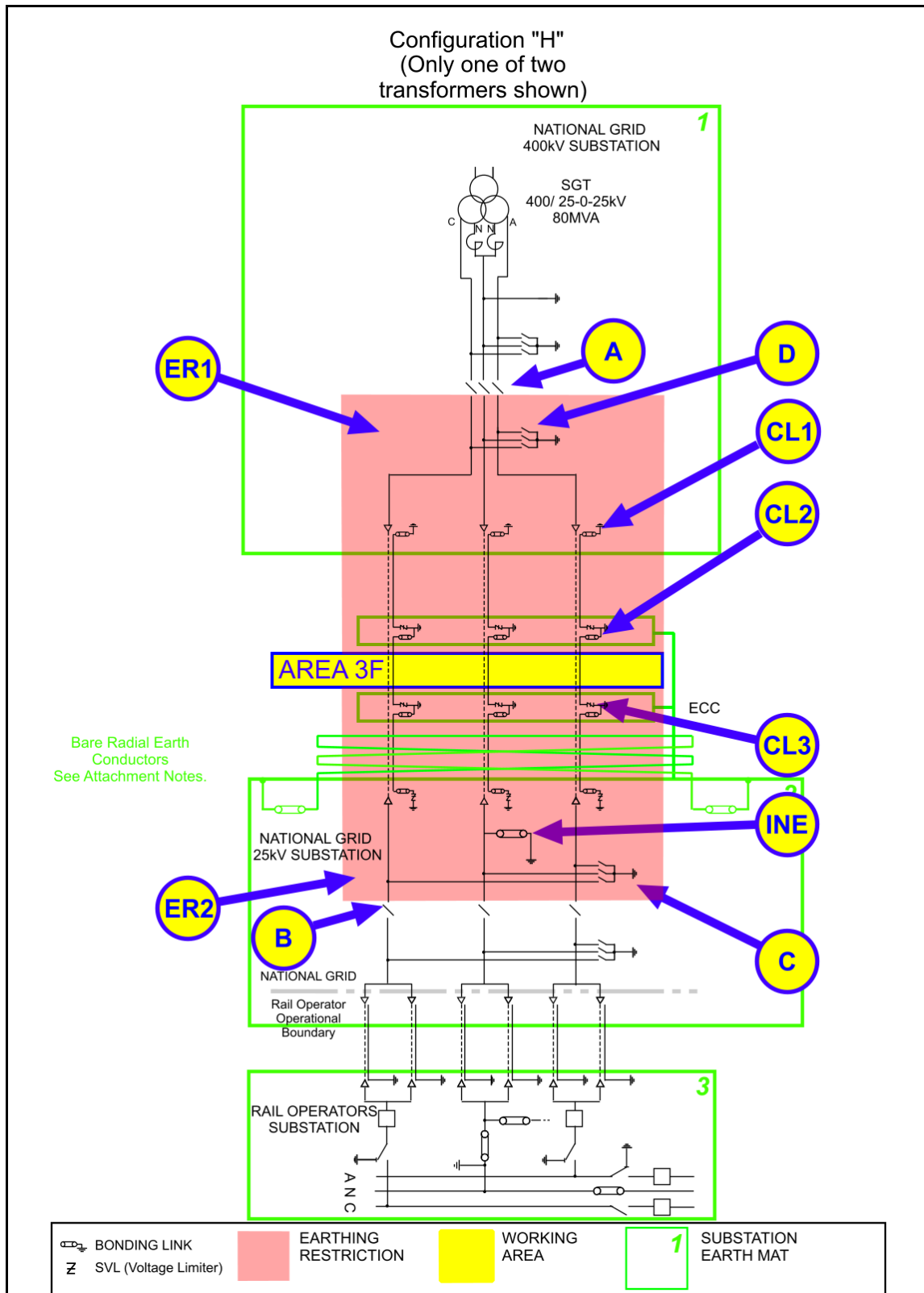

The following table is not a switching sequence. A **Senior Authorised Person** shall include the following tabulated precautions required on **Equipment** as part of a switching, isolating and earthing sequence to eliminate *ACR Current* from the designated working AREA.

AREA 3F

Equipment	Precautions Required	Reason
Disconnectors A and B	Check open, lock and apply the "Do Not Close Notice"	Avoid <i>ACR Current</i> in conductors between the 25kV and 400kV substations from the rail operator's System .
Intermediate Neutral Earth Link, <i>INE</i>	Remove earth link in accordance to the principles of Section 6 and apply the "Do Not Earth Conductors Notice".	This precaution is necessary to prevent <i>ACR Current</i> flowing along the <i>Neutral Conductor</i> when an earth is placed on the <i>Neutral Conductor</i> in the work area. (Earth Switch C should be closed during this operation)
Earth Switches C and D	Open Earth Switches and apply the "Do not Earth Conductors Notice"	This precaution is necessary to prevent <i>ACR Current</i> flowing along the cable and through the mass of earth when an earth is placed on a cable conductor or sheath in the work area.
<i>Earthing restriction zones</i> ER1 and ER2.	Do not apply earths on Equipment inside regions ER1 or ER2.	This precaution is necessary to prevent <i>ACR Current</i> flowing along the cable and through the mass of earth when an earth is placed on a cable conductor or sheath in the work area. The placing of an earth in the restricted region(s) would create an alternative path for <i>ACR Current(s)</i> .
Cable sheath bonding links, CL1.	Remove the cable sheath bonding link. Apply the "Do Not Earth Conductors Notice".	These cable sheath bonding links are removed in case the SVLs on the same cable section are not operating correctly. Removal of the cable sheath bonding links from all cables will prevent <i>ACR Current</i> flowing along the cable sheaths to the 400kV substation earth mat. The cable bonding links "CL1" at the solidly bonded position shall be removed prior to removing the links "CL2" at an SVL position. This will avoid <i>ACR Current(s)</i> flowing during the application of Earthing Devices.
Cable sheath bonding links, CL2.	Remove the sheath links in accordance with the principles of NSI 5. Apply the "Do Not Earth Conductors Notice".	These links are removed to prevent <i>ACR Current</i> flowing between the earth mats along the cable sheaths.
Cable SVL's, CL3.	Remove the sheath voltage limiter in accordance with the principles of NSI 5. Apply the "Do Not Earth Conductors Notice".	These SVLs are removed in case the SVLs are not operating correctly. Removal of the SVLs from all cables will prevent <i>ACR Current</i> flowing between the earth mats along the cable sheaths.

For guidance on the use of AREA 3F refer to section 4.3 of this document.

For multiple work locations on cables or their accessories refer to section 8.1 of this document.

For work on the cable circuit Earth *ECC* see the notes for arrangement H at the end of this section.

CONFIGURATION H – AREA 3G

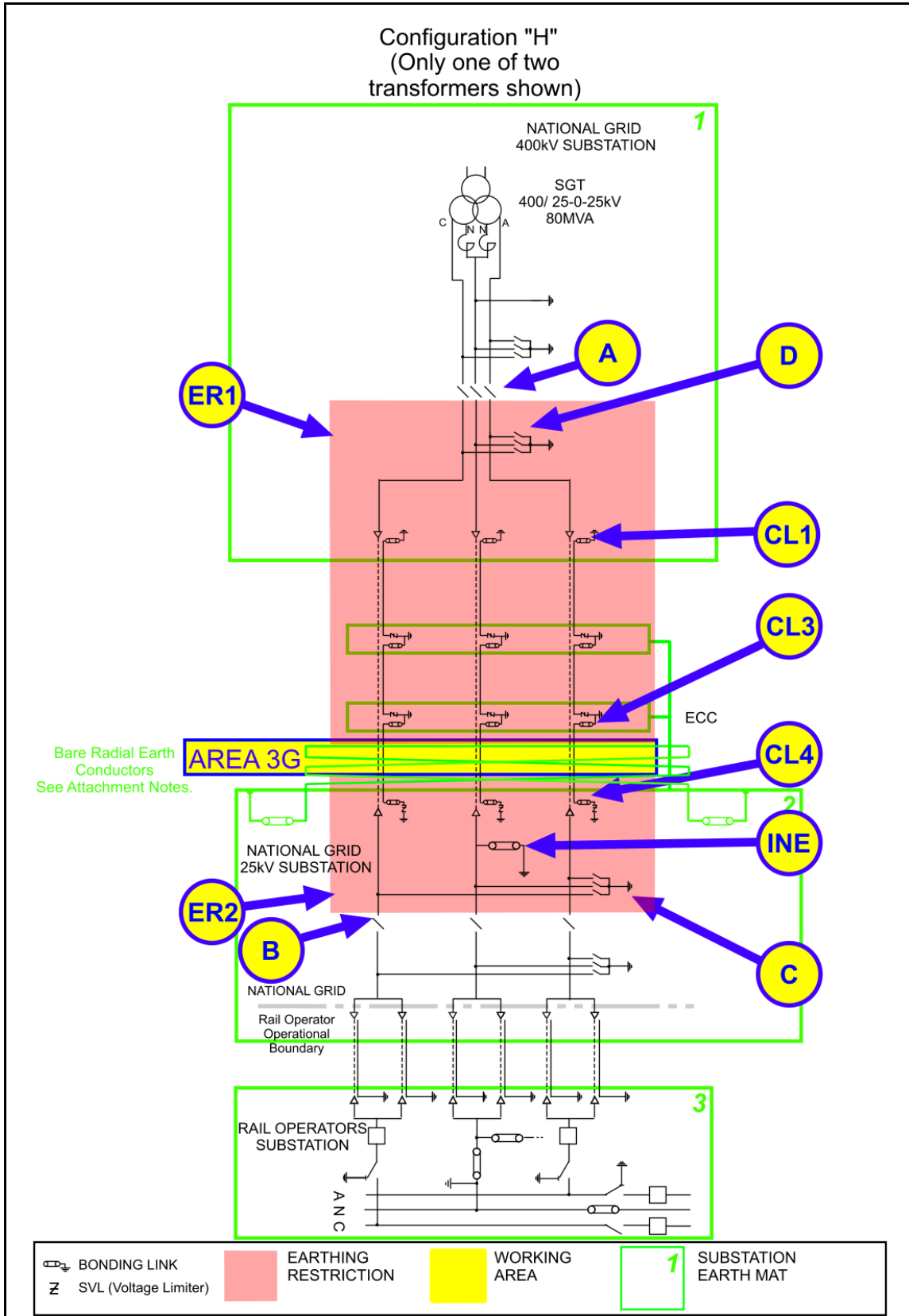

The following table is not a switching sequence. A **Senior Authorised Person** shall include the following tabulated precautions required on **Equipment** as part of a switching, isolating and earthing sequence to eliminate *ACR Current* from the designated working AREA.

AREA 3G

Equipment	Precautions Required	Reason
Disconnectors A and B	Check open, lock and apply the "Do Not Close Notice"	Avoid <i>ACR Current</i> in conductors between the 25kV and 400kV substations from the rail operator's System .
Intermediate Neutral Earth Link, <i>INE</i>	Remove earth link in accordance to the principles of Section 6 and apply the "Do Not Earth Conductors Notice".	This precaution is necessary to prevent <i>ACR Current</i> flowing along the <i>Neutral Conductor</i> when an earth is placed on the <i>Neutral Conductor</i> in the work area. (Earth Switch C should be closed during this operation)
Earth Switches C and D	Open Earth Switches and apply the "Do not Earth Conductors Notice"	This precaution is necessary to prevent <i>ACR Current</i> flowing along the cable and through the mass of earth when an earth is placed on a cable conductor or sheath in the work area.
<i>Earthing restriction zones</i> ER1 and ER2.	Do not apply earths on Equipment inside regions ER1 or ER2.	This precaution is necessary to prevent <i>ACR Current</i> flowing along the cable and through the mass of earth when an earth is placed on a cable conductor or sheath in the work area. The placing of an earth in the restricted region(s) would create an alternative path for <i>ACR Current(s)</i> .
Cable sheath bonding links, CL1.	Remove the cable sheath bonding link. Apply the "Do Not Earth Conductors Notice".	These cable sheath bonding links are removed in case the SVLs on the same cable section are not operating correctly. Removal of the cable sheath bonding links from all cables will prevent <i>ACR Current</i> flowing along the cable sheaths to the 400kV substation earth mat.
Cable sheath bonding links, CL3.	Remove the sheath links in accordance with the principles of NSI 5. Apply the "Do Not Earth Conductors Notice".	These links are removed to prevent <i>ACR Current</i> flowing between the earth mats along the cable sheaths. The cable bonding links "CL3" at the solidly bonded position shall be removed prior to removing the links "CL4" at an SVL position. This will avoid <i>ACR Current(s)</i> flowing during the application of Earthing Devices.
Cable sheath bonding links, CL4.	Remove cable sheath earth and bonding links. Apply the "Do not Earth Conductors Notice".	These links are to be removed in case the SVLs are not operating correctly. Removal of the links from all cables will prevent <i>ACR Current</i> flowing between the earth mats along the cable sheaths.

Any maintenance on, or connection to, the radial earth must follow the requirements of NSI 24. The radial earth may carry **System** earth current even when a 25kV circuit is de-energised.

For guidance on the use of AREA 3G refer to section 4.3 of this document.

The radial earth conductor must not be used as a local earth during cable repairs. This will avoid circulating current(s); see the notes for arrangement H at the end of this section.

For multiple work locations on cables or their accessories refer to section 8.1 of this document.

For work on the cable circuit *ECC* see the notes for arrangement H at the end of this section.

CONFIGURATION H – AREA 15D

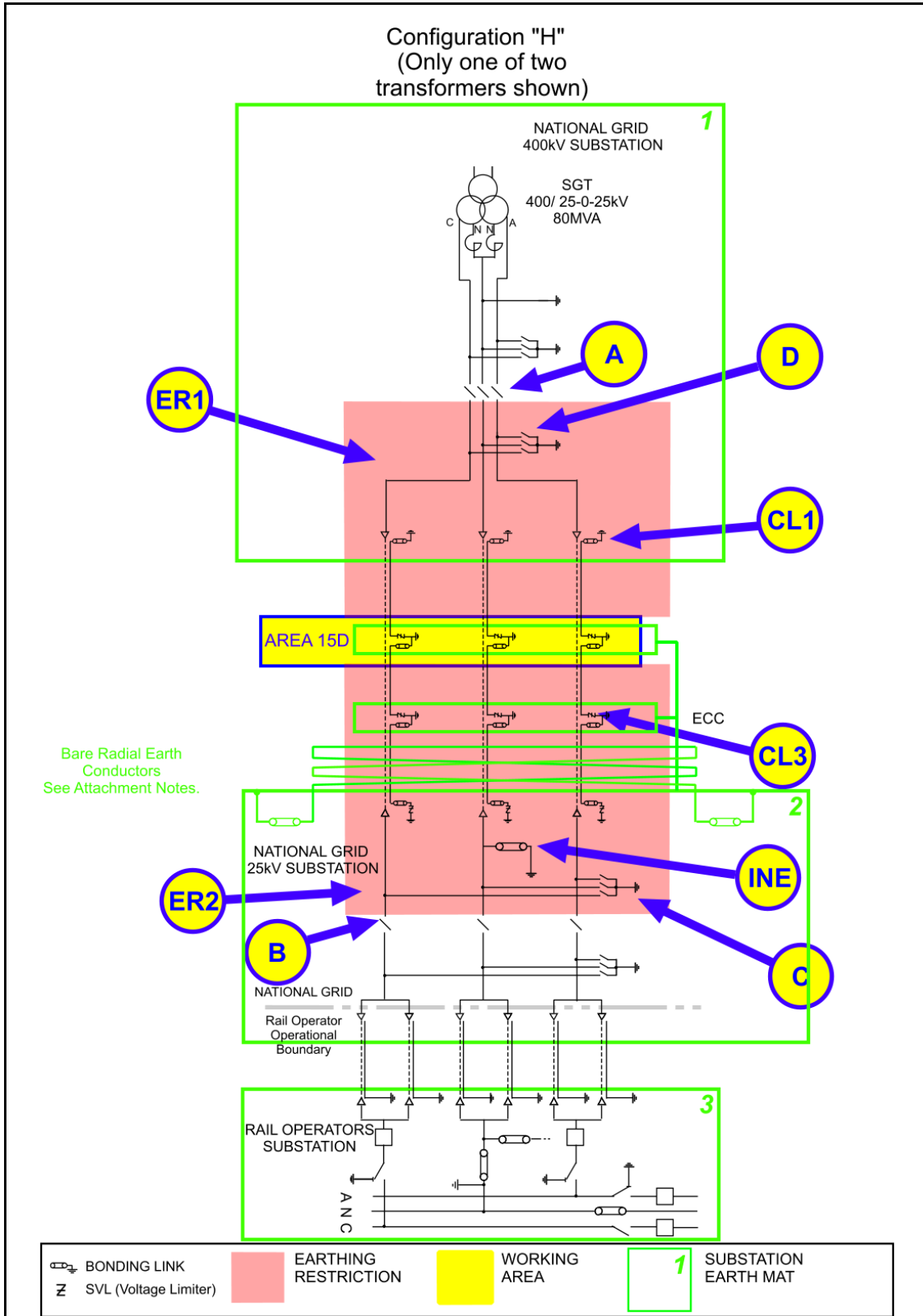

The following table is not a switching sequence. A **Senior Authorised Person** shall include the following tabulated precautions required on **Equipment** as part of a switching, isolating and earthing sequence to eliminate *ACR Current* from the designated working AREA.

AREA 15D

Equipment	Precautions Required	Reason
Disconnectors A and B	Check open, lock and apply the "Do Not Close Notice"	Avoid <i>ACR Current</i> in conductors between the 25kV and 400kV substations from the rail operator's System .
Intermediate Neutral Earth Link, <i>INE</i>	Remove earth link in accordance to the principles of Section 6 and apply the "Do Not Earth Conductors Notice".	This precaution is necessary to prevent <i>ACR Current</i> flowing along the <i>Neutral Conductor</i> when an earth is placed on the <i>Neutral Conductor</i> in the work area. (Earth Switch C should be closed during this operation)
Earth Switches C and D	Open Earth Switches and apply the "Do not Earth Conductors Notice"	This precaution is necessary to prevent <i>ACR Current</i> flowing along the cable and through the mass of earth when an earth is placed on a cable conductor or sheath in the work area.
<i>Earthing restriction zones</i> ER1 and ER2.	Do not apply earths on Equipment inside regions ER1 or ER2.	This precaution is necessary to prevent <i>ACR Current</i> flowing along the cable and through the mass of earth when an earth is placed on a cable conductor or sheath in the work area. The placing of an earth in the restricted region(s) would create an alternative path for <i>ACR Current(s)</i> .
Cable sheath bonding links CL1.	Remove cable sheath earth and bonding. Apply the "Do not Earth Conductors Notice".	Removal of the links from all cables will prevent <i>ACR Current</i> flowing between the earth mats along the cable sheaths. The cable bonding links "CL1" at the solidly bonded position shall be removed prior to removing the links "CL2" at an SVL position. This will avoid <i>ACR Current(s)</i> flowing during the application of Earthing Devices.
Cable sheath SVL links CL3.	Remove the sheath voltage limiter in accordance with the principles of NSI 5. Apply the "Do Not Earth Conductors Notice".	These sheath voltage limiters are to be removed in case they are not operating correctly. Removal of the SVLs from all cables will prevent <i>ACR Current</i> flowing between the earth mats along the cable sheaths.

For guidance on the use of AREA 15D refer to section 4.3 of this document.

For multiple work locations on cables or their accessories refer to section 8.1 of this document.

For work on the cable circuit *ECC* see the notes for arrangement H at the end of this section.

CONFIGURATION H – AREA 15E

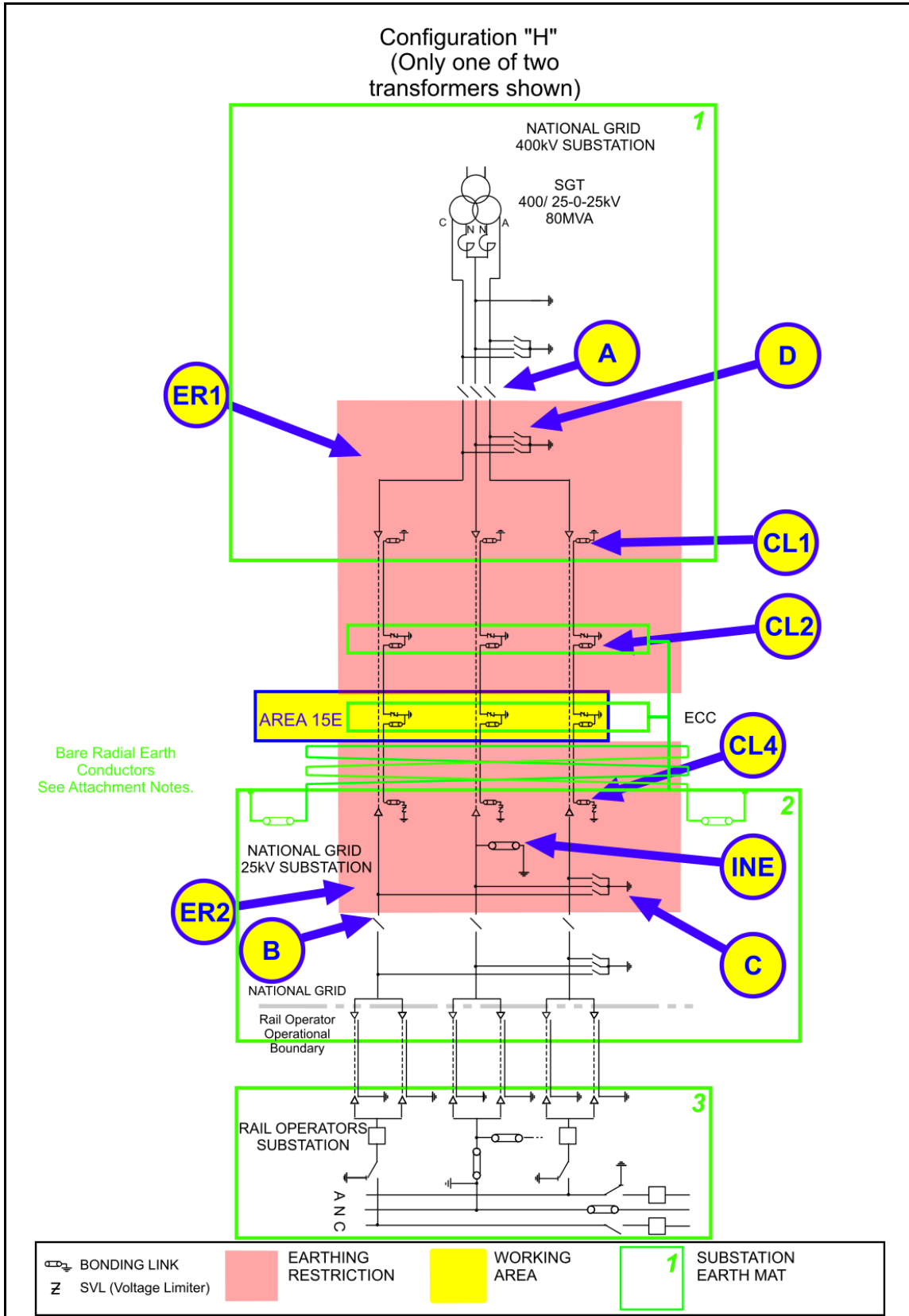

The following table is not a switching sequence. A **Senior Authorised Person** shall include the following tabulated precautions required on **Equipment** as part of a switching, isolating and earthing sequence to eliminate *ACR Current* from the designated working AREA.

AREA 15E

Equipment	Precautions Required	Reason
Disconnectors A and B	Check open, lock and apply the "Do Not Close Notice"	Avoid <i>ACR Current</i> in conductors between the 25kV and 400kV substations from the rail operator's System .
Intermediate Neutral Earth Link, <i>INE</i>	Remove earth link in accordance to the principles of Section 6 and apply the "Do Not Earth Conductors Notice".	This precaution is necessary to prevent <i>ACR Current</i> flowing along the <i>Neutral Conductor</i> when an earth is placed on the <i>Neutral Conductor</i> in the work area. (Earth Switch C should be closed during this operation)
Earth Switches C and D	Open Earth Switches and apply the "Do not Earth Conductors Notice"	This precaution is necessary to prevent <i>ACR Current</i> flowing along the cable and through the mass of earth when an earth is placed on a cable conductor or sheath in the work area.
<i>Earthing restriction zones</i> ER1 and ER2.	Do not apply earths on Equipment inside regions ER1 or ER2.	This precaution is necessary to prevent <i>ACR Current</i> flowing along the cable and through the mass of earth when an earth is placed on a cable conductor or sheath in the work area. The placing of an earth in the restricted region(s) would create an alternative path for <i>ACR Current(s)</i> .
Cable sheath bonding links, CL1.	Remove the cable sheath bonding link. Apply the "Do Not Earth Conductors Notice".	These cable sheath bonding links are removed in case the SVLs on the same cable section are not operating correctly. Removal of the cable sheath bonding links from all cables will prevent <i>ACR Current</i> flowing along the cable sheaths to the 400kV substation earth mat.
Cable sheath bonding links, CL2.	Remove the sheath links in accordance with the principles of NSI 5. Apply the "Do Not Earth Conductors Notice".	These links are removed to prevent <i>ACR Current</i> flowing between the earth mats along the cable sheaths. The cable bonding links "CL2" at the solidly bonded position shall be removed prior to removing the links "CL3" at an SVL position. This will avoid <i>ACR Current(s)</i> flowing during the application of Earthing Devices.
Cable sheath bonding links, CL4.	Remove cable sheath earth and bonding links. Apply the "Do not Earth Conductors Notice".	These links are to be removed in case the SVLs are not operating correctly. Removal of the links from all cables will prevent <i>ACR Current</i> flowing between the earth mats along the cable sheaths.

For guidance on the use of AREA 15E refer to section 4.3 of this document.

For multiple work locations on cables or their accessories refer to section 8.1 of this document.

For work on the cable circuit *ECC* see the notes for arrangement H at the end of this section.

CONFIGURATION H – AREA 17A AND AREA 17B

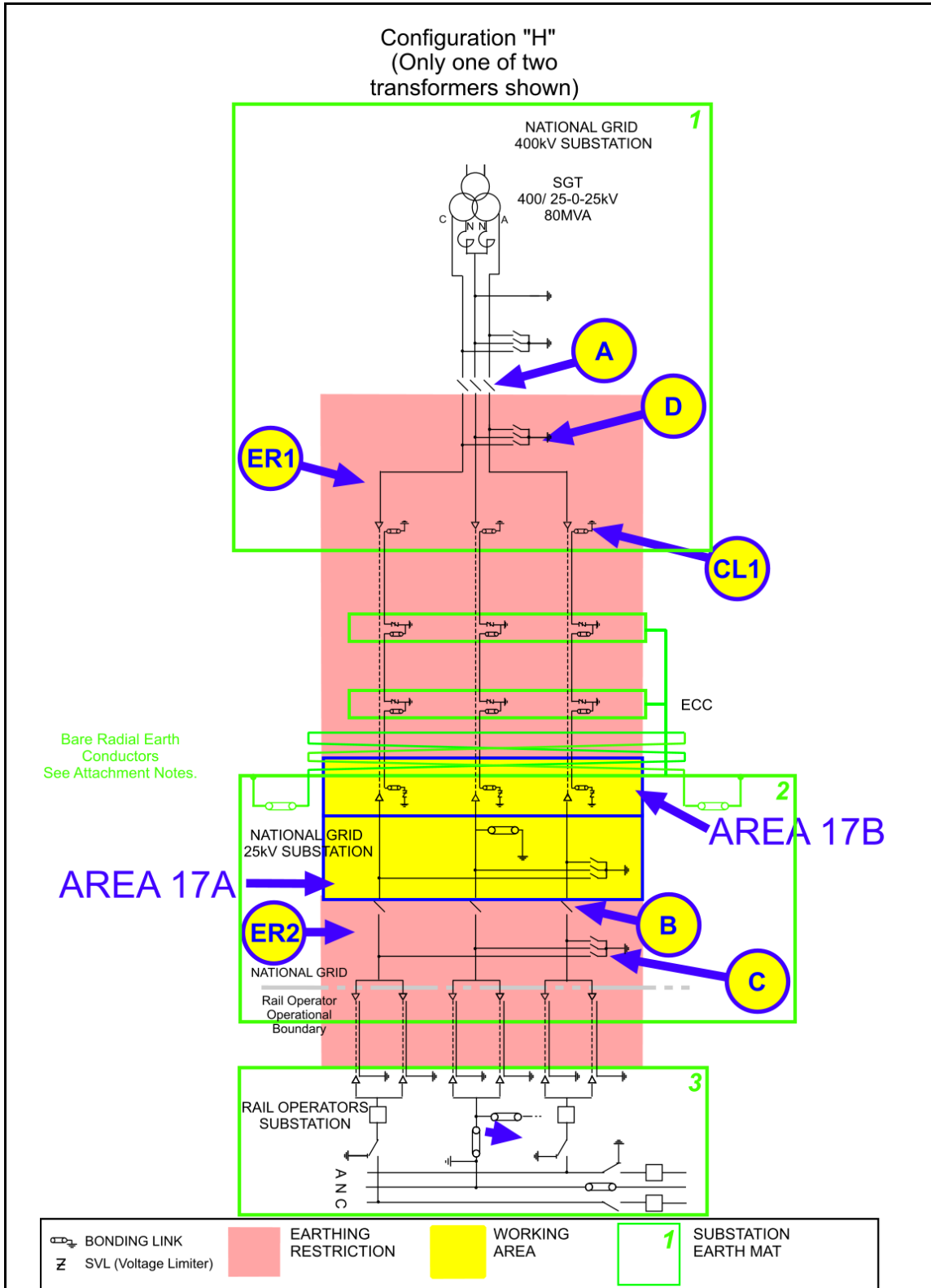

The following table is not a switching sequence. A **Senior Authorised Person** shall include the following tabulated precautions required on **Equipment** as part of a switching, isolating and earthing sequence to eliminate *ACR Current* from the designated working AREA.

AREA 17A

Equipment	Precautions Required	Reason
Disconnectors A and B	Check open, lock and apply the "Do Not Close Notice"	Disconnect conductors from 25kV substation and rail operators system and stop <i>ACR Current</i> between earth mats, via the pole and <i>Neutral Conductors</i> , from finding a return path through the transformer earth.
Earth Switches C and D	Open Earth Switch D and apply the "Do Not Earth Conductors Notice".	This precaution is necessary to prevent <i>ACR Current</i> flowing along conductors if an earth is placed on a conductor, which would create a parallel path for <i>ACR Current(s)</i> .
<i>Earthing restriction zone</i> ER1 and ER2.	Do not apply earths on Equipment inside region ER1.	This precaution is necessary to prevent <i>ACR Current</i> flowing along conductors if an earth is placed on a conductor, which would create a parallel path for <i>ACR Current(s)</i> .

AREA 17B

If works are required on, or that may infringe **Safety Distance** to, the Cables, Cable Sealing Ends or Cable Sheath connections then the following additional requirement to those for AREA 17A applies.

Cable sheath bonding links CL1.	Remove cable sheath earth and bonding links. Apply the "Do not Earth Conductors Notice".	Removal of the bonding link from all cables will prevent <i>ACR Current</i> flowing between the earth mats along the cable sheaths.
---------------------------------	--	---

For guidance on the use of AREA 17B refer to section 4.3 of this document.

The radial earth conductor must not be used as a local earth during cable repairs. This will avoid circulating current(s); see the notes for arrangement H at the end of this section.

For multiple work locations on cables or their accessories refer to section 8.1 of this document.

For work on the cable circuit *ECC* see the notes for arrangement H at the end of this section.

CONFIGURATION H – AREA 18

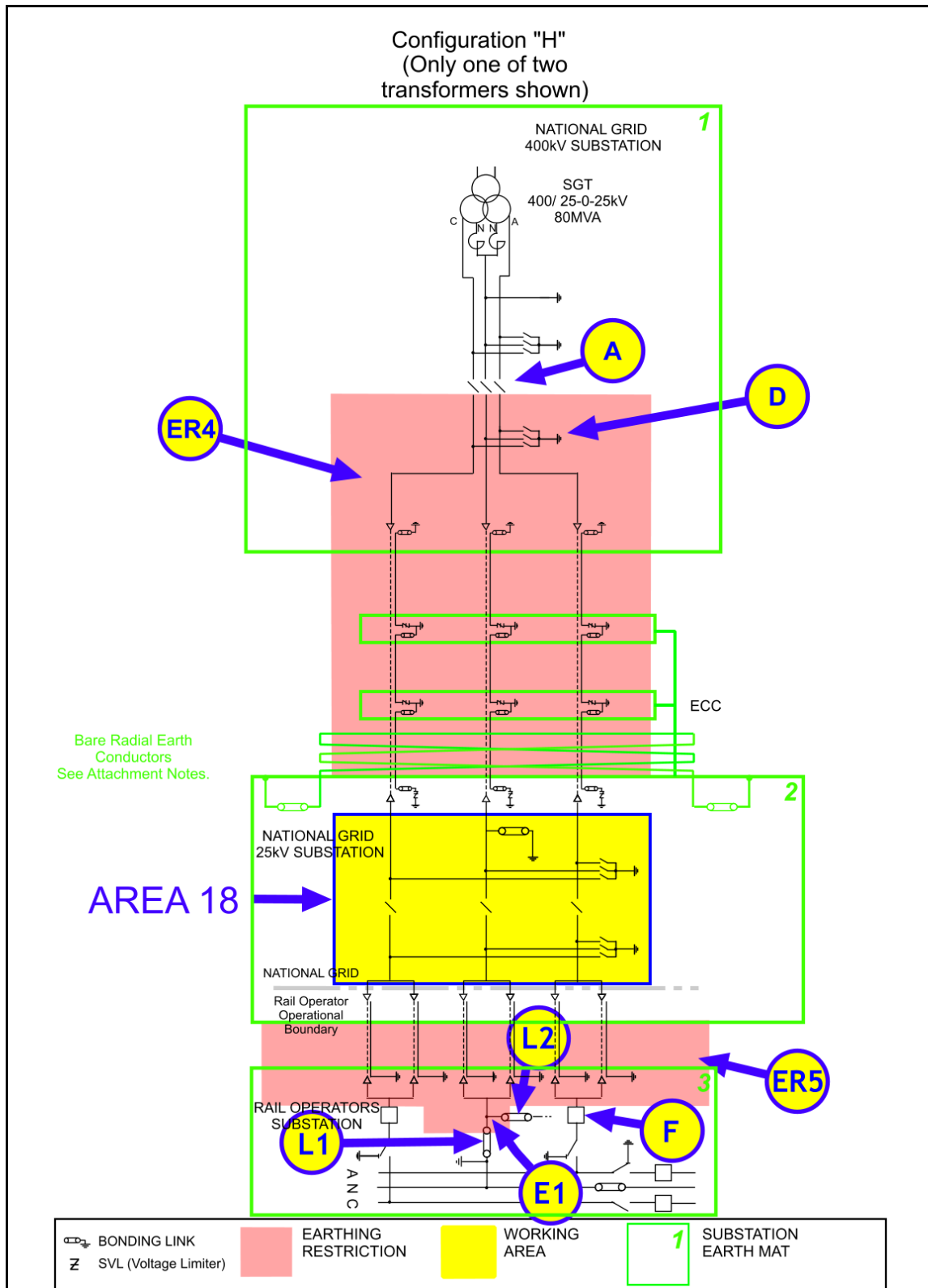

The following table is not a switching sequence. A **Senior Authorised Person** shall include the following tabulated precautions required on **Equipment** as part of a switching, isolating and earthing sequence to eliminate *ACR Current* from the designated working AREA.

AREA 18

Equipment	Precautions Required	Reason
Disconnecter A	Check open, lock and apply the "Do Not Close Notice"	Disconnect conductors from 25kV substation and rail operators system and stop <i>ACR Current</i> between earth mats, via the pole and <i>Neutral Conductors</i> , from finding a return path through the transformer earth.
Earth Switch D	Open Earth Switch D and apply the "Do Not Earth Conductors Notice".	This precaution is necessary to prevent <i>ACR Current</i> flowing along conductors if an earth is placed on a conductor, which would create a parallel path for <i>ACR Current(s)</i> .
<i>Earthing restriction zone</i> ER4 and ER5.	Do not apply earths on Equipment inside region ER1.	This precaution is necessary to prevent <i>ACR Current</i> flowing along conductors if an earth is placed on a conductor, which would create a parallel path for <i>ACR Current(s)</i> .
Rail Operators Equipment Circuit Breaker F	Locked Open	To stop any <i>ACR</i> current flow through the point of work and the <i>C</i> and <i>A poles</i> as a result of any earths being placed on the pole conductors in the rail operators system.
Rail Operators Equipment Links L1, L2 and Earth Position E1	Remove rail operator neutral links and ensure there is no earth applied to return conductor at position E1.	To stop any <i>ACR</i> current flow through the point of work and the <i>Neutral Conductor</i> as a result of earths on the rail operators system.

NOTES FOR CONFIGURATION H

Note 1 – Earth Continuity Conductor (ECC)

The ECC installed with each power cable circuit is connected both to Oxenholme 25kv substation earth and the furthest joint bay containing link equipment. The ECC will therefore carry a measure of ACR current under all load conditions (single or double circuit operation). If it is necessary to cut or joint the conductor of the ECC then this should only be performed on the ECC of a circuit which has been de-energised and any repairs may be performed taking the precautions given in this document, NSI 24 and NSI 5.

Note 2 – Radial Earth

Two radial earth bare conductors are connected to the Oxenholme 25kv earth mat. These radial earths run out of the substation perimeter and are installed parallel to, but separately from, the 25kV power cable system with one bare earth conductor installed in separate trenches either side of the power cable circuits. The two radial earth conductors are connected together at their furthest extent and form a single loop. As measured from Oxenholme 25kv substation, the radial earth conductors cross beneath the power cable system at approximately the 500m and 1000m distance (this is required to reduce induced circulating current) and also at the loop connection 1270m position.

For a more accurate position of the crossing points the reader is referred to the 25kV power cable circuit route records. When working on one of the power cable circuits the use of the bare radial earth conductor as an earth is not permitted as this may allow a circulating current (e.g. via the power cable system ECC).

If it is necessary to earth a cable conductor or sheath in AREA 3G then a local earth mat and rods should be installed (see the example in the diagram below) and, if exposed or in danger of being exposed, the radial earth shall be insulated through the work area (for example by the use of a split polythene pipe or earth mat covering). Any handling or repairs to a radial earth conductor must be performed whilst isolated from the power cable system and in accordance with the requirements of NSI 24.

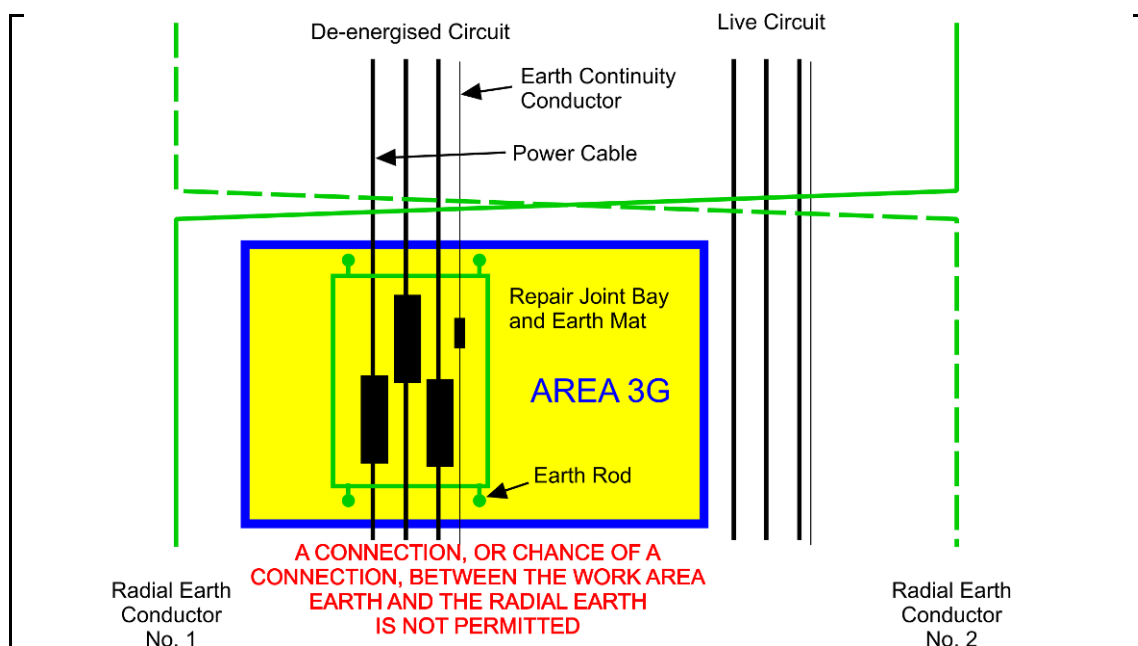
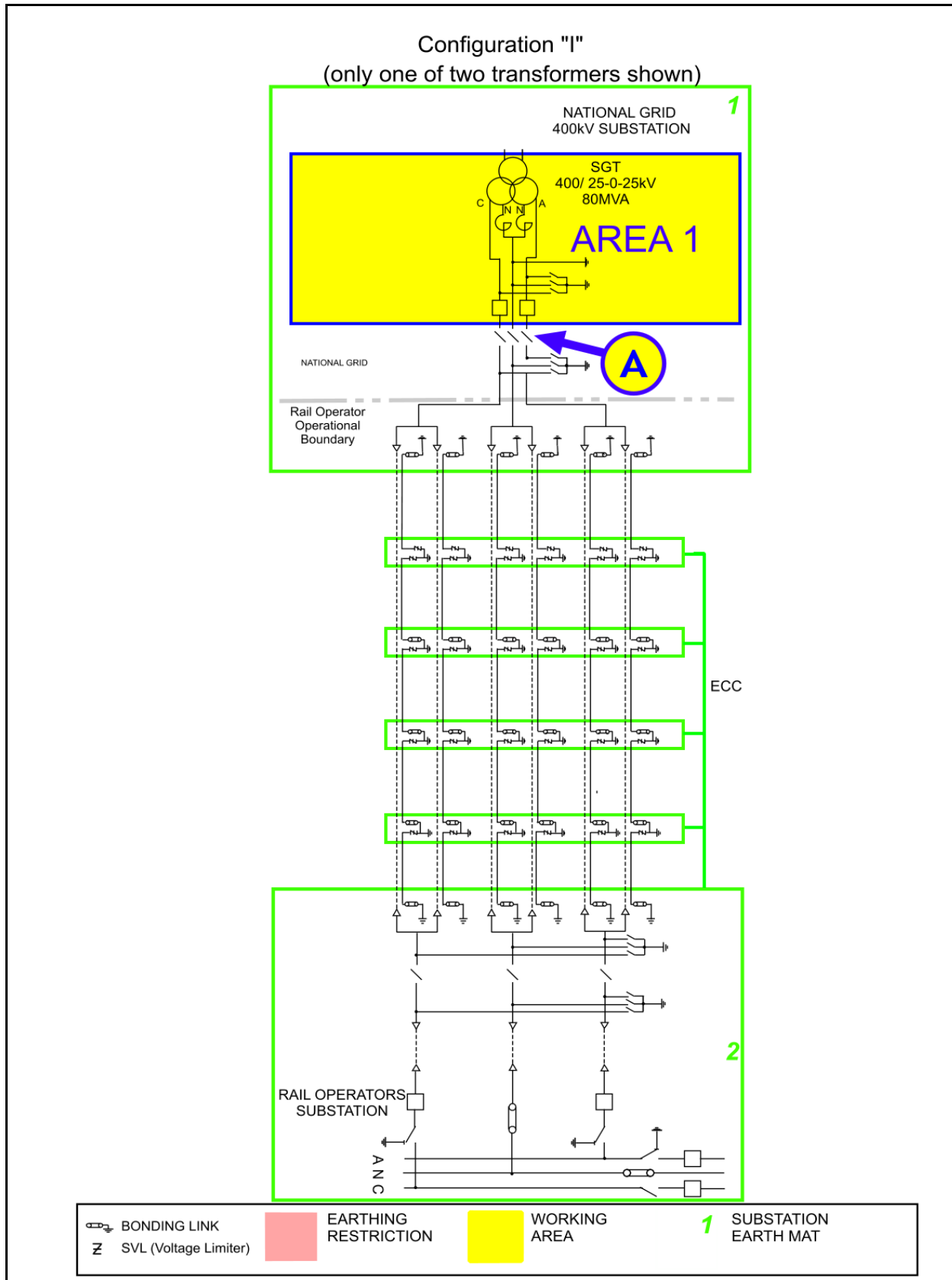

Figure H – Working Near Radial Earth Conductors

This page has been left Blank

CONFIGURATION I
CONFIGURATION I – AREA 1



The following table is not a switching sequence. A **Senior Authorised Person** shall include the following tabulated precautions required on **Equipment** as part of a switching, isolating and earthing sequence to eliminate *ACR Current* from the designated working AREA.

AREA 1

Equipment	Precautions Required	Reason
Disconnecter A	Check open, lock and apply the "Do Not Close Notice"	To prevent any <i>ACR Current</i> from finding a return path through the work area.

CONFIGURATION 1 – AREA 2

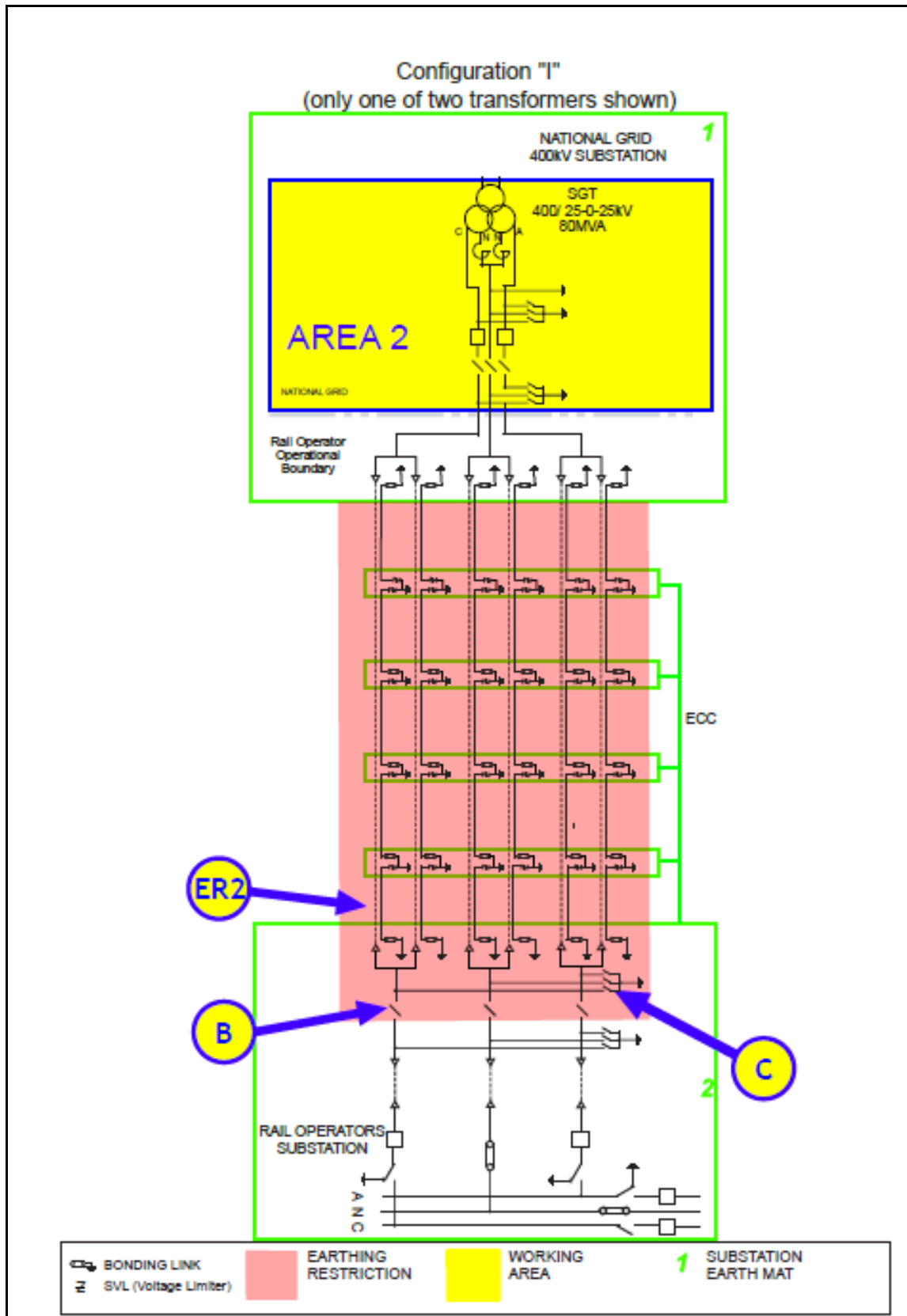

The following table is not a switching sequence. A **Senior Authorised Person** shall include the following tabulated precautions required on **Equipment** as part of a switching, isolating and earthing sequence to eliminate *ACR Current* from the designated working AREA.

AREA 2A

Equipment	Precautions Required	Reason
Disconnectors B	NR to ensure that this remains Open	Disconnect conductors from 25kV substation and rail operators System to stop <i>ACR Current</i> between earth mats via the pole and <i>Neutral Conductors</i> .
Earth Switch C	NR to ensure that this remains Open	This precaution is necessary, as an earth on any of the Poles or <i>Neutral Conductor</i> will create a parallel path through which <i>ACR Current</i> will flow.
Earth restriction zone ER2	NR to ensure that no earths are applied on Equipment inside region ER2.	This precaution is necessary, as an earth on any of the Poles, <i>Neutral Conductor</i> or Cable Sheath will create a parallel path through which <i>ACR Current</i> will flow.

For multiple work locations on cables or their accessories refer to section 8.1 of this document.

CONFIGURATION J
CONFIGURATION J – AREA 18

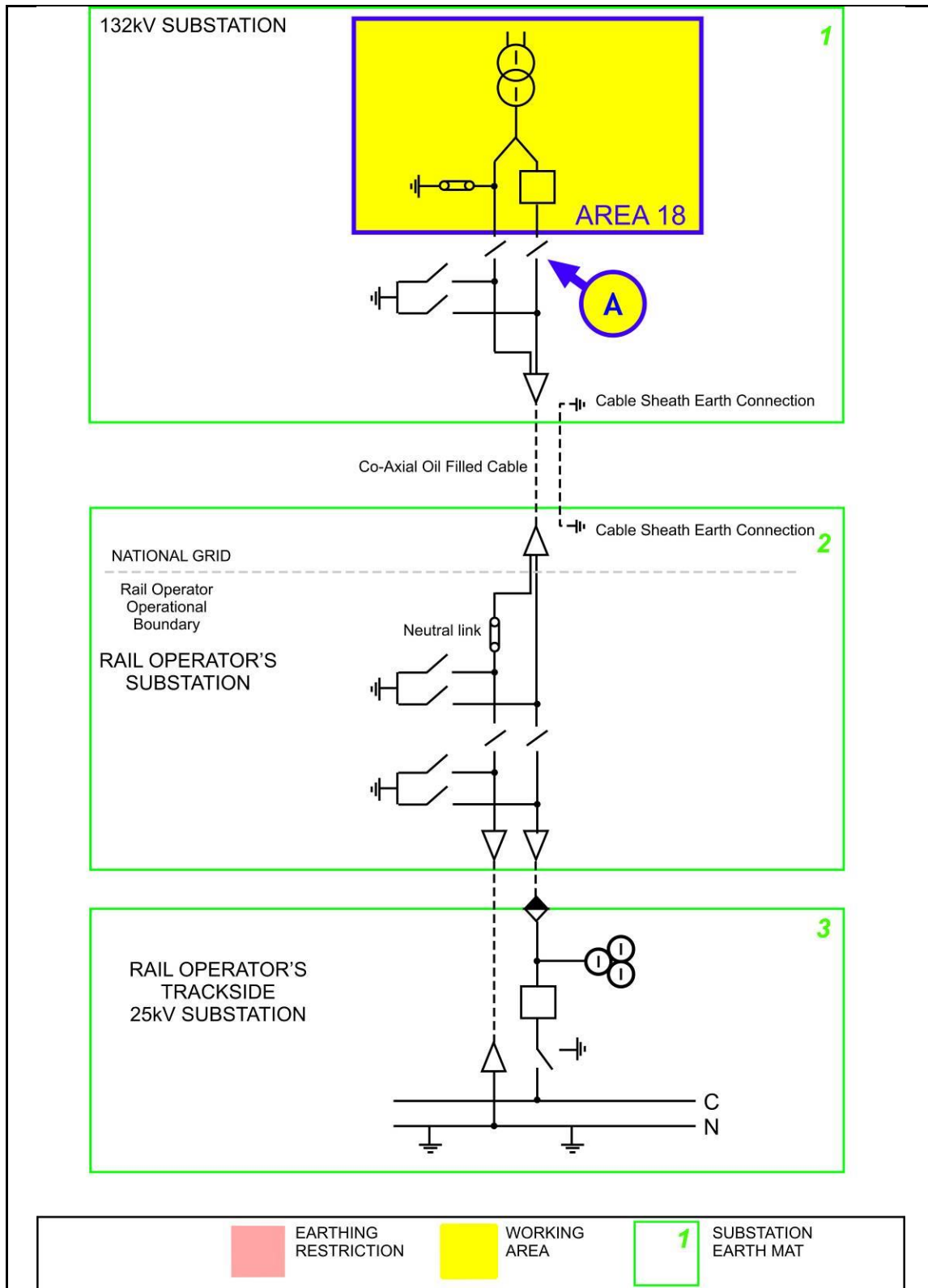

The following table is not a switching sequence. A **Senior Authorised Person** shall include the following tabulated precautions on **Equipment** as part of a switching, isolating and earthing sequence to eliminate *ACR Current* from the designated working AREA.

AREA 18

Equipment	Precautions Required	Reason
Disconnect A	Check open, lock and apply the "Do Not Close Notice"	To prevent ACR Current from finding a return path through the work area.

Note: Both Pole and Neutral conductors are contained within a single oil filled cable. The cable includes a central 25kV Pole Conductor, concentric Neutral Conductor and a concentric outer metallic (lead) sheath. The lead sheath is solidly bonded to the substation earth mats at each end via a bolted connections (without cable sheath links) onto the substation earth mat.

Note: Where conductors, metallic sheaths or armour wires of light current cables connect separate earth mats, then these connections shall only be broken or remade when all railway supply transformers on these earth mats are de-energised. This precaution is not required if it can be shown that there are no **Dangers** arising from the disconnection or reconnection of light current cabling earth mat interconnections.

CONFIGURATION J – AREA 19 AND AREA 19B

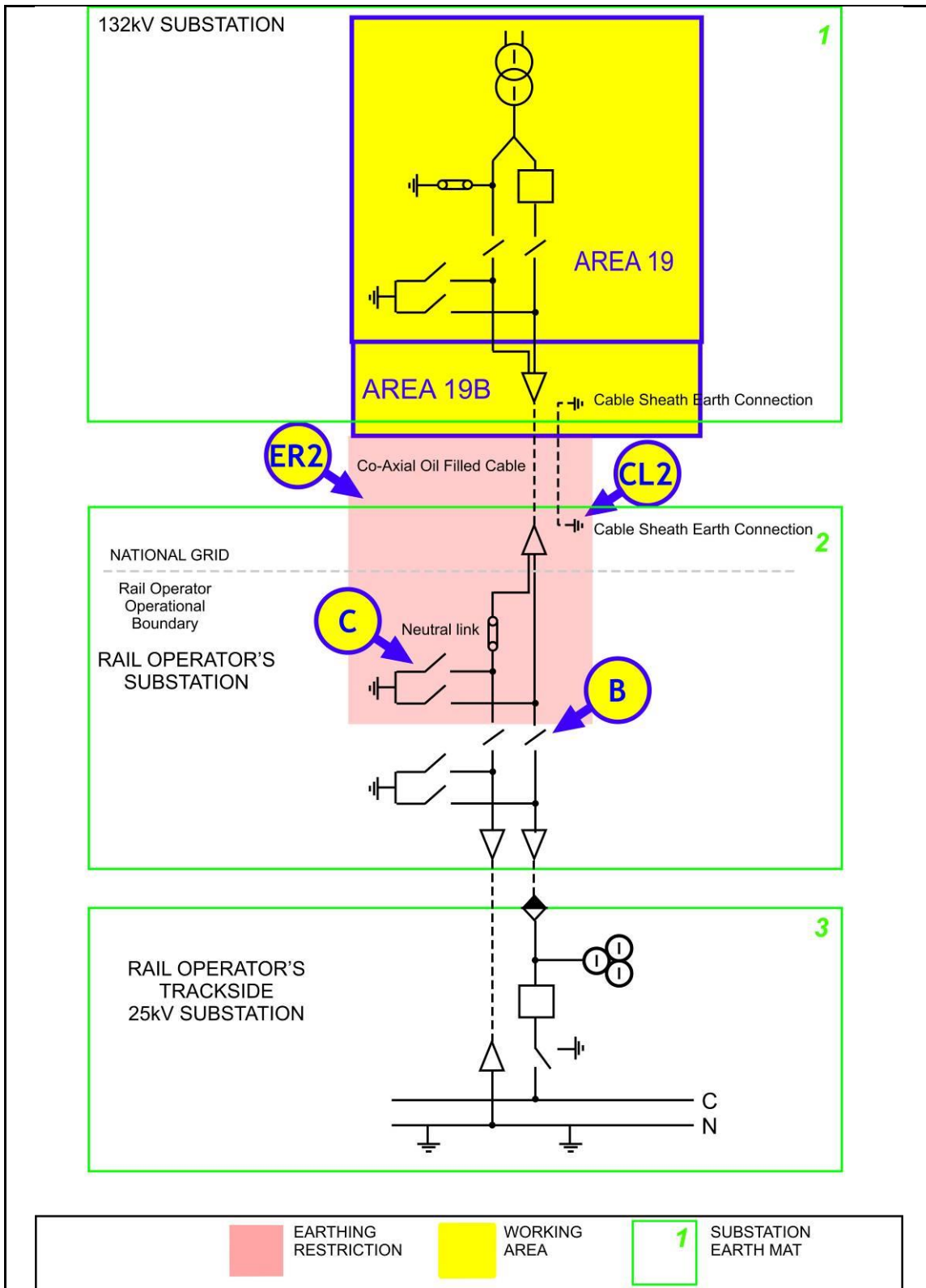

The following table is not a switching sequence. A **Senior Authorised Person** shall include the following tabulated precautions on **Equipment** as part of a switching, isolating and earthing sequence to eliminate *ACR Current* from the designated working AREA.

AREA 19

Equipment	Precautions Required	Reason
Disconnect B	Check open, lock and apply the "Do Not Close Notice"	Disconnect conductors from 25kV substations and Rail Operator's System to stop <i>ACR Current</i> between earth mats via the <i>Pole</i> and <i>Neutral Conductor</i>
Earth Switch C	Open Earth Switch C and apply the "Do Not Earth Conductors Notice"	This precaution is necessary, as an earth on the <i>Pole</i> or <i>Neutral Conductor</i> will create a parallel path through which <i>ACR Current</i> will flow
Earth Restriction Zone ER2	Do not apply earth(s) on Equipment inside region ER2.	This precaution is necessary, as an earth on the <i>Pole</i> , <i>Neutral Conductor</i> or Cable Sheath will create a parallel path through which <i>ACR Current</i> will flow.

AREA 19B

If works are required on, or that could infringe a **Safety Distance** to, the cables, cable sealing ends, oil pipe insulator or cable sheath connections then the following additional requirement to those for AREA 19 applies.

Cable sheath earth connection, CL2.	Remove the cable sheath earth connection from the termination and apply the "Do Not Earth Conductors Notice". Removal and reconnection shall only be performed when all railway supply transformers on the connected earth mats are de-energised.	WARNING! THE CABLE SHEATH CONNECTIONS SHALL NEVER BE REMOVED OR REPLACED WITHOUT A DOUBLE CIRCUIT OUTAGE. The reason for this is that they solidly bond the earth mats providing an earth return path. As a result there is always the possibility of significant <i>ACR Currents</i> flowing through this connections. During the double circuit outage a cable sheath test should be carried out to ensure its integrity prior to relying on the removal of the links as an <i>ACR</i> precaution and returning the operational circuit back into service.
-------------------------------------	---	---

For guidance on the use of AREA 19B or AREA 20 refer to section 4.3 of this document.

For multiple work locations on cables or their accessories refer to section 8.1 of this document.

Note: Where conductors, metallic sheaths or armour wires of light current cables connect separate earth mats, then these connections shall only be broken or remade when all railway supply transformers on these earth mats are de-energised. This precaution is not required if it can be shown that there are no **Dangers** arising from the disconnection or reconnection of light current cabling earth mat interconnections.

CONFIGURATION J – AREA 20

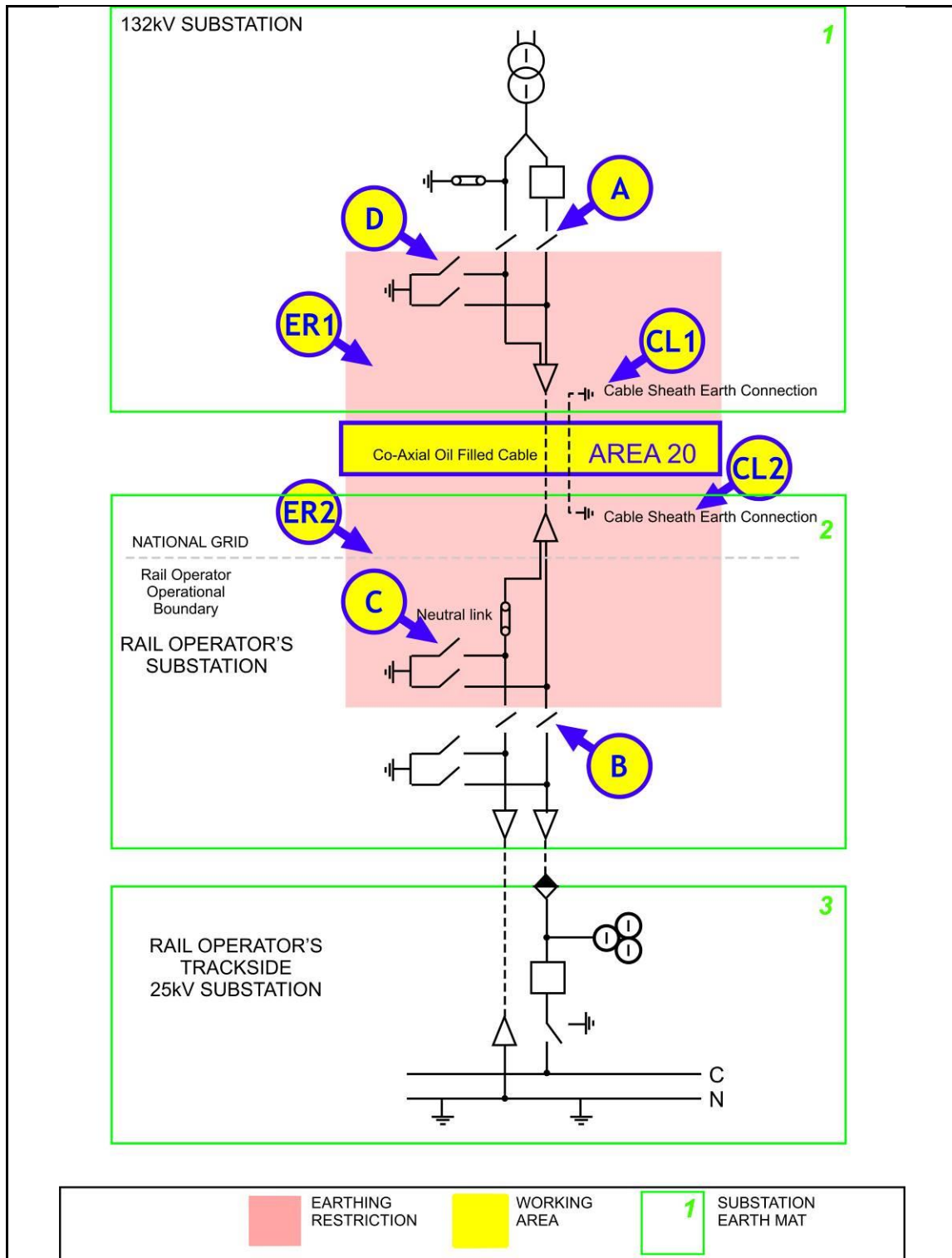

The following table is not a switching sequence. A **Senior Authorised Person** shall include the following tabulated precautions on **Equipment** as part of a switching, isolating and earthing sequence to eliminate *ACR Current* from the designated working AREA.

AREA 20

Equipment	Precautions Required	Reason
Disconnectors A and B	Check open, lock and apply the "Do Not Earth Conductors Notice"	Avoid <i>ACR Current</i> in conductors between the 25kV and 132kV substations from the Rail Operators System .
Earth Switches C and D	Open Earth Switches and apply the "Do Not Earth Conductors Notice".	This precaution is necessary to prevent <i>ACR Current</i> flowing along the cable and through the mass of earth when an earth is placed on a cable conductor or sheath in AREA 20
<i>Earthing restriction zones</i> ER1 and ER2.	Do not apply earths on Equipment inside regions ER1 or ER2.	This precaution is necessary to prevent <i>ACR Current</i> flowing along the cable and through the mass of earth when an earth is placed on a cable conductor or sheath in AREA 20. The placing of an earth in the restricted regions ER1 or ER2 would create an alternative path for <i>ACR Current</i> (s).
Cable sheath earth connections, CL1 and CL2.	Remove the cable sheath earth connections from the terminations and apply the "Do Not Earth Conductors Notice". Removal and reconnections shall only be performed when all railway supply transformers on the connected earth mats are de-energised.	WARNING! THE CABLE SHEATH CONNECTIONS SHALL NEVER BE REMOVED OR REPLACED WITHOUT A DOUBLE CIRCUIT OUTAGE. The reason for this is that they solidly bond the earth mats providing an earth return path. As a result there is always the possibility of significant <i>ACR Currents</i> flowing through this connections. During the double circuit outage a cable sheath test should be carried out to ensure its integrity prior to relying on the removal of the links as an <i>ACR</i> precaution and returning the operational circuit back into service.

For guidance on the use of AREA 19B, AREA 21B or AREA 3 refer to Section 4.3 of this document.

For multiple work locations on cables or their accessories refer to section 8.1 of this document.

Note: Where conductors, metallic sheaths or armour wires of light current cables connect separate earth mats, then these connections shall only be broken or remade when all railway supply transformers on these earth mats are de-energised. This precaution is not required if it can be shown that there are no **Dangers** arising from the disconnection or reconnection of light current cabling earth mat interconnections.

CONFIGURATION J – AREA 21B

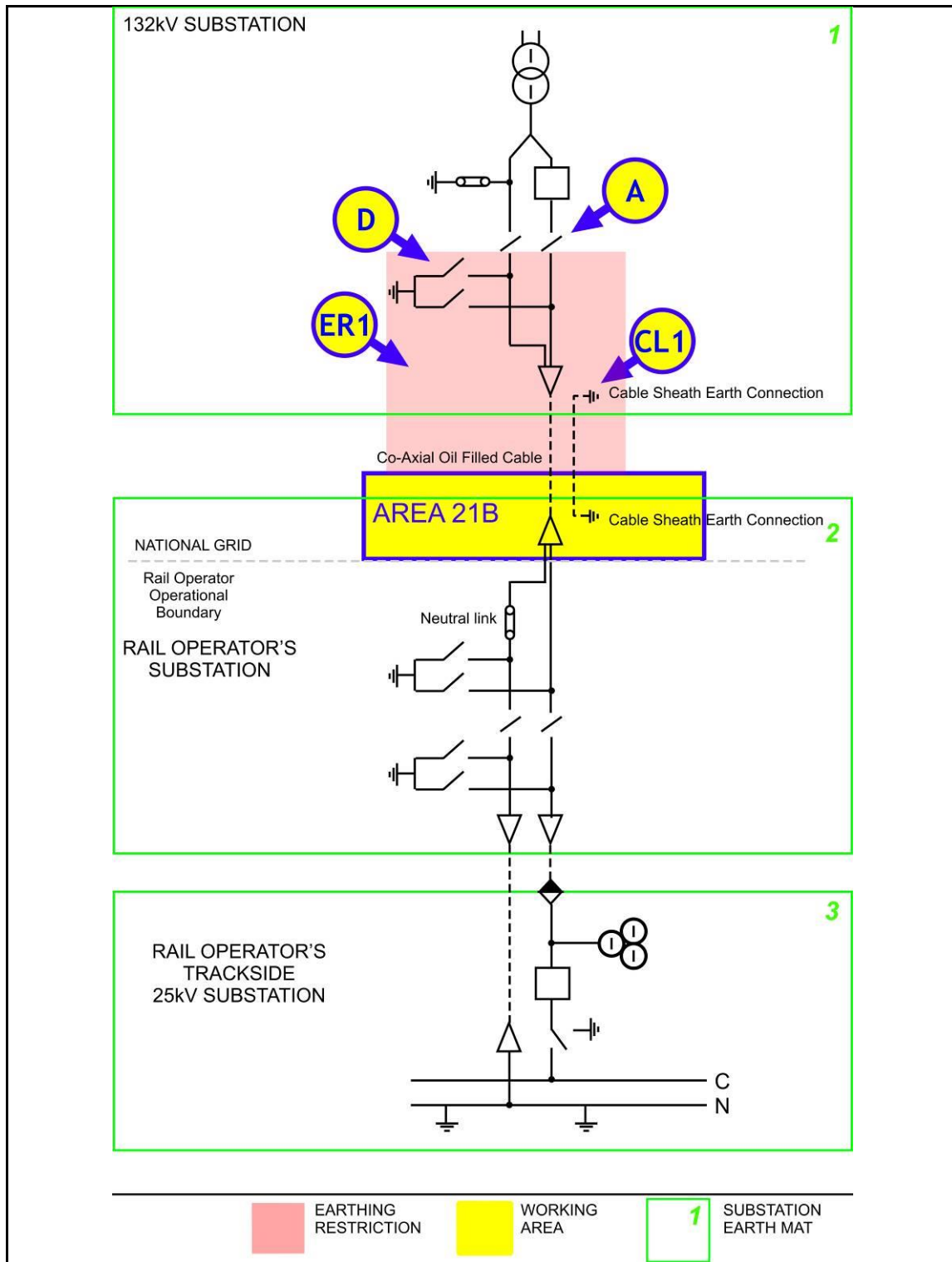

The following table is not a switching sequence. A **Senior Authorised Person** shall include the following tabulated precautions on **Equipment** as part of a switching, isolating and earthing sequence to eliminate *ACR Current* from the designated working AREA.
AREA 21B

Equipment	Precautions Required	Reason
Disconnecter A	Check open, lock and apply the "Do Not Close Notice".	Disconnect conductors from 25kV substation and Rail Operators system and stop <i>ACR Current</i> between earth mats, via the pole and Neutral Conductors, find a return path through the transformer earth.
Earth Switch D	Open Earth Switch D and apply the "Do Not Earth Conductors Notice".	This precaution is necessary to prevent <i>ACR Current</i> flowing along conductors if an earth is placed on a conductor, which would create a parallel path for <i>ACR Current(s)</i> .
Earthing Restriction Zone ER1	Do not apply earths on Equipment inside region ER1.	This precaution is necessary to prevent <i>ACR Current</i> flowing along conductors if an earth is placed on a conductor, which would create a parallel path for <i>ACR Current(s)</i> .
Cable sheath earth connection, CL1.	Remove the cable sheath earth connection from the termination and apply the "Do Not Earth Conductors Notice". Removal and reconnection shall only be performed when all railway supply transformers on the connected earth mats are de-energised.	The cable termination earth connection is to be removed as it is connected to the cable's outer lead sheath and will carry <i>ACR Current</i> during the operation of any railway connection supply transformer. Additional precautions may be necessary to avoid the Dangers of impressed voltages (NSI 5). The links must be reinstalled before the circuit is energised.

For guidance on the use of AREA 21B or AREA 20 refer to section 4.3 of this document.

For multiple work locations on cables or their accessories refer to section 8.1 of this document.

Note: Where conductors, metallic sheaths or armour wires of light current cables connect separate earth mats, then these connections shall only be broken or remade when all railway supply transformers on these earth mats are de-energised. This precaution is not required if it can be shown that there are no **Dangers** arising from the disconnection or reconnection of light current cabling earth mat interconnections.

CONFIGURATION K
CONFIGURATION K – AREA 1

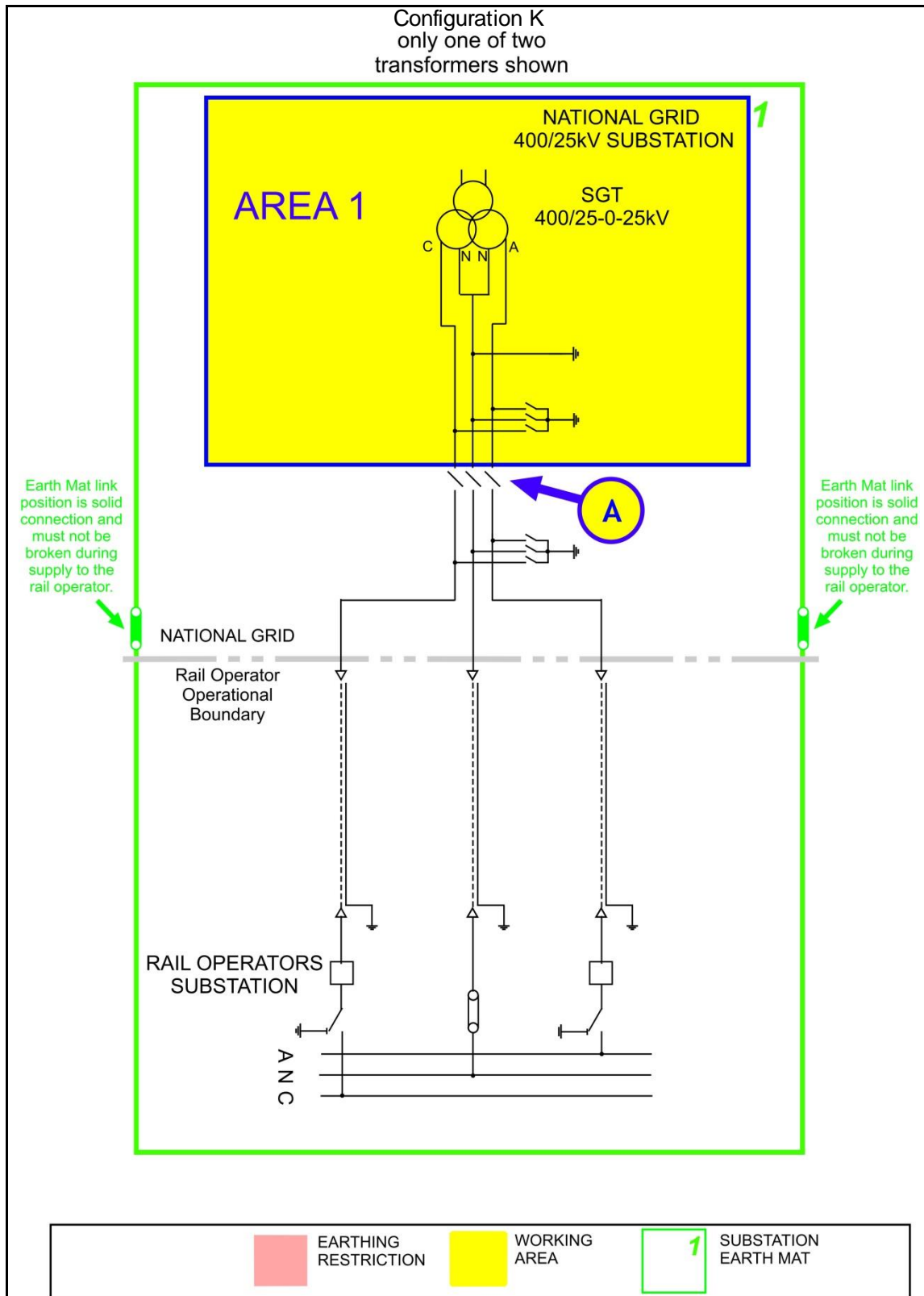

The following table is not a switching sequence. A **Senior Authorised Person** shall include the following tabulated precautions on **Equipment** as part of a switching, isolating and earthing sequence to eliminate *ACR Current* from the designated working AREA.

AREA 1

Equipment	Precautions Required	Reason
Disconnect A	Check open, lock and apply the "Do Not Close Notice"	Disconnect conductors connected to the Rail Operator's System to stop <i>ACR Current</i> flowing through the point of work via the <i>Pole</i> and <i>Neutral Conductors</i> .

NOTE: The earth mat links connecting the National Grid's earth mat to the Rail Operator's earth mat must not be removed during the operation of any supplying transformer.

CONFIGURATION K – AREA 2

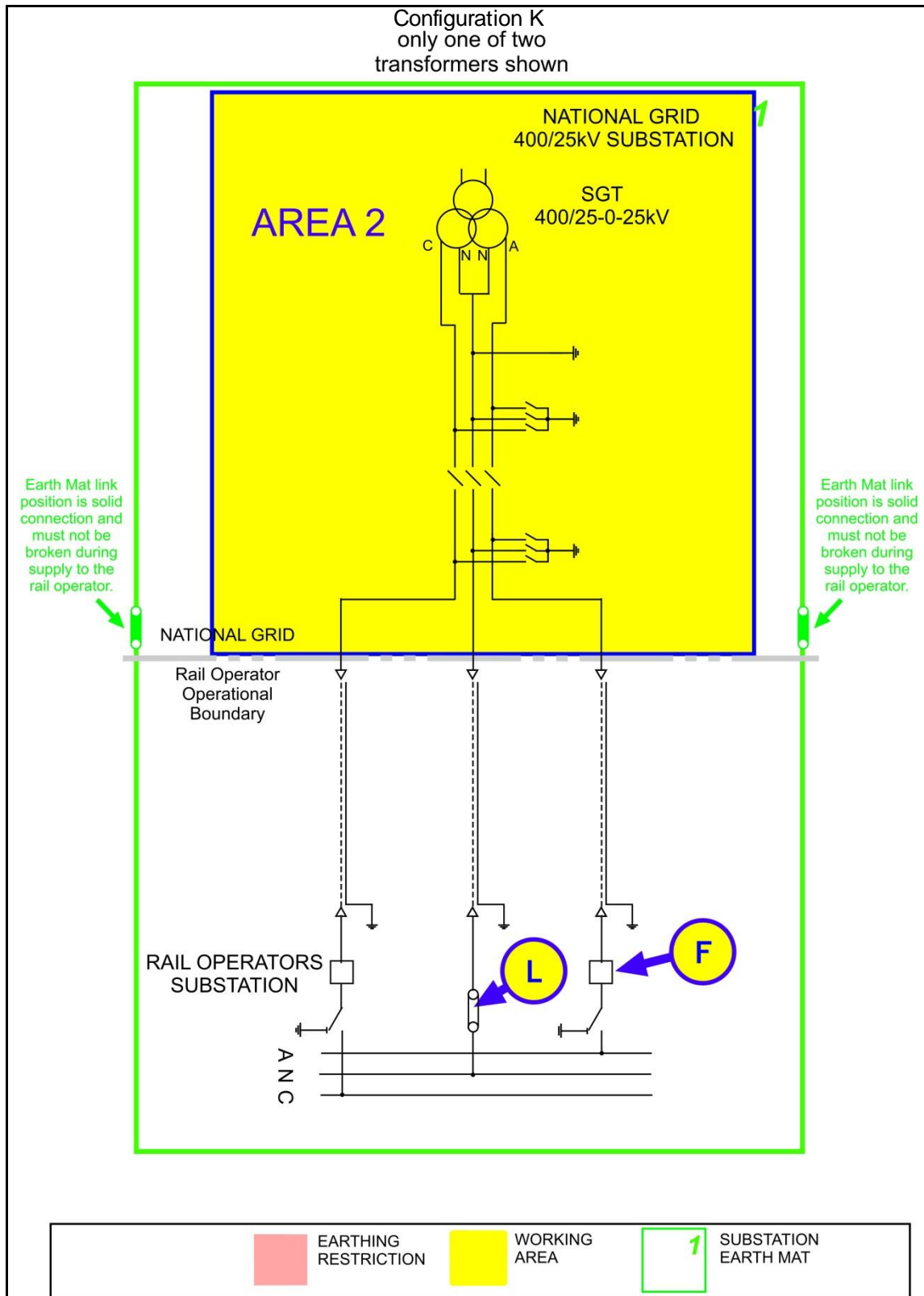

The following table is not a switching sequence. A **Senior Authorised Person** shall include the following tabulated precautions on **Equipment** as part of a switching, isolating and earthing sequence to eliminate *ACR Current* from the designated working AREA.

AREA 2

Equipment	Precautions Required	Reason
Rail Operators Equipment Link L.	Remove Rail Operators neutral link.	To stop any <i>ACR current</i> flow through the point of work via the <i>Neutral Conductor</i> .
Rail Operators Equipment Breaker F	Locked open	To stop and <i>ACR current</i> flowing through the point of work via the <i>C and A poles</i> .

NOTE: The earth mat links connecting the National Grid's earth mat to the Rail Operator's earth mat must not be removed during the operation of any supplying transformer.

CONFIGURATION L

CONFIGURATION L – AREA 1

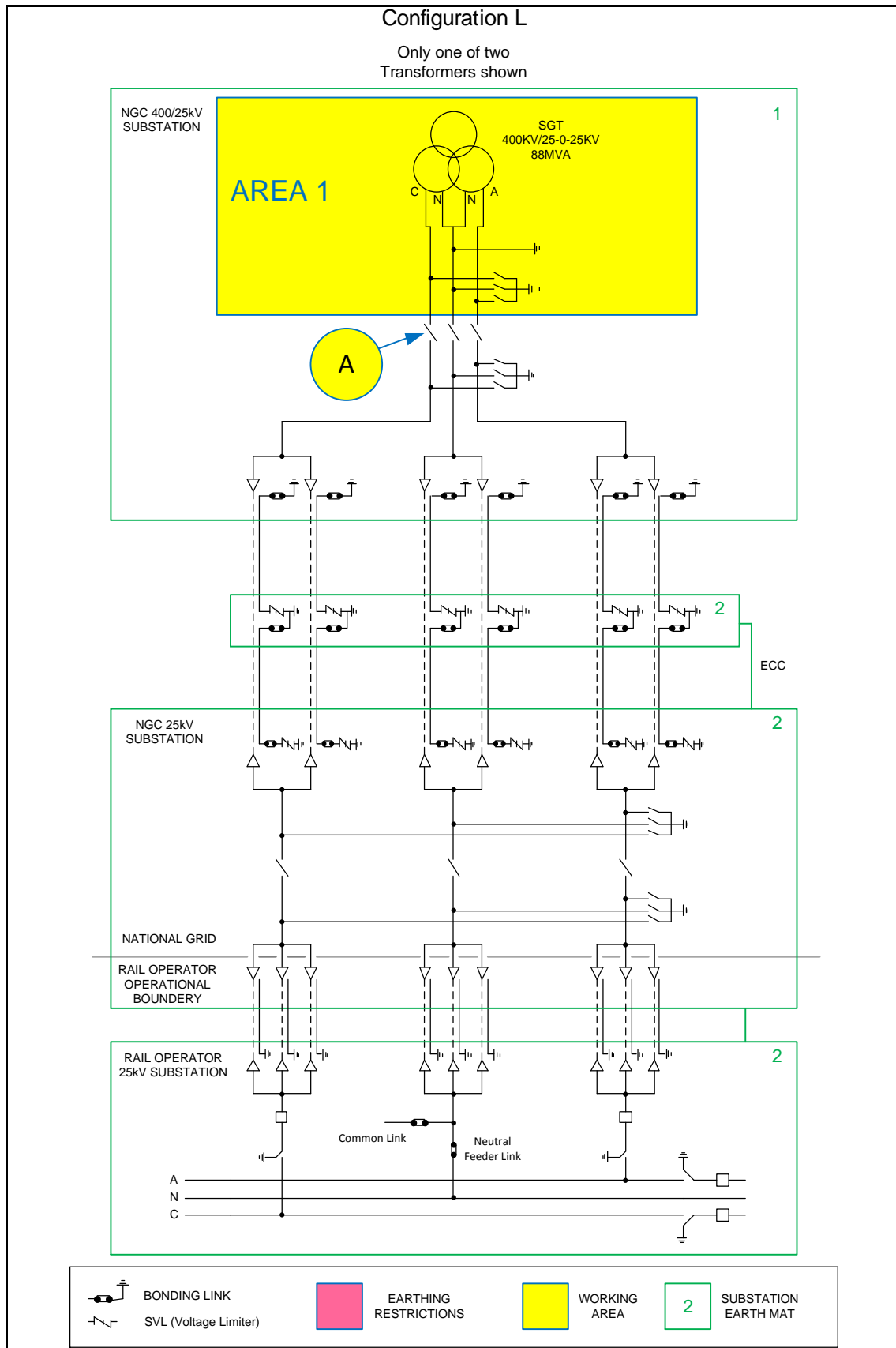

The following table is not a switching sequence. A **Senior Authorised Person** shall include the following tabulated precautions on **Equipment** as part of a switching, isolating and earthing sequence to eliminate *ACR Current* from the designated working AREA.

AREA 1

Equipment	Precautions Required	Reason
Disconnecter A	Check open, lock and apply the "Do Not Close Notice"	To prevent <i>ACR Current</i> from finding a return path through the work area.

CONFIGURATION L – AREA 2A AND 2B

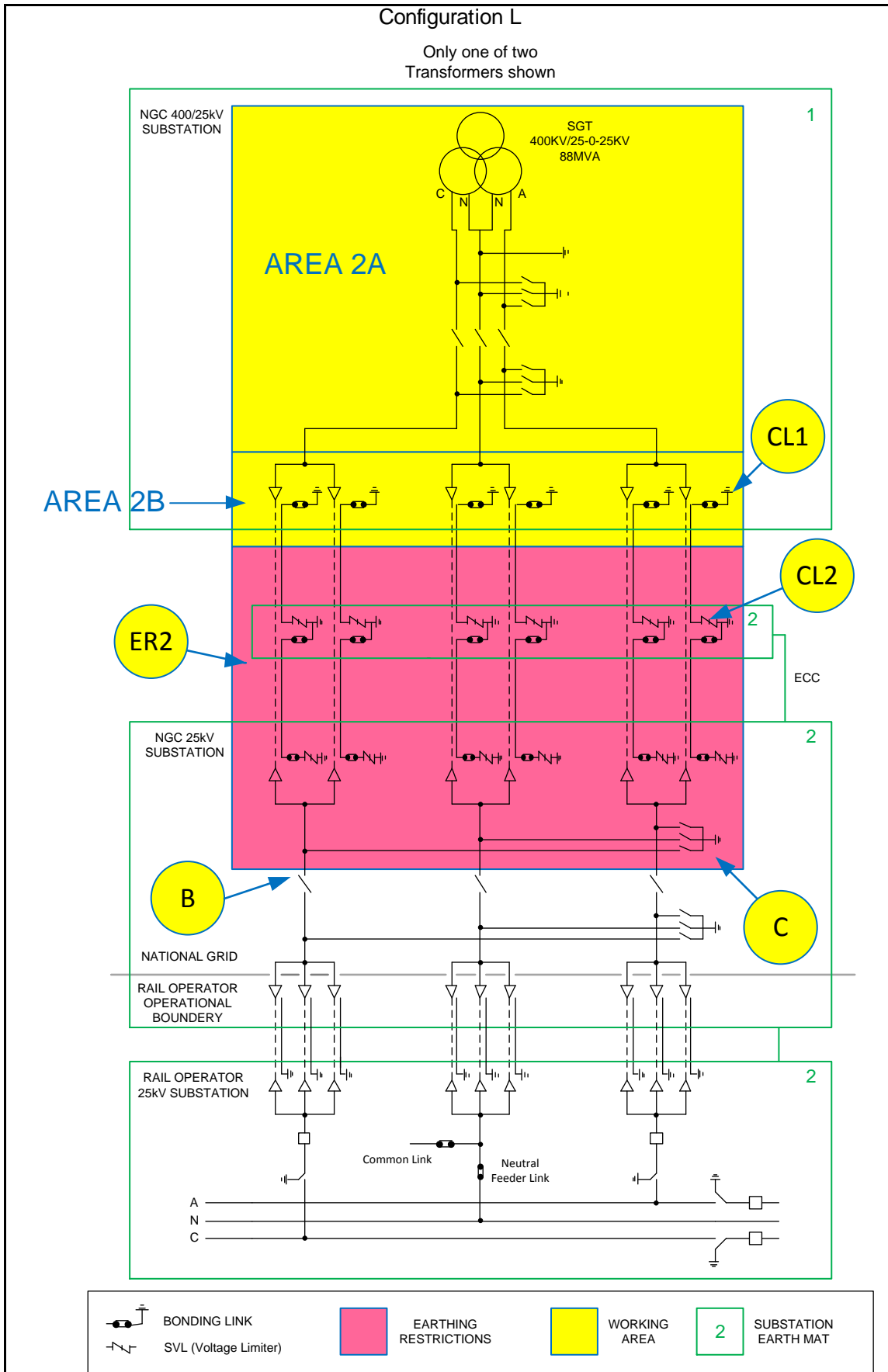

The following table is not a switching sequence. A **Senior Authorised Person** shall include the following tabulated precautions on **Equipment** as part of a switching, isolating and earthing sequence to eliminate *ACR Current* from the designated working AREA.

AREA 2A

Equipment	Precautions Required	Reason
Disconnect B	Check open, lock and apply the "Do Not Close Notice"	Disconnect conductors from 25kV substation and Rail Operators System to stop <i>ACR Current</i> between earth mats via the <i>Poles</i> and <i>Neutral Conductors</i> .
Earth Switch C	Open Earth Switch and apply the "Do Not Earth Conductors Notice"	This precaution is necessary as an earth on any of the <i>Poles</i> or <i>Neutral Conductor</i> will create a parallel path through which <i>ACR Current</i> will flow.
Earth restriction region ER2	Do not apply earths on Equipment inside region ER2.	This precaution is necessary, as an earth on any of the <i>Poles</i> , <i>Neutral Conductor</i> or cable sheath will create a parallel path through which <i>ACR Current</i> will flow.

AREA 2B

If works are required on, or that could infringe the **Safety Distance** to, the cables, cable sealing ends or cable sheath connections then the following additional requirement to those for AREA 2A applies.

Equipment	Precautions Required	Reason
Cable sheath SVLs, CL2	Remove the sheath voltage limiter in accordance with the principles of NSI 5. Apply the "Do Not Earth Conductors Notice"	These links are to be removed in case the SVLs are not operating correctly. Removal of the links from all cables will prevent <i>ACR Current</i> flowing between the earth mats along the cable sheaths. NOTE: The cable bonding links "CL1" at the solidly bonded position shall be removed prior to removing / replacing the links "CL2" at an SVL position. "CL1" shall not be quoted as an <i>ACR</i> precaution.

For guidance on the use of AREA 2B or AREA 3A refer to section 4.3 of this document.

For multiple work locations on cables or their accessories refer to section 8.1 of this document.

CONFIGURATION L- AREA 3A

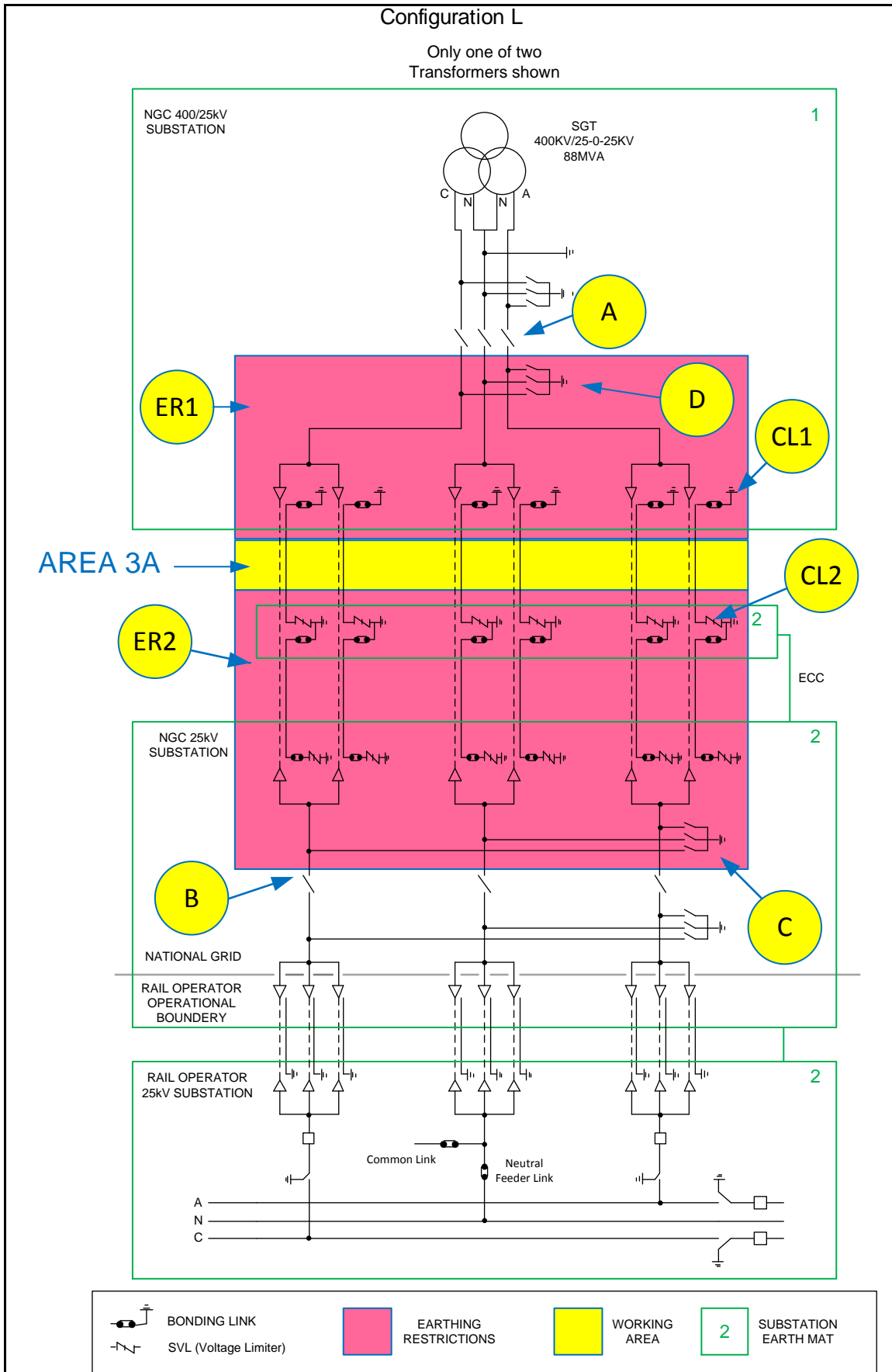

The following table is not a switching sequence. A **Senior Authorised Person** shall include the following tabulated precautions on **Equipment** as part of a switching, isolating and earthing sequence to eliminate *ACR Current* from the designated working AREA.

AREA 3A

Equipment	Precautions Required	Reason
Disconnectors A and B	Check open, lock and apply the "Do Not Close Notice"	Disconnect conductors from 25kV substation and Rail Operators System to stop <i>ACR Current</i> between earth mats via the <i>Poles and Neutral Conductors</i> .
Earth Switches C and D	Open Earth Switch and apply the "Do Not Earth Conductors Notice"	This precaution is necessary to prevent <i>ACR Current</i> flowing along the cable and through the mass of earth when an earth is placed on a cable conductor or sheath in the work area.
Earth restriction region ER1 and ER2	Do not apply earths on Equipment inside regions ER1 or ER2.	This precaution is necessary to prevent <i>ACR Current</i> flowing along the cable and through the mass of earth when an earth is placed on a cable conductor or sheath in the work area. The placing of an earth in the restricted region(s) would create an alternative path for <i>ACR Currents</i> .
Cable sheath bonding links CL1	Remove cable sheath earth and bonding links. Apply the "Do Not Earth Conductors Notice".	These links are to be removed in case the SVLs are not operating correctly. Removal of the links from all cables will prevent <i>ACR Current</i> flowing between the earth mats along the cable sheaths.
Cable sheath SVLs, CL2	Remove the sheath voltage limiter in accordance with the principles of NSI 5. Apply the "Do Not Earth Conductors Notice"	These SVLs are removed in case the SVLs are not operating correctly. Removal of the SVLs from all cables will prevent <i>ACR Current</i> flowing between the earth mats along the cable sheaths.

For guidance on the use of AREA 2B or AREA 3A refer to section 4.3 of this document.

For multiple work locations on cables or their accessories refer to section 8.1 of this document.

CONFIGURATION L – AREA 3B

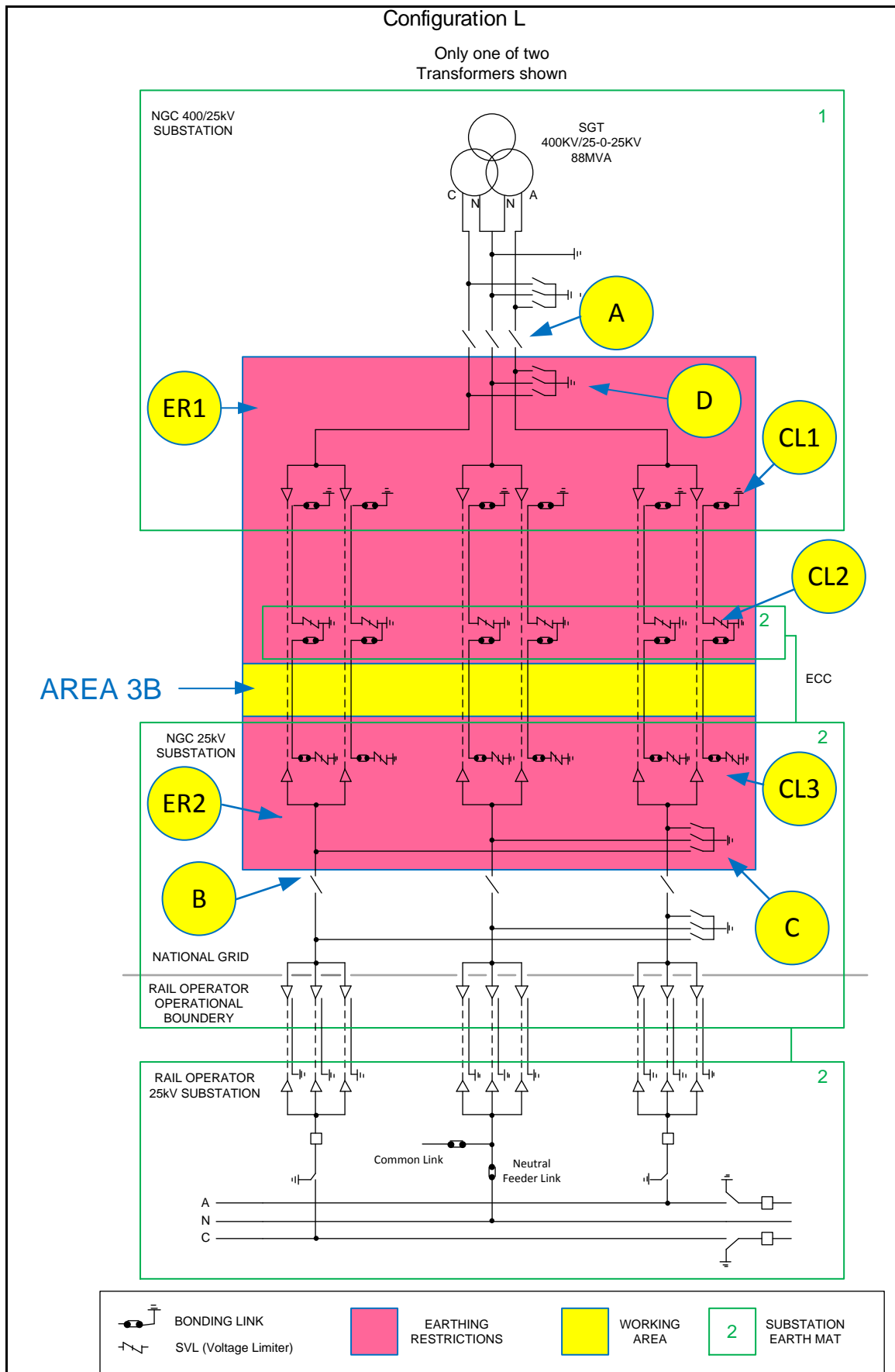

The following table is not a switching sequence. A **Senior Authorised Person** shall include the following tabulated precautions on **Equipment** as part of a switching, isolating and earthing sequence to eliminate *ACR Current* from the designated working AREA.

AREA 3B

Equipment	Precautions Required	Reason
Disconnectors A and B	Check open, lock and apply the "Do Not Close Notice"	Disconnect conductors from 25kV substation and Rail Operators System to stop <i>ACR Current</i> between earth mats via the <i>Poles</i> and <i>Neutral Conductors</i> .
Earth Switches C and D	Open Earth Switch and apply the "Do Not Earth Conductors Notice"	This precaution is necessary to prevent <i>ACR Current</i> flowing along the cable and through the mass of earth when an earth is placed on a cable conductor or sheath in the work area.
Earth restriction region ER1 and ER2	Do not apply earths on Equipment inside regions ER1 or ER2.	This precaution is necessary to prevent <i>ACR Current</i> flowing along the cable and through the mass of earth when an earth is placed on a cable conductor or sheath in the work area. The placing of an earth in the restricted region(s) would create an alternative path for <i>ACR Currents</i> .
Cable sheath bonding links CL1 and CL3	Remove cable sheath earth and bonding links. Apply the "Do Not Earth Conductors Notice".	These links are to be removed in case the SVLs are not operating correctly. Removal of the links from all cables will prevent <i>ACR Current</i> flowing between the earth mats along the cable sheaths.
Cable sheath bonding links CL2	Remove cable sheath earth and bonding links in accordance with NSI5. Apply the "Do Not Earth Conductors Notice".	These links are to be removed in case the SVLs are not operating correctly. Removal of the links from all cables will prevent <i>ACR Current</i> flowing between the earth mats along the cable sheaths.

For guidance on the use of AREA 3B or AREA 17B refer to section 4.3 of this document.

For multiple work locations on cables or their accessories refer to section 8.1 of this document.

CONFIGURATION L- AREA 15

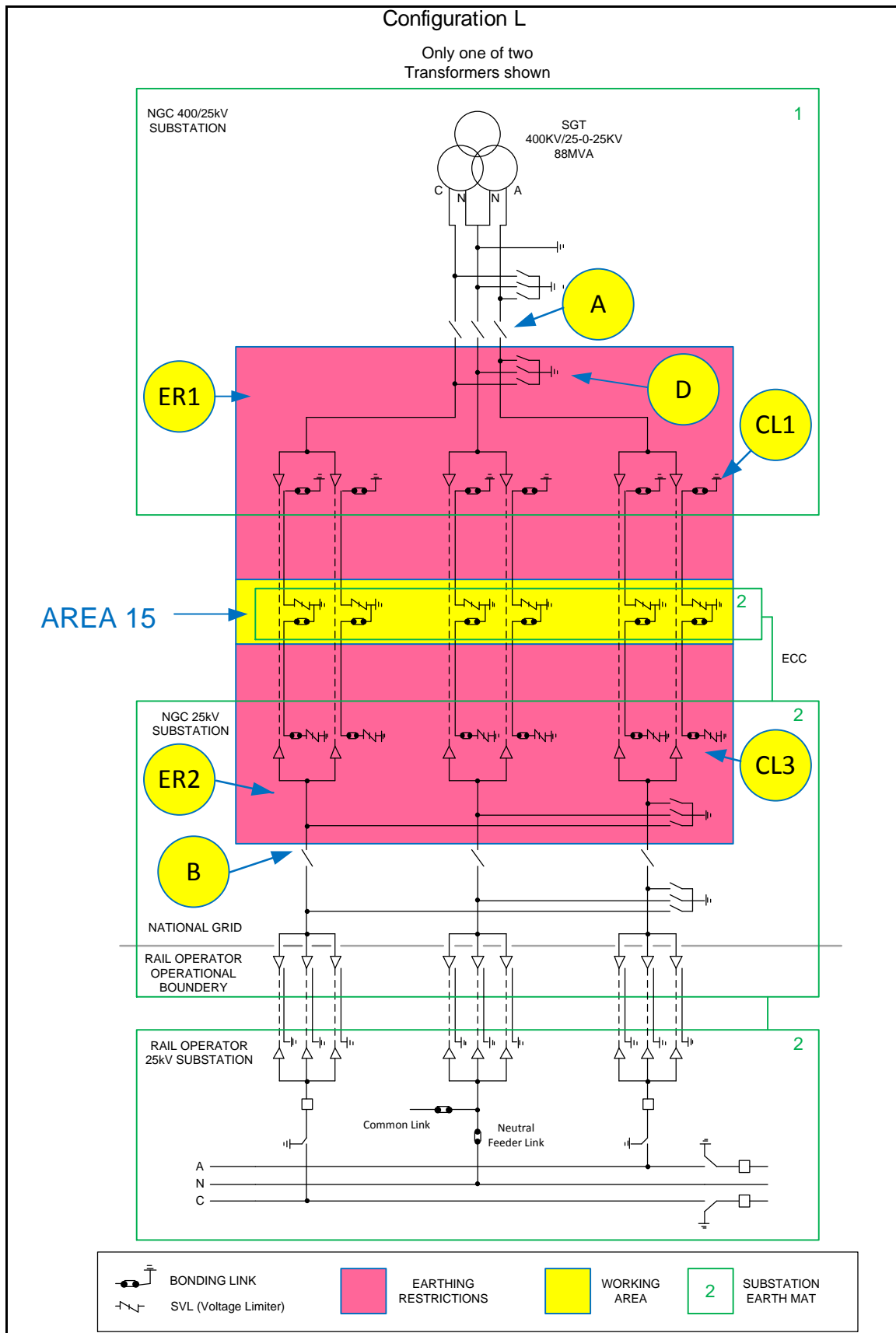

The following table is not a switching sequence. A **Senior Authorised Person** shall include the following tabulated precautions on **Equipment** as part of a switching, isolating and earthing sequence to eliminate *ACR Current* from the designated working AREA.

AREA 15

Equipment	Precautions Required	Reason
Disconnectors A and B	Check open, lock and apply the "Do Not Close Notice"	Disconnect conductors from 25kV substation and Rail Operators System to stop <i>ACR Current</i> between earth mats via the <i>Poles</i> and <i>Neutral Conductors</i> .
Earth Switch D	Open Earth Switch and apply the "Do Not Earth Conductors Notice"	This precaution is necessary to prevent <i>ACR Current</i> flowing along the cable and through the mass of earth when an earth is placed on a cable conductor or sheath in the work area..
Earth restriction region ER1 and ER2	Do not apply earths on Equipment inside regions ER1 or ER2.	This precaution is necessary to prevent <i>ACR Current</i> flowing along the cable and through the mass of earth when an earth is placed on a cable conductor or sheath in the work area. The placing of an earth in the restricted region(s) would create an alternative path for <i>ACR Currents</i> .
Cable sheath bonding links CL1 and CL3	Remove cable sheath earth and bonding links. Apply the "Do Not Earth Conductors Notice".	These links are to be removed in case the SVLs are not operating correctly. Removal of the links from all cables will prevent <i>ACR Current</i> flowing between the earth mats along the cable sheaths.

For guidance on the use of AREA 15 refer to section 4.3 of this document.

For multiple work locations on cables or their accessories refer to section 8.1 of this document.

CONFIGURATION L- AREA 17A AND 17B

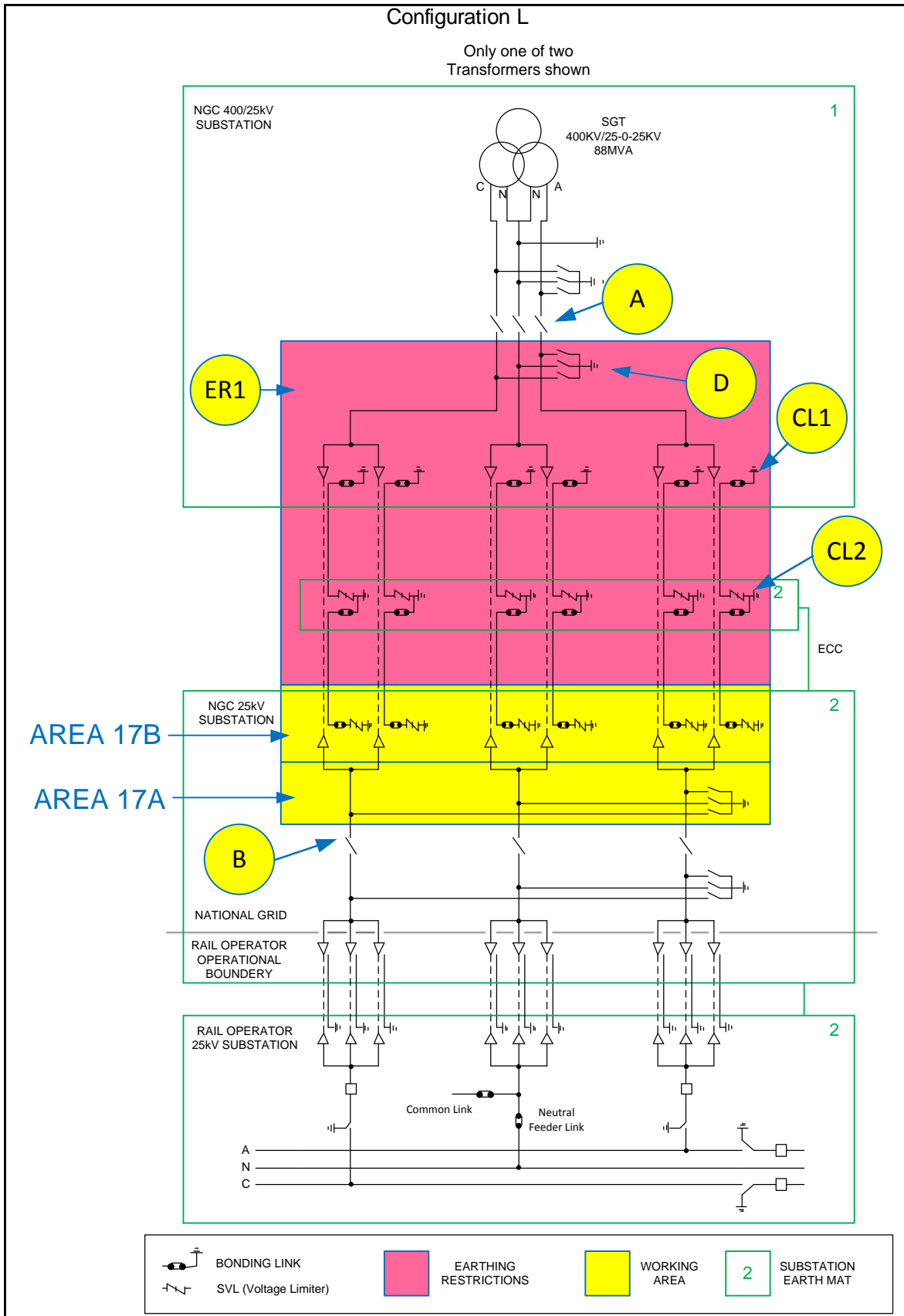

The following table is not a switching sequence. A **Senior Authorised Person** shall include the following tabulated precautions on **Equipment** as part of a switching, isolating and earthing sequence to eliminate *ACR Current* from the designated working AREA.

AREA 17A

Equipment	Precautions Required	Reason
Disconnectors A and B	Check open, lock and apply the "Do Not Close Notice"	Disconnect conductors from 25kV substation and Rail Operators System to stop <i>ACR Current</i> between earth mats via the <i>Poles</i> and <i>Neutral Conductors</i> .
Earth Switch D	Open Earth Switch and apply the "Do Not Earth Conductors Notice"	This precaution is necessary to prevent <i>ACR Current</i> flowing along the cable and through the mass of earth when an earth is placed on a cable conductor or sheath in the work area..
Earth restriction region ER1	Do not apply earths on Equipment inside regions ER1.	This precaution is necessary to prevent <i>ACR Current</i> flowing along the cable and through the mass of earth when an earth is placed on a cable conductor or sheath in the work area. The placing of an earth in the restricted region would create an alternative path for <i>ACR Current(s)</i> .

AREA 17B

If works are required that may infringe **Safety Distance** to, the Cables, Cable sealing ends or Cable Sheath connections then the following additional requirements to those for AREA 17A apply.

Equipment	Precautions Required	Reason
Cable sheath bonding links CL1	Remove cable sheath earth and bonding links. Apply the "Do Not Earth Conductors Notice".	These links are to be removed in case the SVLs are not operating correctly. Removal of the links from all cables will prevent <i>ACR Current</i> flowing between the earth mats along the cable sheaths.
Cable sheath bonding links CL2	Remove cable sheath earth and bonding links in accordance with the requirements of NSI5. Apply the "Do Not Earth Conductors Notice".	These links are to be removed in case the SVLs are not operating correctly. Removal of the links from all cables will prevent <i>ACR Current</i> flowing between the earth mats along the cable sheaths.

For guidance on the use of AREA 17B or AREA 3B refer to section 4.3 of this document.

For multiple work locations on cables or their accessories refer to section 8.1 of this document.

CONFIGURATION L- AREA 18

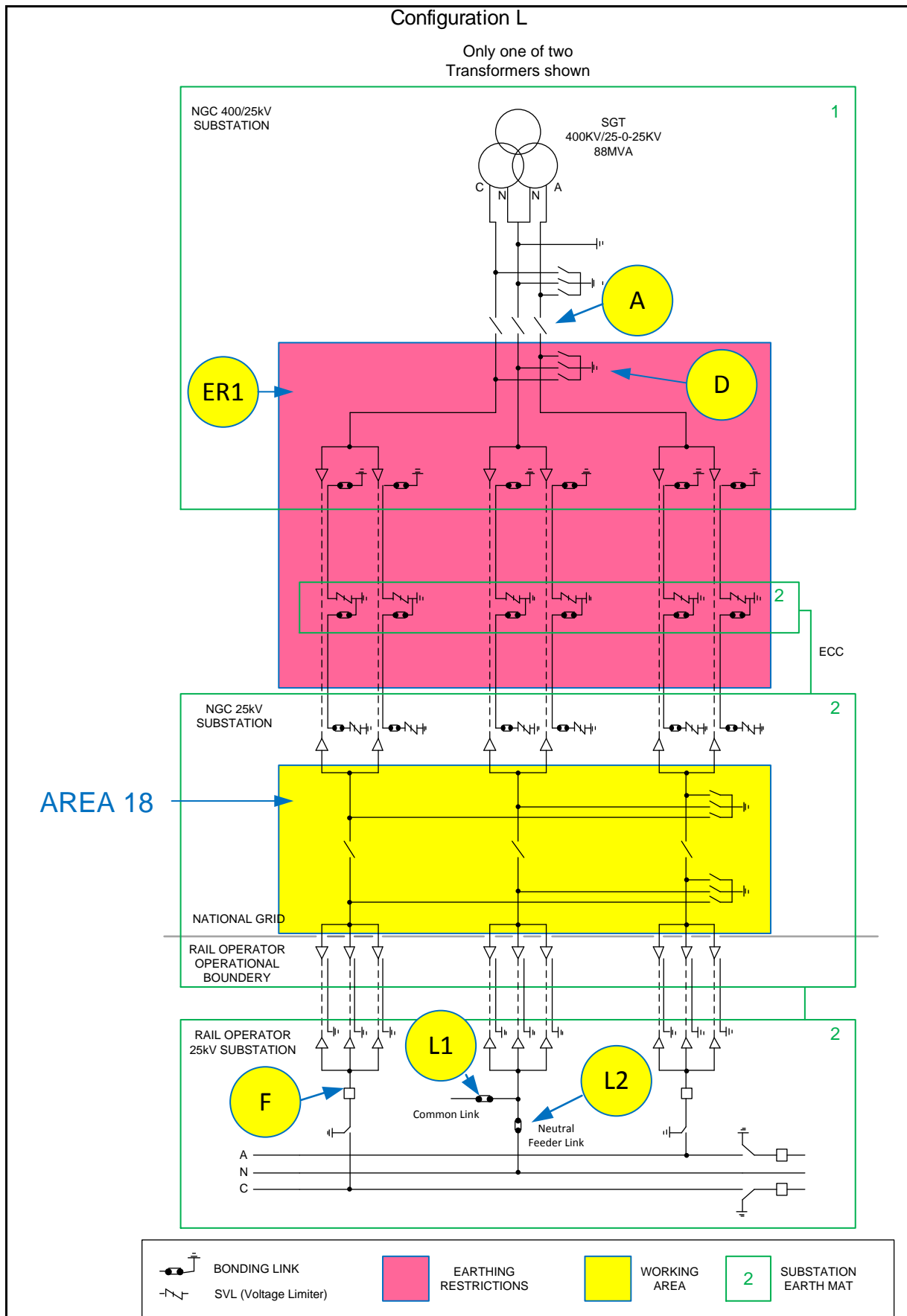

The following table is not a switching sequence. A **Senior Authorised Person** shall include the following tabulated precautions on **Equipment** as part of a switching, isolating and earthing sequence to eliminate *ACR Current* from the designated working AREA.

AREA 18

Equipment	Precautions Required	Reason
Disconnectors A	Check open, lock and apply the "Do Not Close Notice"	Disconnect conductors from 25kV substation and Rail Operators System to stop <i>ACR Current</i> between earth mats via the <i>Poles</i> and <i>Neutral Conductors</i> .
Earth Switch D	Open Earth Switch and apply the "Do Not Earth Conductors Notice"	This precaution is necessary to prevent <i>ACR Current</i> flowing along the cable and through the mass of earth when an earth is placed on a cable conductor or sheath in the work area.
Earth restriction region ER1	Do not apply earths on Equipment inside regions ER1	This precaution is necessary to prevent <i>ACR Current</i> flowing along the cable and through the mass of earth when an earth is placed on a conductor in the work area. The placing of an earth in the restricted region would create an alternative path for <i>ACR Currents</i> .
Rail Operators Equipment Circuit Breaker F	Locked Open.	To stop any <i>ACR Current</i> flow through the work area on the Pole Conductors,
Rail Operators Equipment Links L1 and L2.	Remove Rail Operator neutral links L1 and L2.	To stop any <i>ACR Current</i> through the work area on the Neutral conductor.

CONFIGURATION M CONFIGURATION M – AREA 1

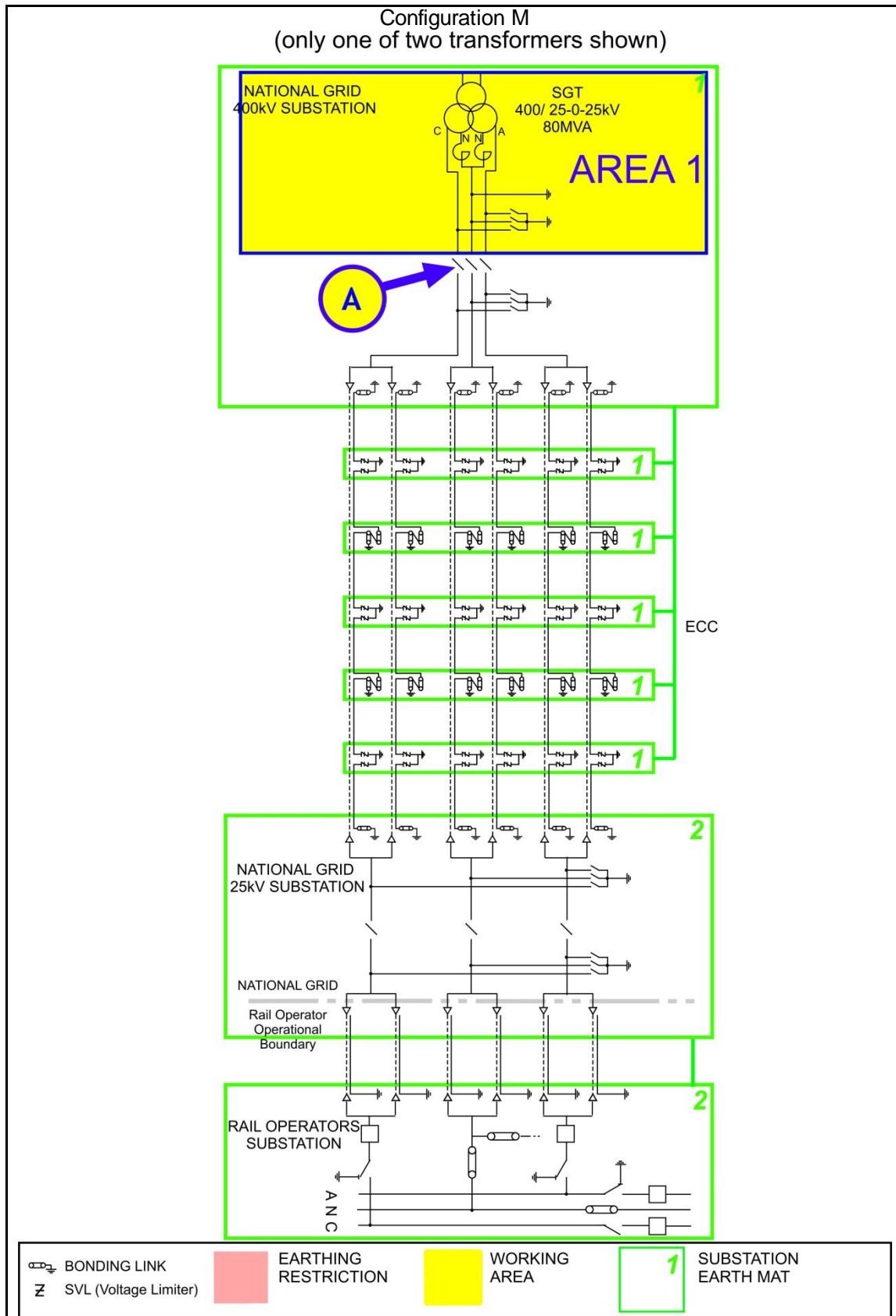

The following table is not a switching sequence. A **Senior Authorised Person** shall include the following tabulated precautions on **Equipment** as part of a switching, isolating and earthing sequence to eliminate *ACR Current* from the designated working AREA.

AREA 1

Equipment	Precautions Required	Reason
Disconnecter A	Check open, lock and apply the "Do Not Close Notice"	To prevent <i>ACR Current</i> from finding a return path through the work area.

CONFIGURATION M – AREA 2A AND 2B

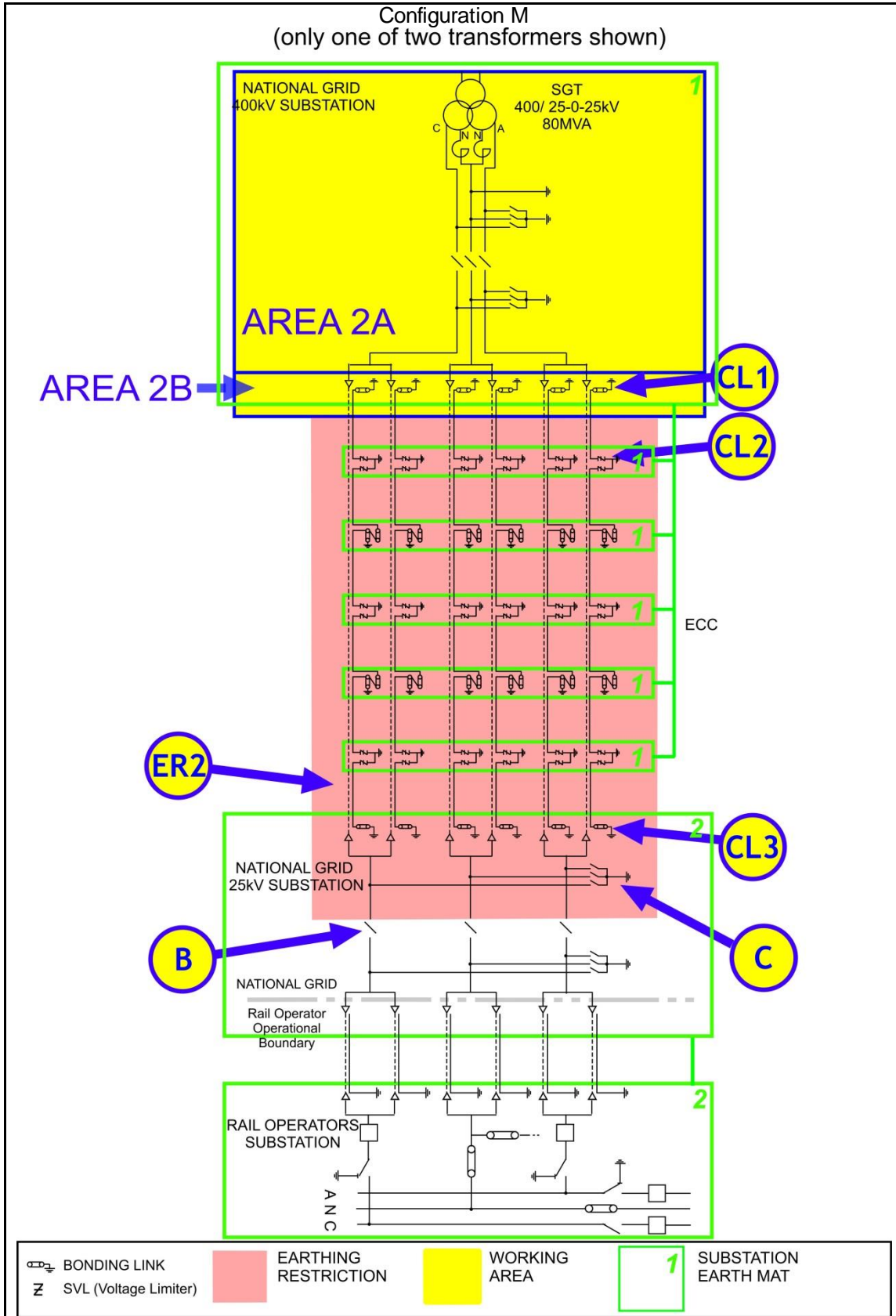

The following table is not a switching sequence. A **Senior Authorised Person** shall include the following tabulated precautions on **Equipment** as part of a switching, isolating and earthing sequence to eliminate *ACR Current* from the designated working AREA.

AREA 2A

Equipment	Precautions Required	Reason
Disconnect B	Check open, lock and apply the "Do Not Close Notice"	Disconnect conductors from 25kV substation and Rail Operators System to stop <i>ACR Current</i> between earth mats via the <i>Poles</i> and <i>Neutral Conductors</i> .
Earth Switch C	Open Earth Switch c and apply the "Do Not Earth Conductors Notice"	This precaution is necessary as an earth on any of the <i>Poles</i> or <i>Neutral Conductor</i> will create a parallel path through which <i>ACR Current</i> will flow.
Earth restriction region ER2	Do not apply earths on Equipment inside region ER2.	This precaution is necessary, as an earth on any of the <i>Poles</i> , <i>Neutral Conductor</i> or cable sheath will create a parallel path through which <i>ACR Current</i> will flow.

AREA 2B

If works are required on, or that could infringe the **Safety Distance** to, the cables, cable sealing ends or cable sheath connections then the following additional requirement to those for AREA 2A applies.

Equipment	Precautions Required	Reason
Cable sheath SVLs, CL2	Remove the sheath voltage limiter from the cable section passing into the work area in accordance with the principles of NSI 5. Apply the "Do Not Earth Conductors Notice"	These SVLs are removed in case the SVLs are not operating correctly. Removal of the SVLs from all cables will prevent <i>ACR Current</i> flowing between the earth mats along the cable sheaths. NOTE: The cable bonding links "CL1" at the solidly bonded position shall be removed prior to removing / replacing the SVL at "CL2" position. "CL1" shall not be quoted as an <i>ACR</i> precaution.
Cable sheath bonding links CL3	Remove cable sheath earth and bonding links. Apply the "Do Not Earth Conductors Notice".	These links are to be removed in case the SVLs are not operating correctly. Removal of the links from all cables will prevent <i>ACR Current</i> flowing between the earth mats along the cable sheaths.

For guidance on the use of AREA 2B or AREA 3A refer to section 4.3 of this document.

For multiple work locations on cables or their accessories refer to section 8.1 of this document.

CONFIGURATION M – AREA 3A

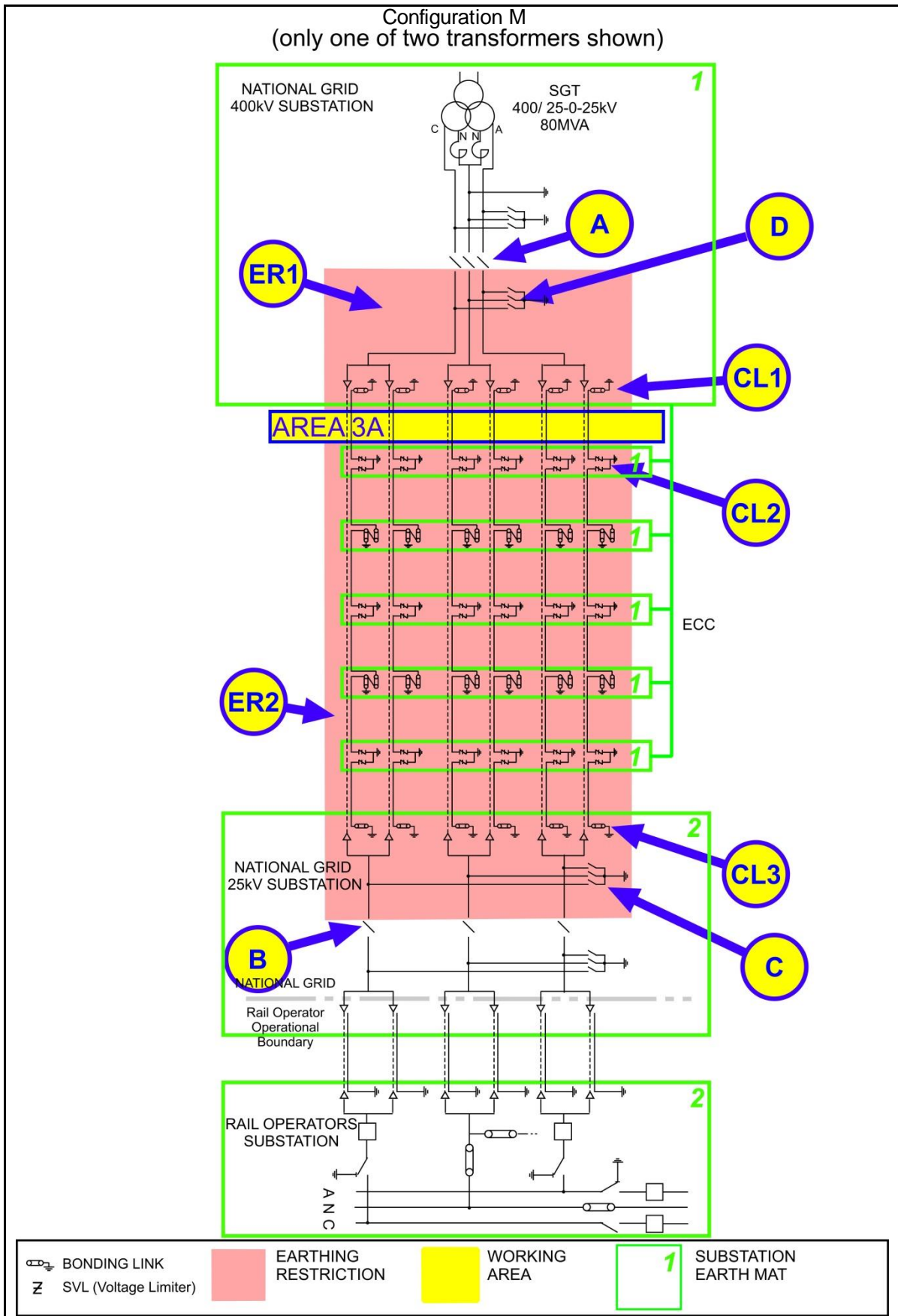

The following table is not a switching sequence. A **Senior Authorised Person** shall include the following tabulated precautions on **Equipment** as part of a switching, isolating and earthing sequence to eliminate *ACR Current* from the designated working AREA.

AREA 3A

Equipment	Precautions Required	Reason
Disconnectors A and B	Check open, lock and apply the "Do Not Close Notice"	Disconnect conductors from 25kV substation and Rail Operators System to stop <i>ACR Current</i> between earth mats via the <i>Poles and Neutral Conductors</i> .
Earth Switches C and D	Open Earth Switch and apply the "Do Not Earth Conductors Notice"	This precaution is necessary to prevent <i>ACR Current</i> flowing along the cable and through the mass of earth when an earth is placed on a cable conductor or sheath in the work area.
Earth restriction region ER1 and ER2	Do not apply earths on Equipment inside regions ER1 or ER2.	This precaution is necessary to prevent <i>ACR Current</i> flowing along the cable and through the mass of earth when an earth is placed on a cable conductor or sheath in the work area. The placing of an earth in the restricted region(s) would create an alternative path for <i>ACR Currents</i> .
Cable sheath bonding links CL1	Remove cable sheath earth and bonding links. Apply the "Do Not Earth Conductors Notice".	These links are to be removed in case the SVLs are not operating correctly. Removal of the links from all cables will prevent <i>ACR Current</i> flowing between the earth mats along the cable sheaths.
Cable sheath SVLs, CL2	Remove the sheath voltage limiter from the cable section passing into the work area in accordance with the principles of NSI 5. Apply the "Do Not Earth Conductors Notice"	These SVLs are removed in case the SVLs are not operating correctly. Removal of the SVLs from all cables will prevent <i>ACR Current</i> flowing between the earth mats along the cable sheaths.
Cable sheath bonding links CL3	Remove cable sheath earth and bonding links. Apply the "Do Not Earth Conductors Notice".	These links are to be removed in case the SVLs are not operating correctly. Removal of the links from all cables will prevent <i>ACR Current</i> flowing between the earth mats along the cable sheaths.

For guidance on the use of AREA 2B or AREA 3A refer to section 4.3 of this document.

For multiple work locations on cables or their accessories refer to section 8.1 of this document.

CONFIGURATION M – AREA 3B

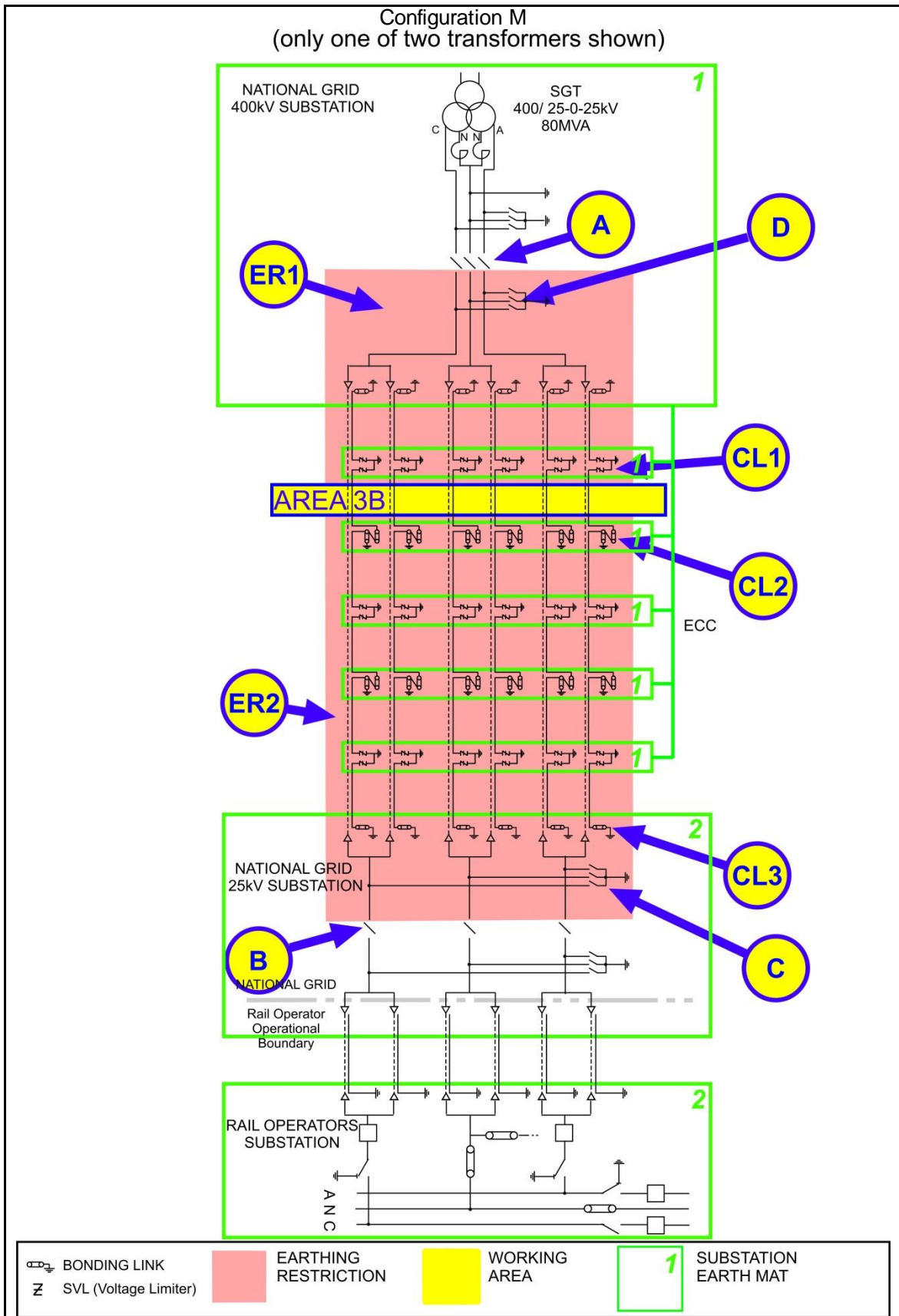

The following table is not a switching sequence. A **Senior Authorised Person** shall include the following tabulated precautions on **Equipment** as part of a switching, isolating and earthing sequence to eliminate *ACR Current* from the designated working AREA.

AREA 3B

Equipment	Precautions Required	Reason
Disconnectors A and B	Check open, lock and apply the "Do Not Close Notice"	Disconnect conductors from 25kV substation and Rail Operators System to stop <i>ACR Current</i> between earth mats via the <i>Poles and Neutral Conductors</i> .
Earth Switches C and D	Open Earth Switch and apply the "Do Not Earth Conductors Notice"	This precaution is necessary to prevent <i>ACR Current</i> flowing along the cable and through the mass of earth when an earth is placed on a cable conductor or sheath in the work area.
Earth restriction region ER1 and ER2	Do not apply earths on Equipment inside regions ER1 or ER2.	This precaution is necessary to prevent <i>ACR Current</i> flowing along the cable and through the mass of earth when an earth is placed on a cable conductor or sheath in the work area. The placing of an earth in the restricted region(s) would create an alternative path for <i>ACR Currents</i> .
Cable sheath SVLs, CL1	Remove the sheath voltage limiter from the cable section passing into the work area in accordance with the principles of NSI 5. Apply the "Do Not Earth Conductors Notice"	These SVLs are removed in case the SVLs are not operating correctly. Removal of the SVLs from all cables will prevent <i>ACR Current</i> flowing between the earth mats along the cable sheaths.
Cable sheath bonding links CL2	Remove all cable sheath earth and bonding links from the cable section passing through the work area. Apply the "Do Not Earth Conductors Notice".	These links are to be removed in case the SVLs are not operating correctly. Removal of the links from all cables will prevent <i>ACR Current</i> flowing between the earth mats along the cable sheaths. Note: No links should remain in place which connect the cable section in the work area to either another cable section or earth,
Cable sheath bonding links CL3	Remove cable sheath earth and bonding links. Apply the "Do Not Earth Conductors Notice".	These links are to be removed in case the SVLs are not operating correctly. Removal of the links from all cables will prevent <i>ACR Current</i> flowing between the earth mats along the cable sheaths.

For guidance on the use of AREA 3B refer to section 4.3 of this document.

For multiple work locations on cables or their accessories refer to section 8.1 of this document.

CONFIGURATION M – AREA 3C

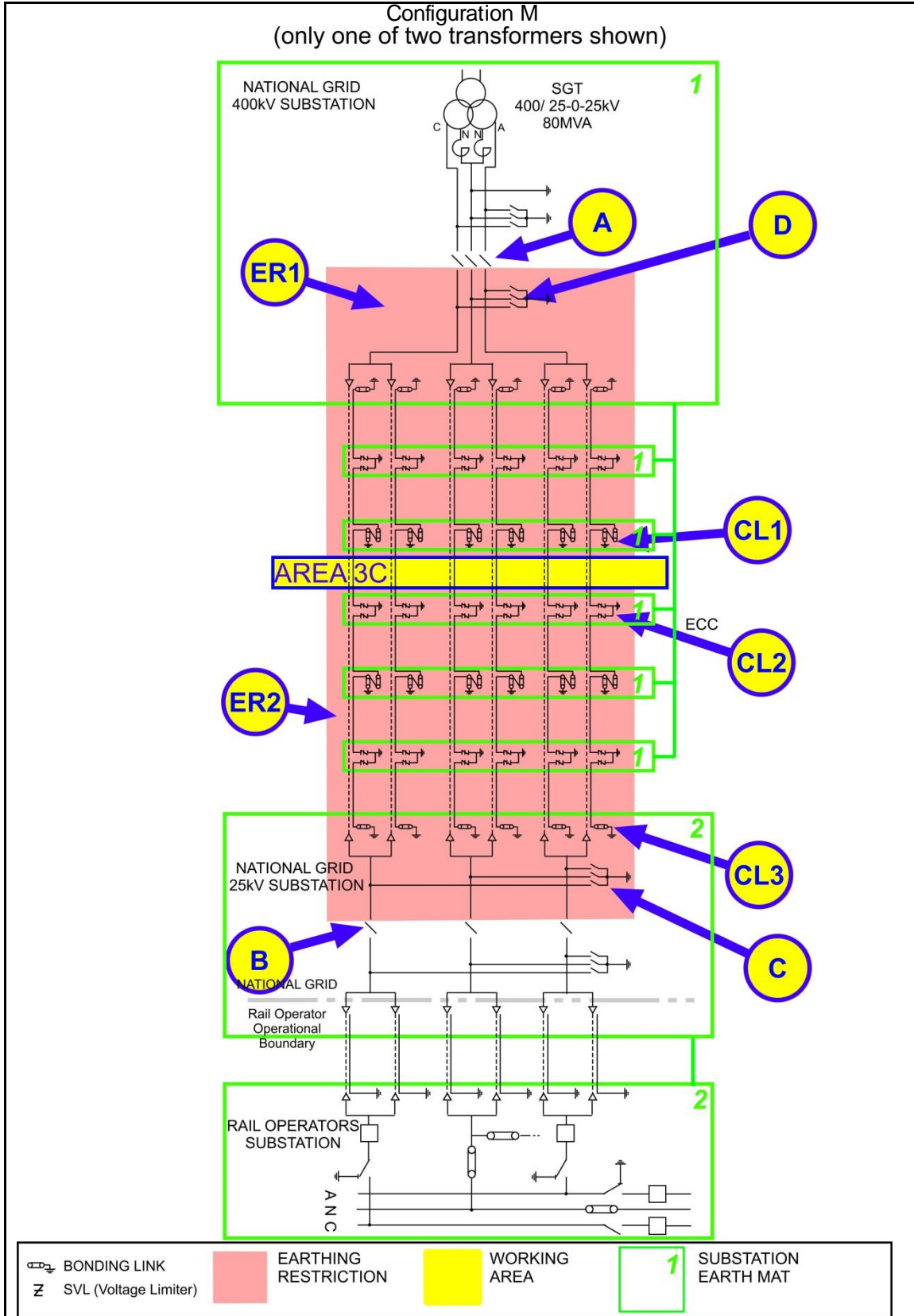

The following table is not a switching sequence. A **Senior Authorised Person** shall include the following tabulated precautions on **Equipment** as part of a switching, isolating and earthing sequence to eliminate *ACR Current* from the designated working AREA.

AREA 3C

Equipment	Precautions Required	Reason
Disconnectors A and B	Check open, lock and apply the "Do Not Close Notice"	Disconnect conductors from 25kV substation and Rail Operators System to stop <i>ACR Current</i> between earth mats via the <i>Poles</i> and <i>Neutral Conductors</i> .
Earth Switches C and D	Open Earth Switch and apply the "Do Not Earth Conductors Notice"	This precaution is necessary to prevent <i>ACR Current</i> flowing along the cable and through the mass of earth when an earth is placed on a cable conductor or sheath in the work area.
Earth restriction region ER1 and ER2	Do not apply earths on Equipment inside regions ER1 or ER2.	This precaution is necessary to prevent <i>ACR Current</i> flowing along the cable and through the mass of earth when an earth is placed on a cable conductor or sheath in the work area. The placing of an earth in the restricted region(s) would create an alternative path for <i>ACR Currents</i> .
Cable sheath bonding links CL1	Remove all cable sheath earth and bonding links from the cable section passing through the work area. Apply the "Do Not Earth Conductors Notice".	These links are to be removed in case the SVLs are not operating correctly. Removal of the links from all cables will prevent <i>ACR Current</i> flowing between the earth mats along the cable sheaths. Note: No links should remain in place which connect the cable section in the work area to either another cable section or earth,
Cable sheath SVLs, CL2	Remove the sheath voltage limiter in accordance with the principles of NSI 5. Apply the "Do Not Earth Conductors Notice"	These SVLs are removed in case the SVLs are not operating correctly. Removal of the SVLs from all cables will prevent <i>ACR Current</i> flowing between the earth mats along the cable sheaths.
Cable sheath bonding links CL3	Remove cable sheath earth and bonding links. Apply the "Do Not Earth Conductors Notice".	These links are to be removed in case the SVLs are not operating correctly. Removal of the links from all cables will prevent <i>ACR Current</i> flowing between the earth mats along the cable sheaths.

For guidance on the use of AREA 3C refer to section 4.3 of this document.

For multiple work locations on cables or their accessories refer to section 8.1 of this document.

CONFIGURATION M – AREA 3D

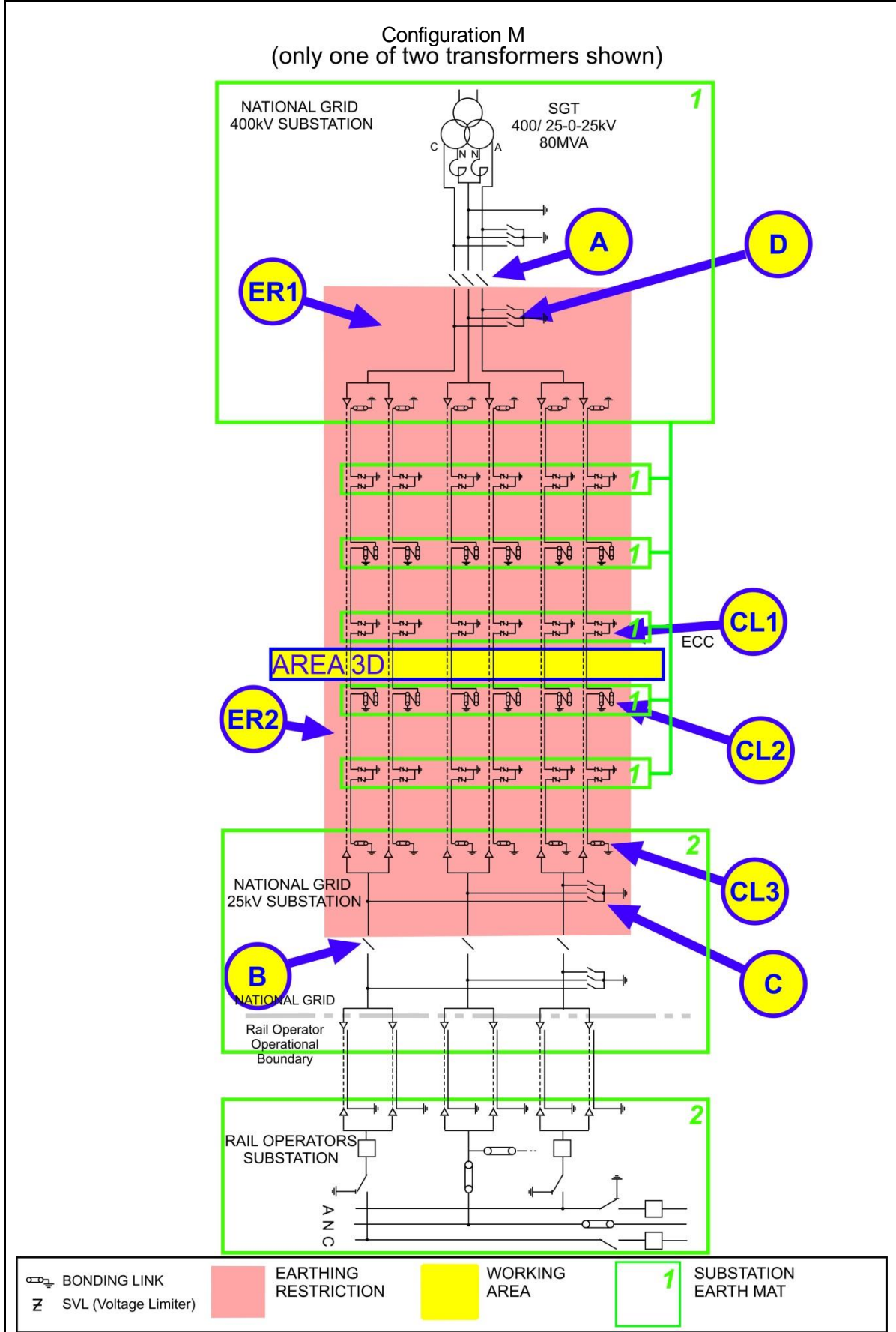

The following table is not a switching sequence. A **Senior Authorised Person** shall include the following tabulated precautions on **Equipment** as part of a switching, isolating and earthing sequence to eliminate *ACR Current* from the designated working AREA.

AREA 3D

Equipment	Precautions Required	Reason
Disconnectors A and B	Check open, lock and apply the "Do Not Close Notice"	Disconnect conductors from 25kV substation and Rail Operators System to stop <i>ACR Current</i> between earth mats via the <i>Poles and Neutral Conductors</i> .
Earth Switches C and D	Open Earth Switch and apply the "Do Not Earth Conductors Notice"	This precaution is necessary to prevent <i>ACR Current</i> flowing along the cable and through the mass of earth when an earth is placed on a cable conductor or sheath in the work area.
Earth restriction region ER1 and ER2	Do not apply earths on Equipment inside regions ER1 or ER2.	This precaution is necessary to prevent <i>ACR Current</i> flowing along the cable and through the mass of earth when an earth is placed on a cable conductor or sheath in the work area. The placing of an earth in the restricted region(s) would create an alternative path for <i>ACR Currents</i> .
Cable sheath SVLs, CL1	Remove the sheath voltage limiter in accordance with the principles of NSI 5. Apply the "Do Not Earth Conductors Notice"	These SVLs are removed in case the SVLs are not operating correctly. Removal of the SVLs from all cables will prevent <i>ACR Current</i> flowing between the earth mats along the cable sheaths.
Cable sheath bonding links CL2	Remove all cable sheath earth and bonding links from the cable section passing through the work area. Apply the "Do Not Earth Conductors Notice".	These links are to be removed in case the SVLs are not operating correctly. Removal of the links from all cables will prevent <i>ACR Current</i> flowing between the earth mats along the cable sheaths. Note: No links should remain in place which connect the cable section in the work area to either another cable section or earth,
Cable sheath bonding links CL3	Remove cable sheath earth and bonding links. Apply the "Do Not Earth Conductors Notice".	These links are to be removed in case the SVLs are not operating correctly. Removal of the links from all cables will prevent <i>ACR Current</i> flowing between the earth mats along the cable sheaths.

For guidance on the use of AREA 3D refer to section 4.3 of this document.

For multiple work locations on cables or their accessories refer to section 8.1 of this document.

CONFIGURATION M – AREA 3E

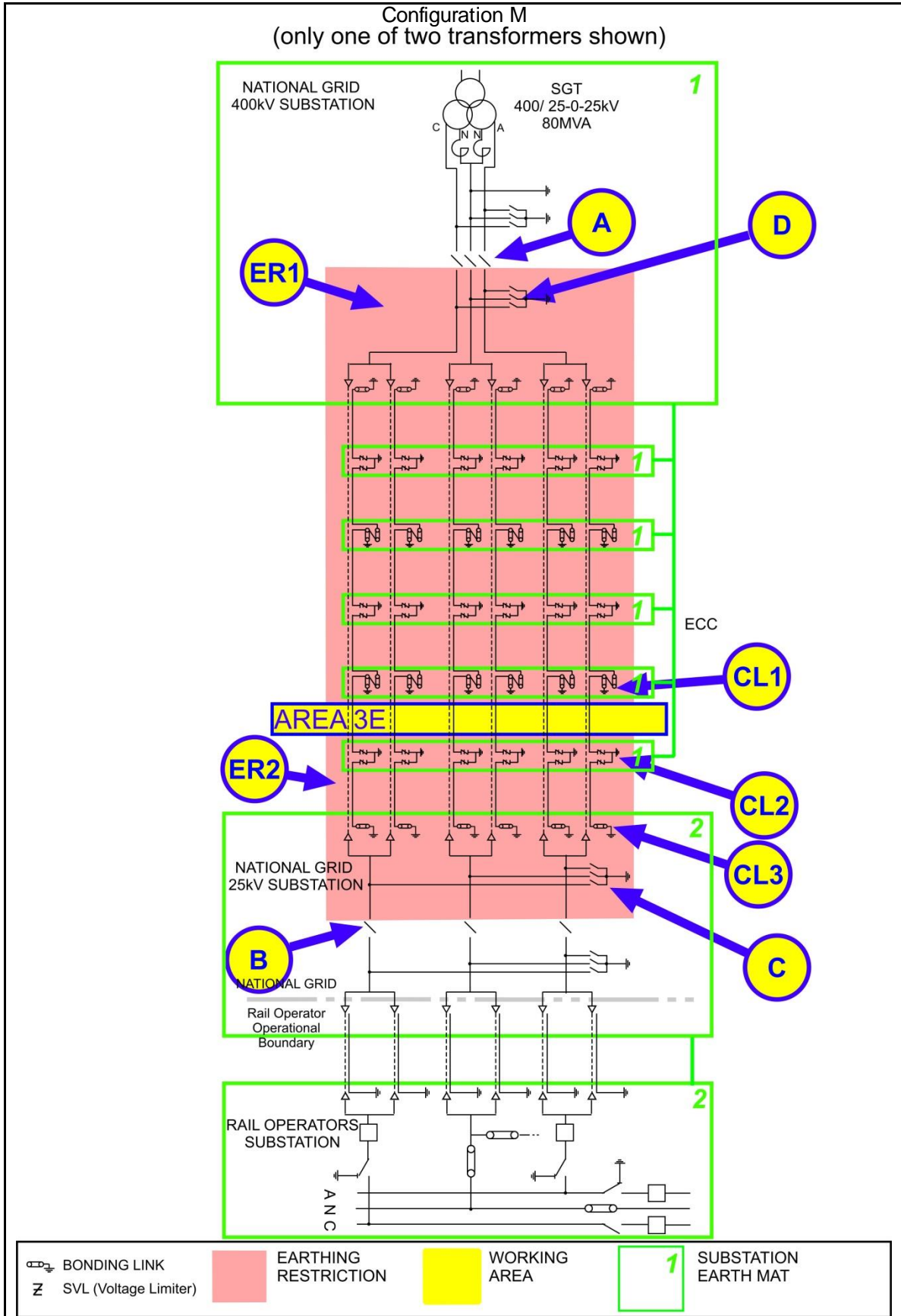

The following table is not a switching sequence. A **Senior Authorised Person** shall include the following tabulated precautions on **Equipment** as part of a switching, isolating and earthing sequence to eliminate *ACR Current* from the designated working AREA.

AREA 3E

Equipment	Precautions Required	Reason
Disconnectors A and B	Check open, lock and apply the "Do Not Close Notice"	Disconnect conductors from 25kV substation and Rail Operators System to stop <i>ACR Current</i> between earth mats via the <i>Poles and Neutral Conductors</i> .
Earth Switches C and D	Open Earth Switch and apply the "Do Not Earth Conductors Notice"	This precaution is necessary to prevent <i>ACR Current</i> flowing along the cable and through the mass of earth when an earth is placed on a cable conductor or sheath in the work area.
Earth restriction region ER1 and ER2	Do not apply earths on Equipment inside regions ER1 or ER2.	This precaution is necessary to prevent <i>ACR Current</i> flowing along the cable and through the mass of earth when an earth is placed on a cable conductor or sheath in the work area. The placing of an earth in the restricted region(s) would create an alternative path for <i>ACR Currents</i> .
Cable sheath bonding links CL1	Remove all cable sheath earth and bonding links from the cable section passing through the work area. Apply the "Do Not Earth Conductors Notice".	These links are to be removed in case the SVLs are not operating correctly. Removal of the links from all cables will prevent <i>ACR Current</i> flowing between the earth mats along the cable sheaths. Note: No links should remain in place which connect the cable section in the work area to either another cable section or earth,
Cable sheath SVLs, CL2	Remove the sheath voltage limiter in accordance with the principles of NSI 5. Apply the "Do Not Earth Conductors Notice"	These SVLs are removed in case the SVLs are not operating correctly. Removal of the SVLs from all cables will prevent <i>ACR Current</i> flowing between the earth mats along the cable sheaths.
Cable sheath bonding links CL3	Remove cable sheath earth and bonding links. Apply the "Do Not Earth Conductors Notice".	These links are to be removed in case the SVLs are not operating correctly. Removal of the links from all cables will prevent <i>ACR Current</i> flowing between the earth mats along the cable sheaths.

For guidance on the use of AREA 3E refer to section 4.3 of this document.

For multiple work locations on cables or their accessories refer to section 8.1 of this document.

CONFIGURATION M – AREA 3F

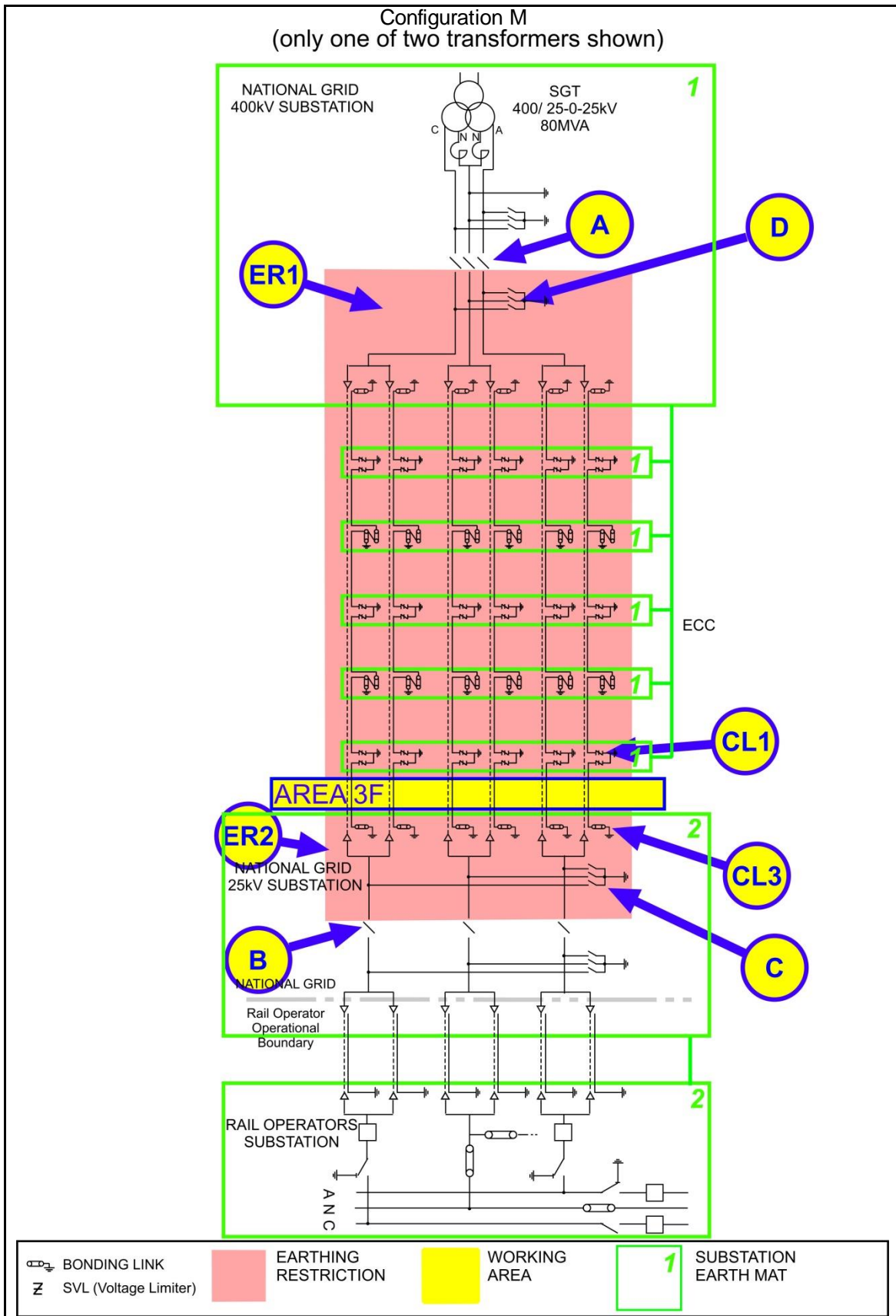

The following table is not a switching sequence. A **Senior Authorised Person** shall include the following tabulated precautions on **Equipment** as part of a switching, isolating and earthing sequence to eliminate *ACR Current* from the designated working AREA.

AREA 3F

Equipment	Precautions Required	Reason
Disconnectors A and B	Check open, lock and apply the "Do Not Close Notice"	Disconnect conductors from 25kV substation and Rail Operators System to stop <i>ACR Current</i> between earth mats via the <i>Poles and Neutral Conductors</i> .
Earth Switches C and D	Open Earth Switch and apply the "Do Not Earth Conductors Notice"	This precaution is necessary to prevent <i>ACR Current</i> flowing along the cable and through the mass of earth when an earth is placed on a cable conductor or sheath in the work area.
Earth restriction region ER1 and ER2	Do not apply earths on Equipment inside regions ER1 or ER2.	This precaution is necessary to prevent <i>ACR Current</i> flowing along the cable and through the mass of earth when an earth is placed on a cable conductor or sheath in the work area. The placing of an earth in the restricted region(s) would create an alternative path for <i>ACR Currents</i> .
Cable sheath SVLs, CL1	Remove the sheath voltage limiter in accordance with the principles of NSI 5. Apply the "Do Not Earth Conductors Notice"	These SVLs are removed in case the SVLs are not operating correctly. Removal of the SVLs from all cables will prevent <i>ACR Current</i> flowing between the earth mats along the cable sheaths.
Cable sheath bonding links CL3	Remove cable sheath earth and bonding links. Apply the "Do Not Earth Conductors Notice".	These links are to be removed in case the SVLs are not operating correctly. Removal of the links from all cables will prevent <i>ACR Current</i> flowing between the earth mats along the cable sheaths.

For guidance on the use of AREA 3F or AREA 16B refer to section 4.3 of this document.

For multiple work locations on cables or their accessories refer to section 8.1 of this document.

CONFIGURATION M – AREA 15A

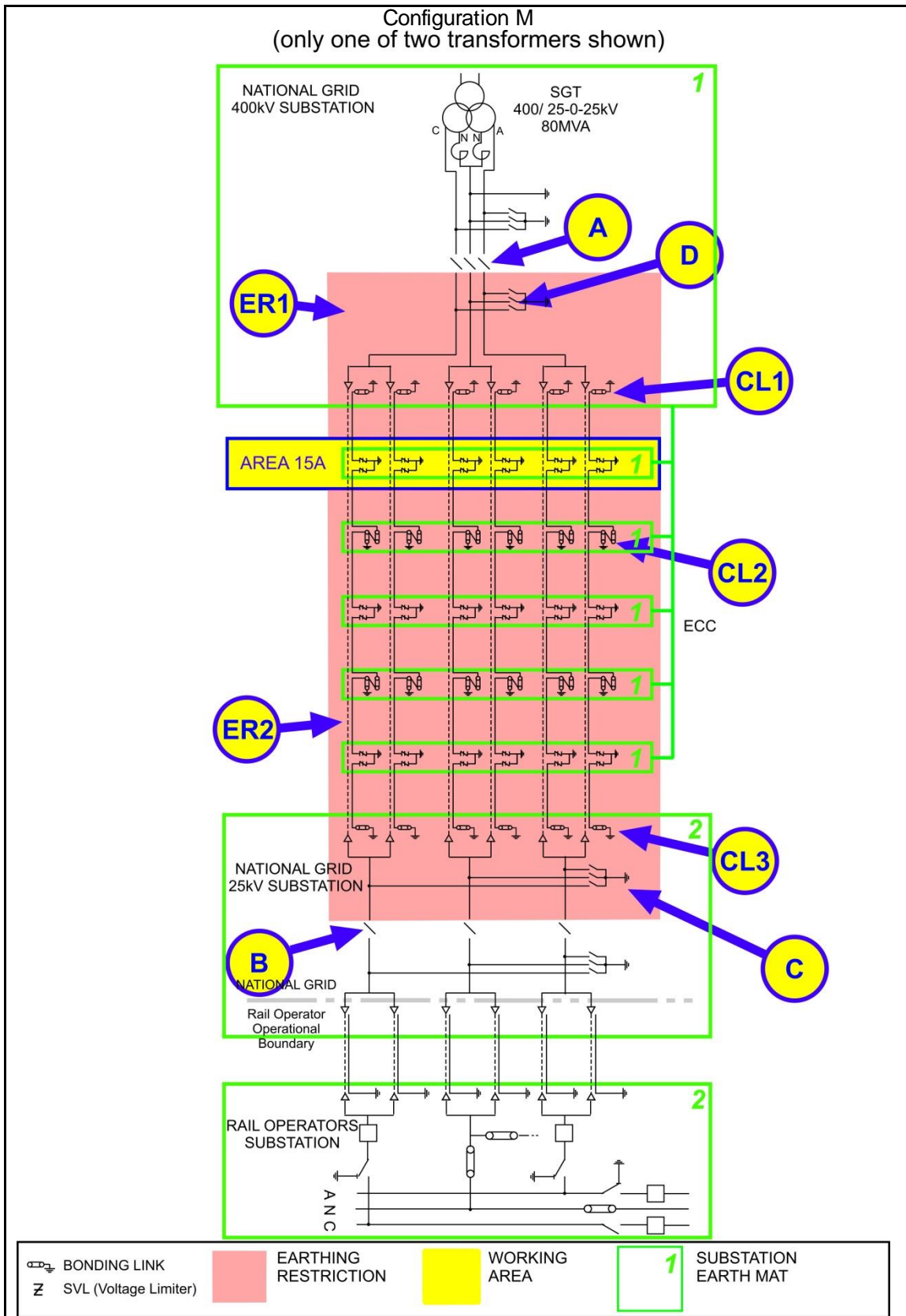

The following table is not a switching sequence. A **Senior Authorised Person** shall include the following tabulated precautions on **Equipment** as part of a switching, isolating and earthing sequence to eliminate *ACR Current* from the designated working AREA.

AREA 15A

Equipment	Precautions Required	Reason
Disconnectors A and B	Check open, lock and apply the "Do Not Close Notice"	Disconnect conductors from 25kV substation and Rail Operators System to stop <i>ACR Current</i> between earth mats via the <i>Poles</i> and <i>Neutral Conductors</i> .
Earth Switches C and D	Open Earth Switch and apply the "Do Not Earth Conductors Notice"	This precaution is necessary to prevent <i>ACR Current</i> flowing along the cable and through the mass of earth when an earth is placed on a cable conductor or sheath in the work area.
Earth restriction region ER1 and ER2	Do not apply earths on Equipment inside regions ER1 or ER2.	This precaution is necessary to prevent <i>ACR Current</i> flowing along the cable and through the mass of earth when an earth is placed on a cable conductor or sheath in the work area. The placing of an earth in the restricted region(s) would create an alternative path for <i>ACR Currents</i> .
Cable sheath bonding links CL1	Remove cable sheath earth and bonding links. Apply the "Do Not Earth Conductors Notice".	These links are to be removed in case the SVLs are not operating correctly. Removal of the links from all cables will prevent <i>ACR Current</i> flowing between the earth mats along the cable sheaths.
Cable sheath bonding links CL2	Remove all cable sheath earth and bonding links from the cable section passing through the work area. Apply the "Do Not Earth Conductors Notice".	These links are to be removed in case the SVLs are not operating correctly. Removal of the links from all cables will prevent <i>ACR Current</i> flowing between the earth mats along the cable sheaths. Note: No links should remain in place which connect the cable section in the work area to either another cable section or earth,
Cable sheath bonding links CL3	Remove cable sheath earth and bonding links. Apply the "Do Not Earth Conductors Notice".	These links are to be removed in case the SVLs are not operating correctly. Removal of the links from all cables will prevent <i>ACR Current</i> flowing between the earth mats along the cable sheaths.

For guidance on the use of AREA 15A refer to section 4.3 of this document,

For multiple work locations on cables or their accessories refer to section 8.1 of this document.

CONFIGURATION M – AREA 15B

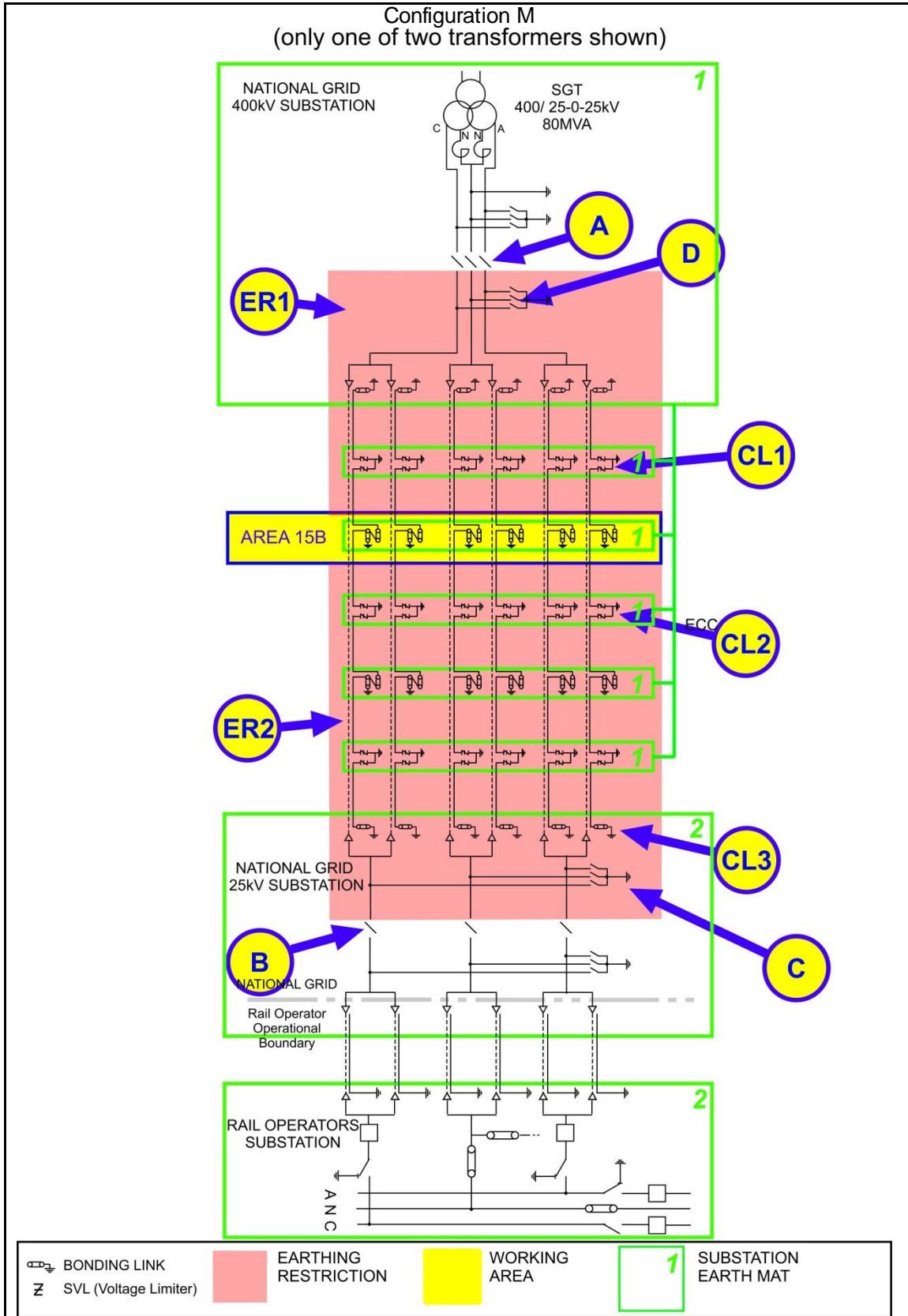

The following table is not a switching sequence. A **Senior Authorised Person** shall include the following tabulated precautions on **Equipment** as part of a switching, isolating and earthing sequence to eliminate *ACR Current* from the designated working AREA.

AREA 15B

Equipment	Precautions Required	Reason
Disconnectors A and B	Check open, lock and apply the "Do Not Close Notice"	Disconnect conductors from 25kV substation and Rail Operators System to stop <i>ACR Current</i> between earth mats via the <i>Poles and Neutral Conductors</i> .
Earth Switches C and D	Open Earth Switch and apply the "Do Not Earth Conductors Notice"	This precaution is necessary to prevent <i>ACR Current</i> flowing along the cable and through the mass of earth when an earth is placed on a cable conductor or sheath in the work area.
Earth restriction region ER1 and ER2	Do not apply earths on Equipment inside regions ER1 or ER2.	This precaution is necessary to prevent <i>ACR Current</i> flowing along the cable and through the mass of earth when an earth is placed on a cable conductor or sheath in the work area. The placing of an earth in the restricted region(s) would create an alternative path for <i>ACR Currents</i> .
Cable sheath SVLs, CL1 and CL2	Remove the sheath voltage limiter in accordance with the principles of NSI 5. Apply the "Do Not Earth Conductors Notice"	These SVLs are removed in case the SVLs are not operating correctly. Removal of the SVLs from all cables will prevent <i>ACR Current</i> flowing between the earth mats along the cable sheaths.
Cable sheath bonding links CL3	Remove cable sheath earth and bonding links. Apply the "Do Not Earth Conductors Notice".	These links are to be removed in case the SVLs are not operating correctly. Removal of the links from all cables will prevent <i>ACR Current</i> flowing between the earth mats along the cable sheaths.

For guidance on the use of AREA 15B refer to section 4.3 of this document,

For multiple work locations on cables or their accessories refer to section 8.1 of this document.

CONFIGURATION M – AREA 15C

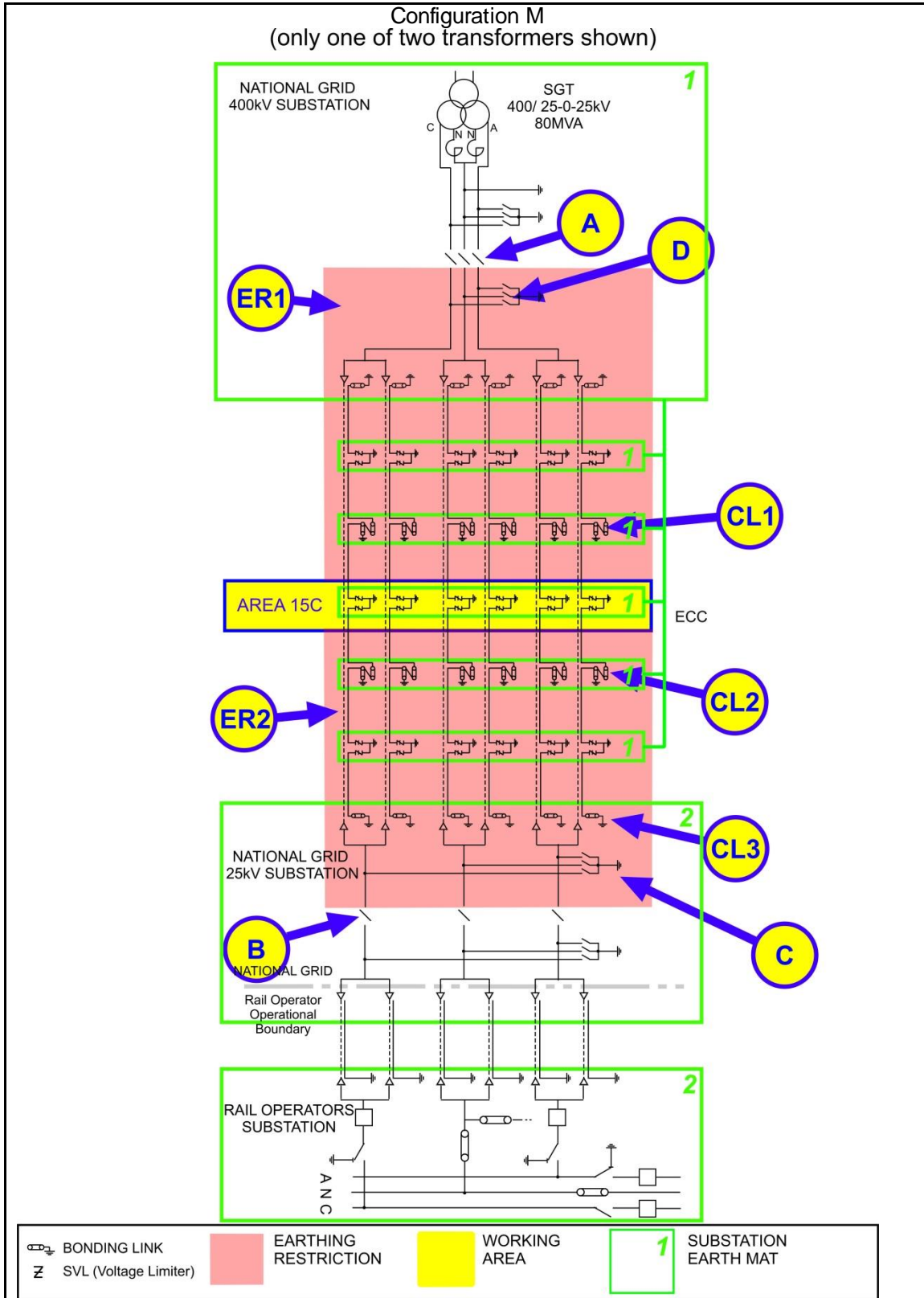

The following table is not a switching sequence. A **Senior Authorised Person** shall include the following tabulated precautions on **Equipment** as part of a switching, isolating and earthing sequence to eliminate *ACR Current* from the designated working AREA.

AREA 15C

Equipment	Precautions Required	Reason
Disconnectors A and B	Check open, lock and apply the "Do Not Close Notice"	Disconnect conductors from 25kV substation and Rail Operators System to stop <i>ACR Current</i> between earth mats via the <i>Poles and Neutral Conductors</i> .
Earth Switches C and D	Open Earth Switch c and apply the "Do Not Earth Conductors Notice"	This precaution is necessary to prevent <i>ACR Current</i> flowing along the cable and through the mass of earth when an earth is placed on a cable conductor or sheath in the work area.
Earth restriction region ER1 and ER2	Do not apply earths on Equipment inside regions ER1 or ER2.	This precaution is necessary to prevent <i>ACR Current</i> flowing along the cable and through the mass of earth when an earth is placed on a cable conductor or sheath in the work area. The placing of an earth in the restricted region(s) would create an alternative path for <i>ACR Currents</i> .
Cable sheath bonding links CL1 & CL2	Remove all cable sheath earth and bonding links from the cable section passing through the work area. Apply the "Do Not Earth Conductors Notice".	These links are to be removed in case the SVLs are not operating correctly. Removal of the links from all cables will prevent <i>ACR Current</i> flowing between the earth mats along the cable sheaths. Note: No links should remain in place which connect the cable section in the work area to either another cable section or earth,
Cable sheath bonding links CL3	Remove cable sheath earth and bonding links. Apply the "Do Not Earth Conductors Notice".	These links are to be removed in case the SVLs are not operating correctly. Removal of the links from all cables will prevent <i>ACR Current</i> flowing between the earth mats along the cable sheaths.

For guidance on the use of AREA 15C refer to section 4.3 of this document,

For multiple work locations on cables or their accessories refer to section 8.1 of this document.

CONFIGURATION M – AREA 15D

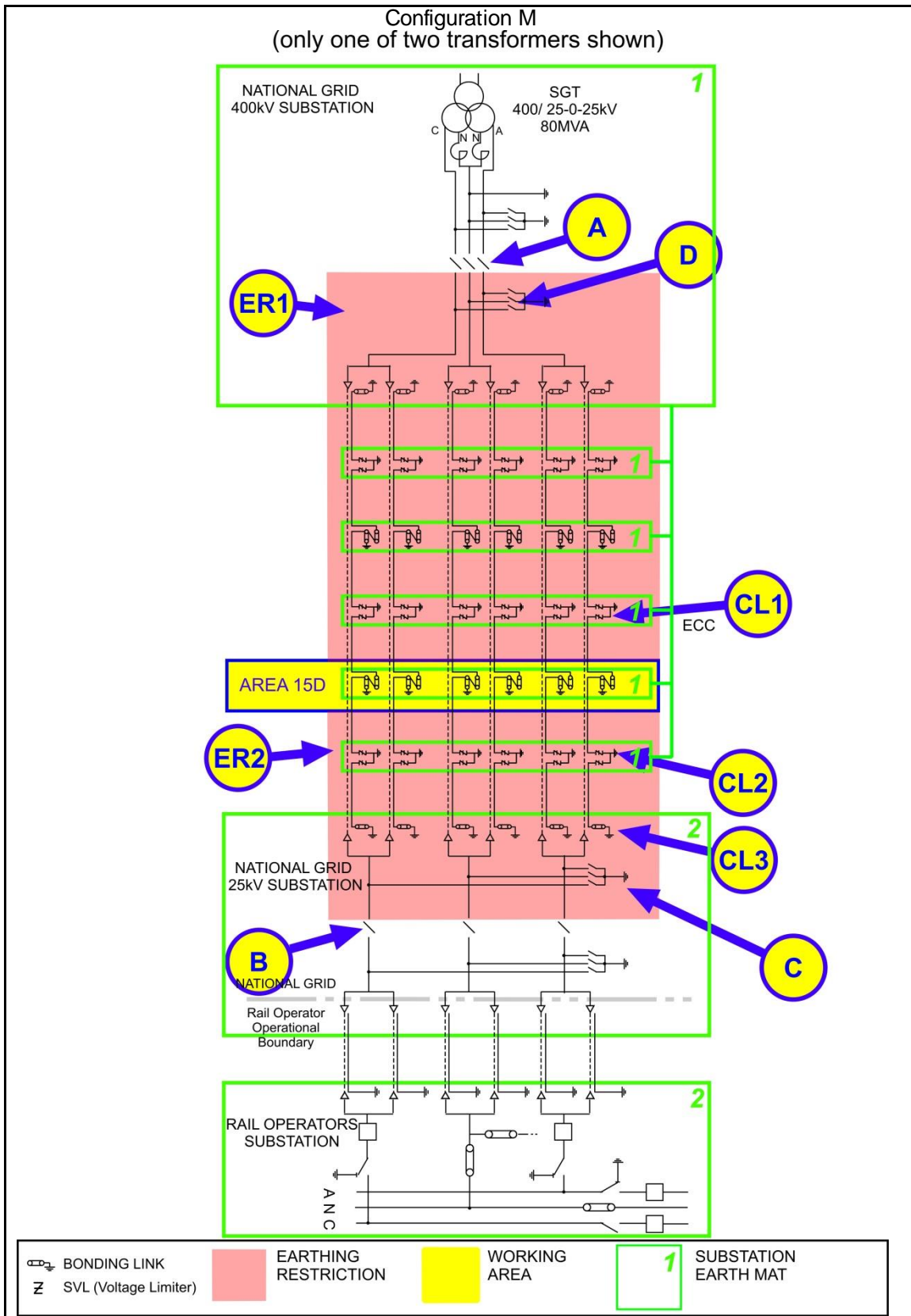

The following table is not a switching sequence. A **Senior Authorised Person** shall include the following tabulated precautions on **Equipment** as part of a switching, isolating and earthing sequence to eliminate *ACR Current* from the designated working AREA.

AREA 15D

Equipment	Precautions Required	Reason
Disconnectors A and B	Check open, lock and apply the "Do Not Close Notice"	Disconnect conductors from 25kV substation and Rail Operators System to stop <i>ACR Current</i> between earth mats via the <i>Poles and Neutral Conductors</i> .
Earth Switches C and D	Open Earth Switch and apply the "Do Not Earth Conductors Notice"	This precaution is necessary to prevent <i>ACR Current</i> flowing along the cable and through the mass of earth when an earth is placed on a cable conductor or sheath in the work area.
Earth restriction region ER1 and ER2	Do not apply earths on Equipment inside regions ER1 or ER2.	This precaution is necessary to prevent <i>ACR Current</i> flowing along the cable and through the mass of earth when an earth is placed on a cable conductor or sheath in the work area. The placing of an earth in the restricted region(s) would create an alternative path for <i>ACR Currents</i> .
Cable sheath SVLs, CL1 and CL2	Remove the sheath voltage limiter in accordance with the principles of NSI 5. Apply the "Do Not Earth Conductors Notice"	These SVLs are removed in case the SVLs are not operating correctly. Removal of the SVLs from all cables will prevent <i>ACR Current</i> flowing between the earth mats along the cable sheaths.
Cable sheath bonding links CL3	Remove cable sheath earth and bonding links. Apply the "Do Not Earth Conductors Notice".	These links are to be removed in case the SVLs are not operating correctly. Removal of the links from all cables will prevent <i>ACR Current</i> flowing between the earth mats along the cable sheaths.

For guidance on the use of AREA 15D refer to section 4.3 of this document,

For multiple work locations on cables or their accessories refer to section 8.1 of this document.

CONFIGURATION M – AREA 15E

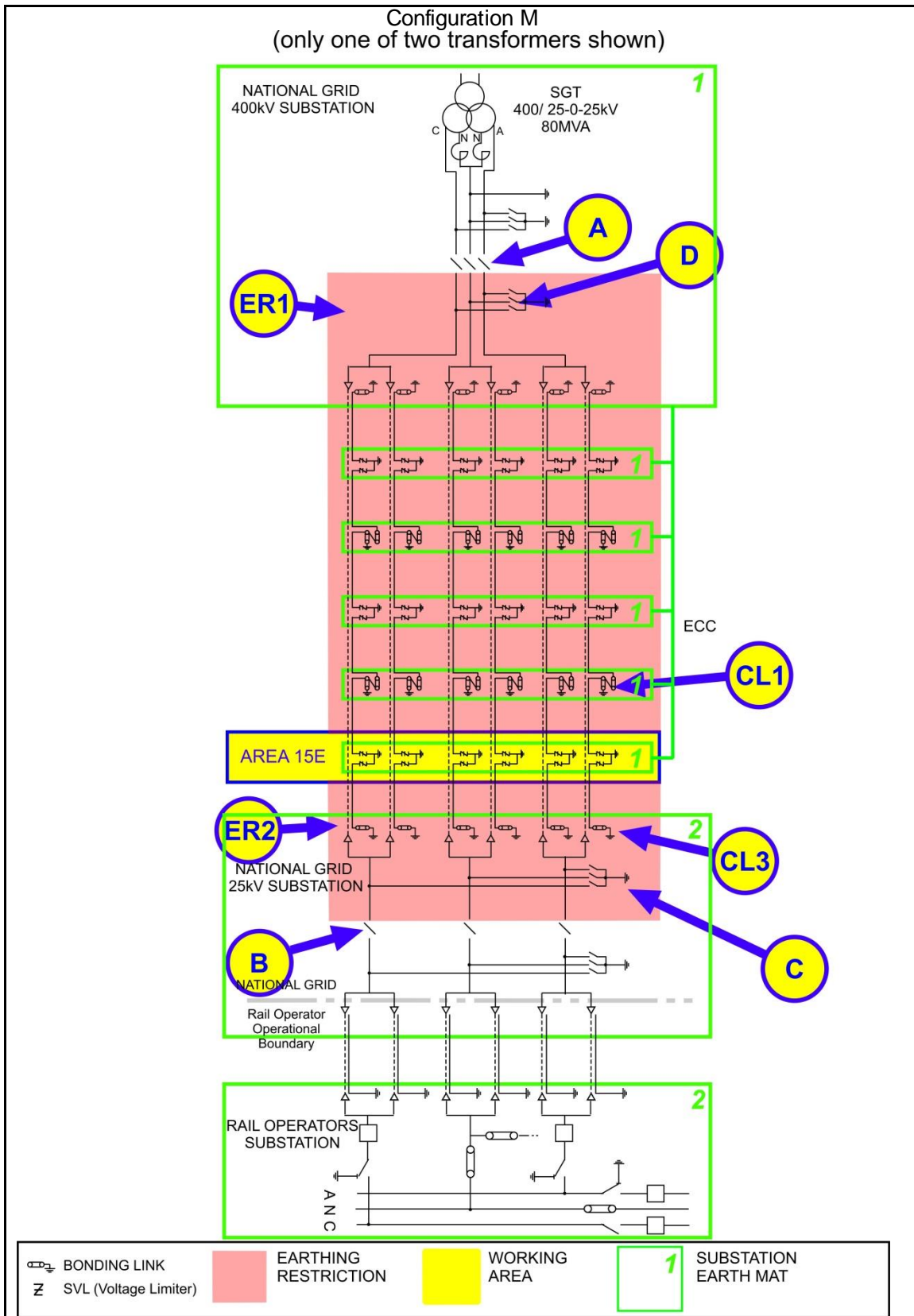

The following table is not a switching sequence. A **Senior Authorised Person** shall include the following tabulated precautions on **Equipment** as part of a switching, isolating and earthing sequence to eliminate *ACR Current* from the designated working AREA.

AREA 15E

Equipment	Precautions Required	Reason
Disconnectors A and B	Check open, lock and apply the "Do Not Close Notice"	Disconnect conductors from 25kV substation and Rail Operators System to stop <i>ACR Current</i> between earth mats via the <i>Poles and Neutral Conductors</i> .
Earth Switches C and D	Open Earth Switch and apply the "Do Not Earth Conductors Notice"	This precaution is necessary to prevent <i>ACR Current</i> flowing along the cable and through the mass of earth when an earth is placed on a cable conductor or sheath in the work area.
Earth restriction region ER1 and ER2	Do not apply earths on Equipment inside regions ER1 or ER2.	This precaution is necessary to prevent <i>ACR Current</i> flowing along the cable and through the mass of earth when an earth is placed on a cable conductor or sheath in the work area. The placing of an earth in the restricted region(s) would create an alternative path for <i>ACR Currents</i> .
Cable sheath bonding links CL1	Remove all cable sheath earth and bonding links from the cable section passing through the work area. Apply the "Do Not Earth Conductors Notice".	These links are to be removed in case the SVLs are not operating correctly. Removal of the links from all cables will prevent <i>ACR Current</i> flowing between the earth mats along the cable sheaths. Note: No links should remain in place which connect the cable section in the work area to either another cable section or earth,
Cable sheath bonding links CL3	Remove cable sheath earth and bonding links. Apply the "Do Not Earth Conductors Notice".	These links are to be removed in case the SVLs are not operating correctly. Removal of the links from all cables will prevent <i>ACR Current</i> flowing between the earth mats along the cable sheaths.

For guidance on the use of AREA 15E refer to section 4.3 of this document,

For multiple work locations on cables or their accessories refer to section 8.1 of this document.

CONFIGURATION M – AREA 16A AND 16B

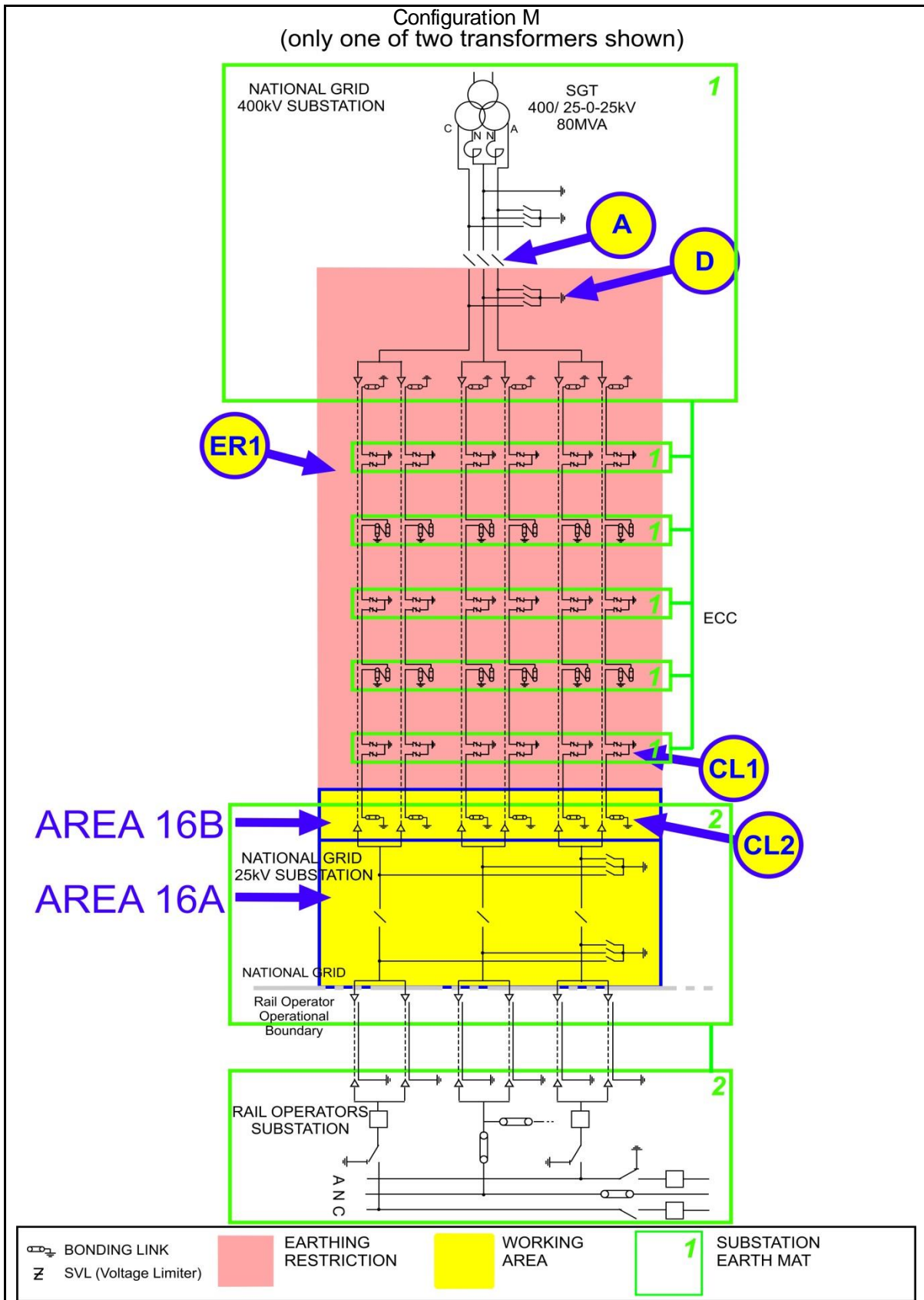

The following table is not a switching sequence. A **Senior Authorised Person** shall include the following tabulated precautions on **Equipment** as part of a switching, isolating and earthing sequence to eliminate *ACR Current* from the designated working AREA.

AREA 16A

Equipment	Precautions Required	Reason
Disconnect A	Check open, lock and apply the "Do Not Close Notice"	Disconnect conductors from 25kV substation and Rail Operators System to stop <i>ACR Current</i> between earth mats via the <i>Poles</i> and <i>Neutral Conductors</i> .
Earth Switch D	Open Earth Switch and apply the "Do Not Earth Conductors Notice"	This precaution is necessary to prevent <i>ACR Current</i> flowing along the cable and through the mass of earth when an earth is placed on a cable conductor or sheath in the work area.
Earth restriction region ER1	Do not apply earths on Equipment inside regions ER1.	This precaution is necessary to prevent <i>ACR Current</i> flowing along the cable and through the mass of earth when an earth is placed on a cable conductor or sheath in the work area. The placing of an earth in the restricted region would create an alternative path for <i>ACR Current(s)</i> .

AREA 16B

If works are required that may infringe **Safety Distance** to, the Cables, Cable sealing ends or Cable Sheath connections then the following additional requirements to those for AREA 16A apply.

Equipment	Precautions Required	Reason
Cable sheath SVLs, CL1	Remove the sheath voltage limiter in accordance with the principles of NSI 5. Apply the "Do Not Earth Conductors Notice"	These SVLs are removed in case the SVLs are not operating correctly. Removal of the SVLs from all cables will prevent <i>ACR Current</i> flowing between the earth mats along the cable sheaths. NOTE: The cable bonding links "CL2" at the solidly bonded position shall be removed prior to removing / replacing the SVL at "CL1" position. "CL2" shall not be quoted as an <i>ACR</i> precaution.

For guidance on the use of AREA 16B or AREA 3F refer to section 4.3 of this document.

For multiple work locations on cables or their accessories refer to section 8.1 of this document.

CONFIGURATION N
CONFIGURATION N – AREA 1

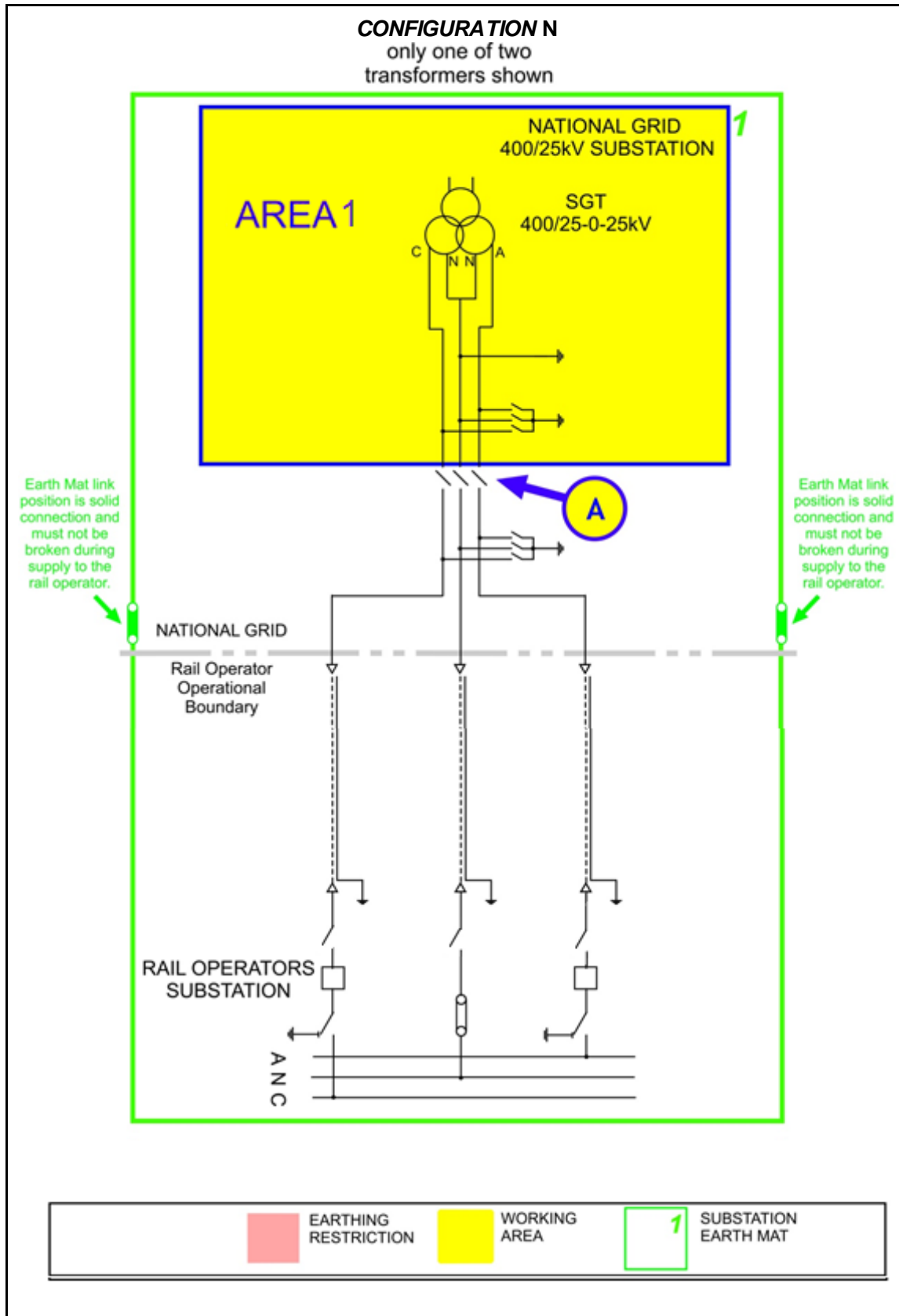

The following table is not a switching sequence. A **Senior Authorised Person** shall include the following tabulated precautions required on **Equipment** as part of a switching, isolating and earthing sequence to eliminate *ACR Current* from the designated working AREA.

AREA 1

Equipment	Precautions Required	Reason
Disconnecter A	Check open, lock and apply the "Do Not Close Notice"	Disconnect conductors connected to the Rail Operator's System to stop <i>ACR Current</i> flowing through the point of work via the <i>Pole</i> and <i>Neutral Conductors</i> .

NOTE: The earth mat links connecting the National Grid's earth mat to the Rail Operator's earth mat must not be removed during the operation of any supplying transformer.

CONFIGURATION N – AREA 2

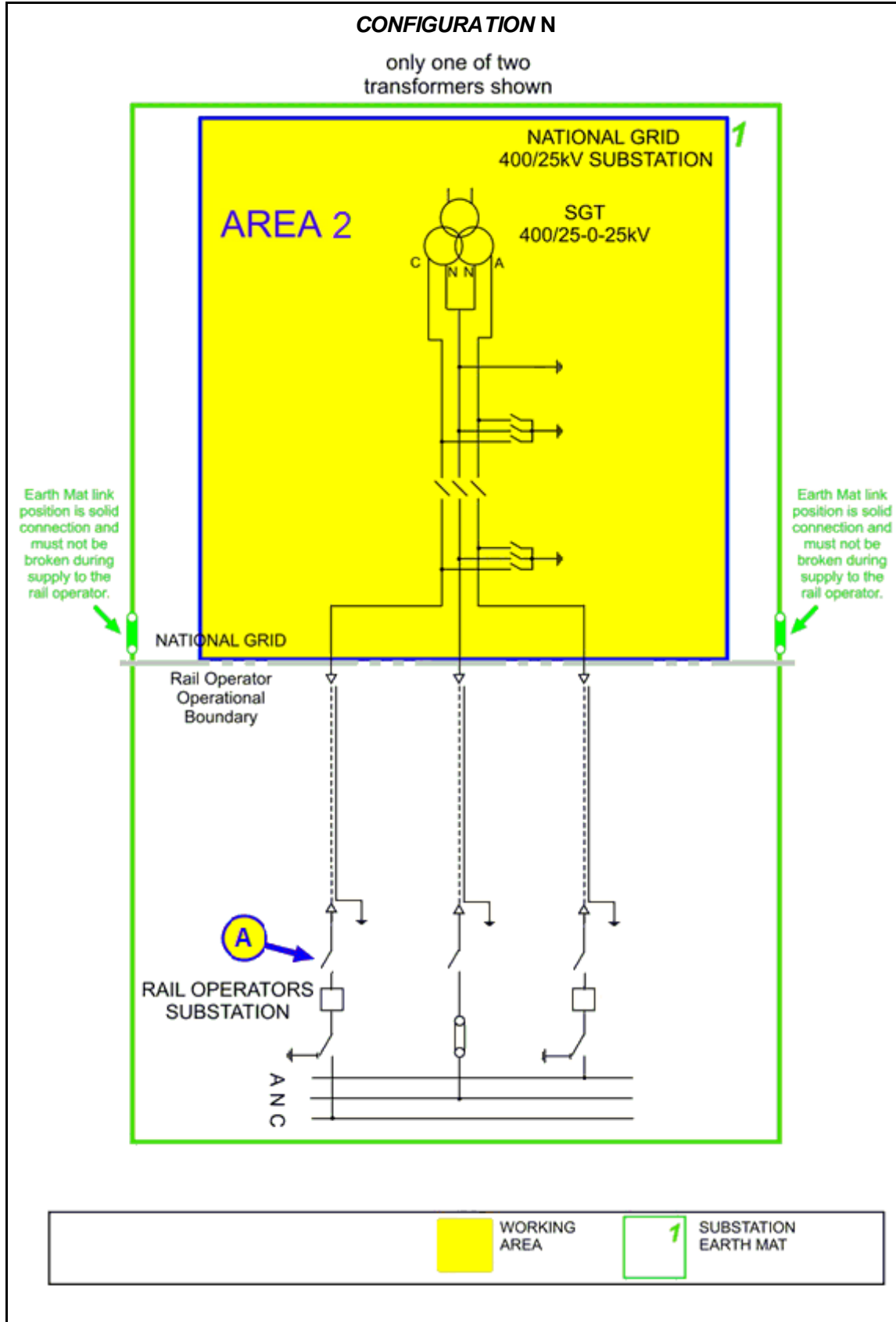

The following table is not a switching sequence. A **Senior Authorised Person** shall include the following tabulated precautions on **Equipment** as part of a switching, isolating and earthing sequence to eliminate *ACR Current* from the designated working AREA.

AREA 2

Equipment	Precautions Required	Reason
Rail Operators Equipment Disconnecter A.	Check, open, lock and apply the "Do Not Close Notice".	Disconnect conductors from 25kV substation and rail operators system to stop any ACR Current flowing through the point of work

NOTE: The earth mat links connecting the National Grid's earth mat to the Rail Operator's earth mat must not be removed during the operation of any supplying transformer.

CONFIGURATION P
CONFIGURATION P – AREA 1

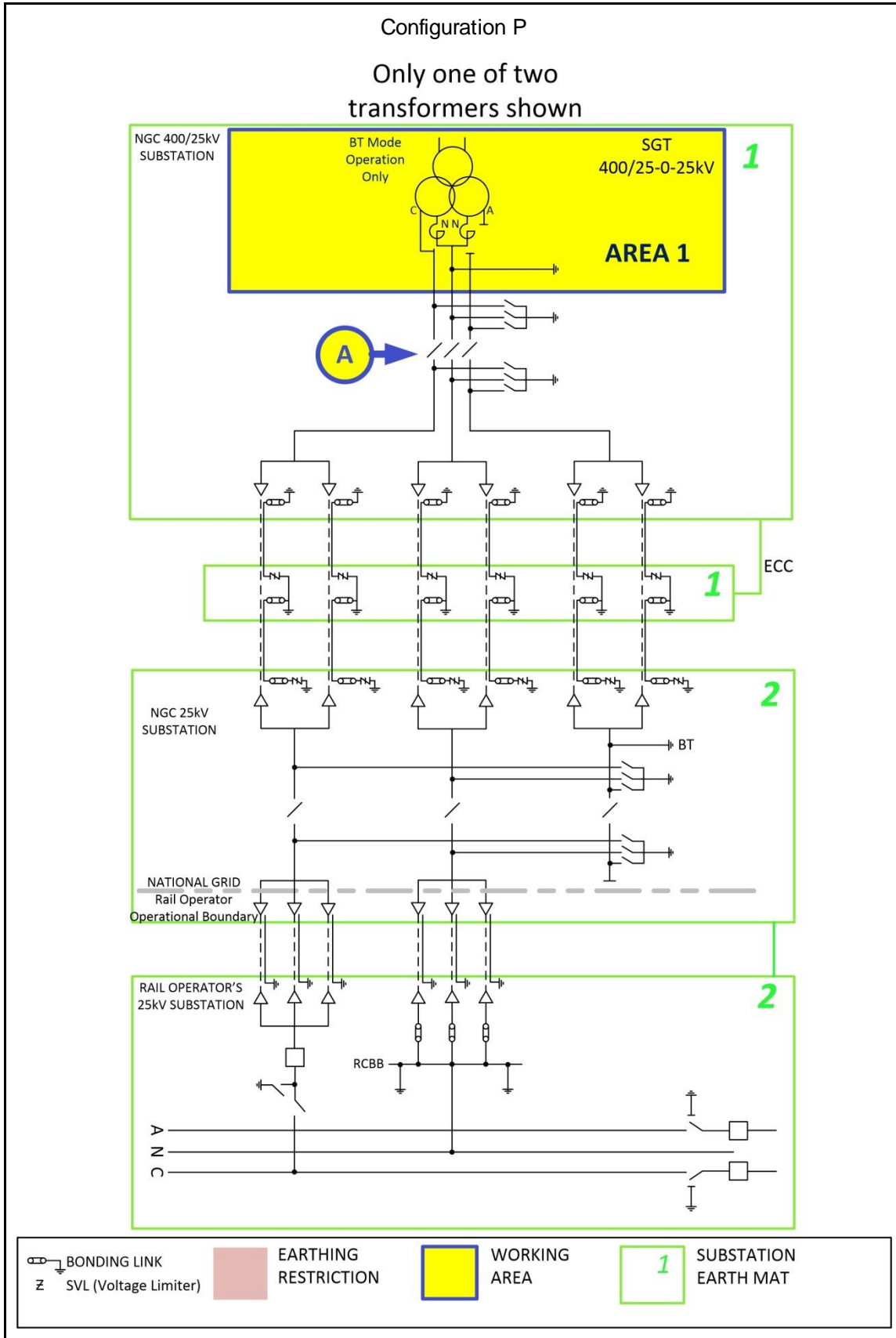

The following table is not a switching sequence. A **Senior Authorised Person** shall include the following tabulated precautions required on **Equipment** as part of a switching, isolating and earthing sequence to eliminate *ACR Current* from the designated working AREA.

AREA 1

Equipment	Precautions Required	Reason
Disconnecter A	Check open, lock and apply the "Do Not Close Notice"	Disconnect conductors connected to the Rail Operator's System to prevent <i>ACR Current</i> flowing through the point of work via the <i>Pole</i> and <i>Neutral Conductors</i> .

CONFIGURATION P – AREA 2A & 2B

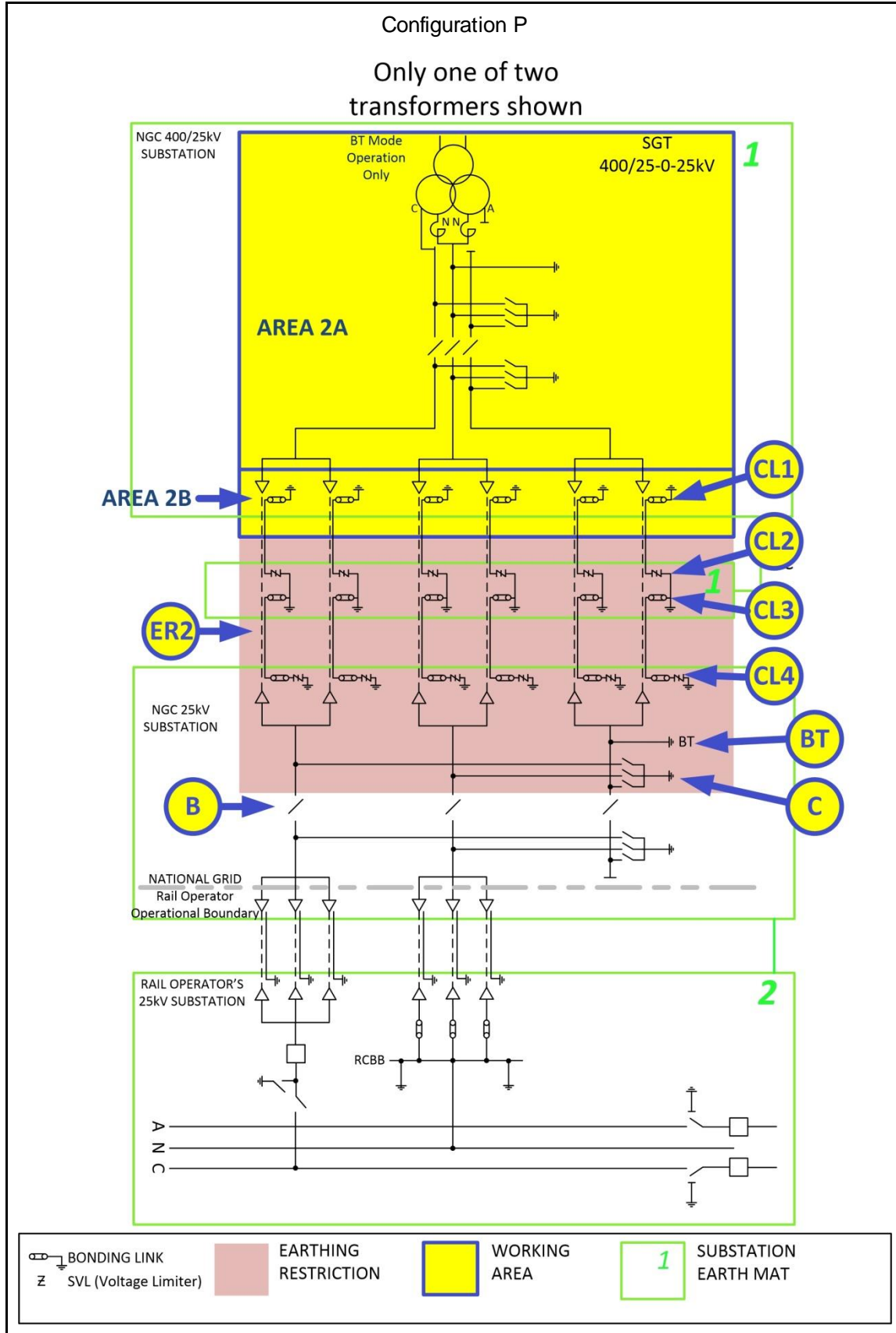

The following table is not a switching sequence. A **Senior Authorised Person** shall include the following tabulated precautions required on **Equipment** as part of a switching, isolating and earthing sequence to eliminate *ACR Current* from the designated working AREA.

AREA 2A

Equipment	Precautions Required	Reason
Disconnecter B	Check, open, lock and apply the "Do Not Close Notice"	Disconnect conductors from 25kV substation and rail operators system to stop <i>ACR Current</i> between earth mats via the <i>Pole</i> and <i>Neutral Conductors</i> .
Earth Switch C	Open Earth Switch C and apply the "Do Not Earth Conductors Notice"	This precaution is necessary as an earth on any <i>Pole Conductor</i> or <i>Neutral Conductor</i> will create a parallel path through which <i>ACR Current</i> will flow.
BT Conductor Earth, BT (if applicable)	Remove conductor earth, apply the "Do Not Earth Conductors Notice". A Permit will be required for this action.	Action is required to prevent <i>ACR Current</i> flowing along <i>A Pole</i> conductors when an earth is placed on the <i>A Pole</i> conductor in the working area. Additional precautions may be necessary to avoid the Dangers of induced voltages. This earth must be in place if the circuit is to be energised in permanent BT Mode.
Earth restriction region ER2	Do not apply earths on Equipment inside regions ER2.	This precaution is necessary as an earth on any <i>Pole Conductor</i> , <i>Neutral Conductor</i> or cable sheath will create a parallel path through which <i>ACR Current</i> will flow.

AREA 2B

If works are required on, or that could infringe the **Safety Distance** to, the cables, cable sealing ends or cable sheath connections then the following additional requirements to those for AREA 2A apply.

Cable sheath earth links CL2	Remove cable sheath SVLs. Apply the "Do Not Earth Conductors Notice".	These SVLs are to be removed in case they are not operating correctly. Removal of the SVLs from all cables will prevent <i>ACR Current</i> flowing between the earth mats along the cable sheaths. NOTE: The cable bonding links "CL1" at the solidly bonded position shall be removed prior to removing / replacing the SVLs at the "CL2" position. "CL1" shall not be quoted as an <i>ACR</i> precaution.
------------------------------	---	--

For guidance on the use of AREA 2B or AREA 3A refer to Section 4.3 of this document.

For multiple work locations on cables or their accessories refer to Section 8.1 of this document.

CONFIGURATION P – AREA 3A

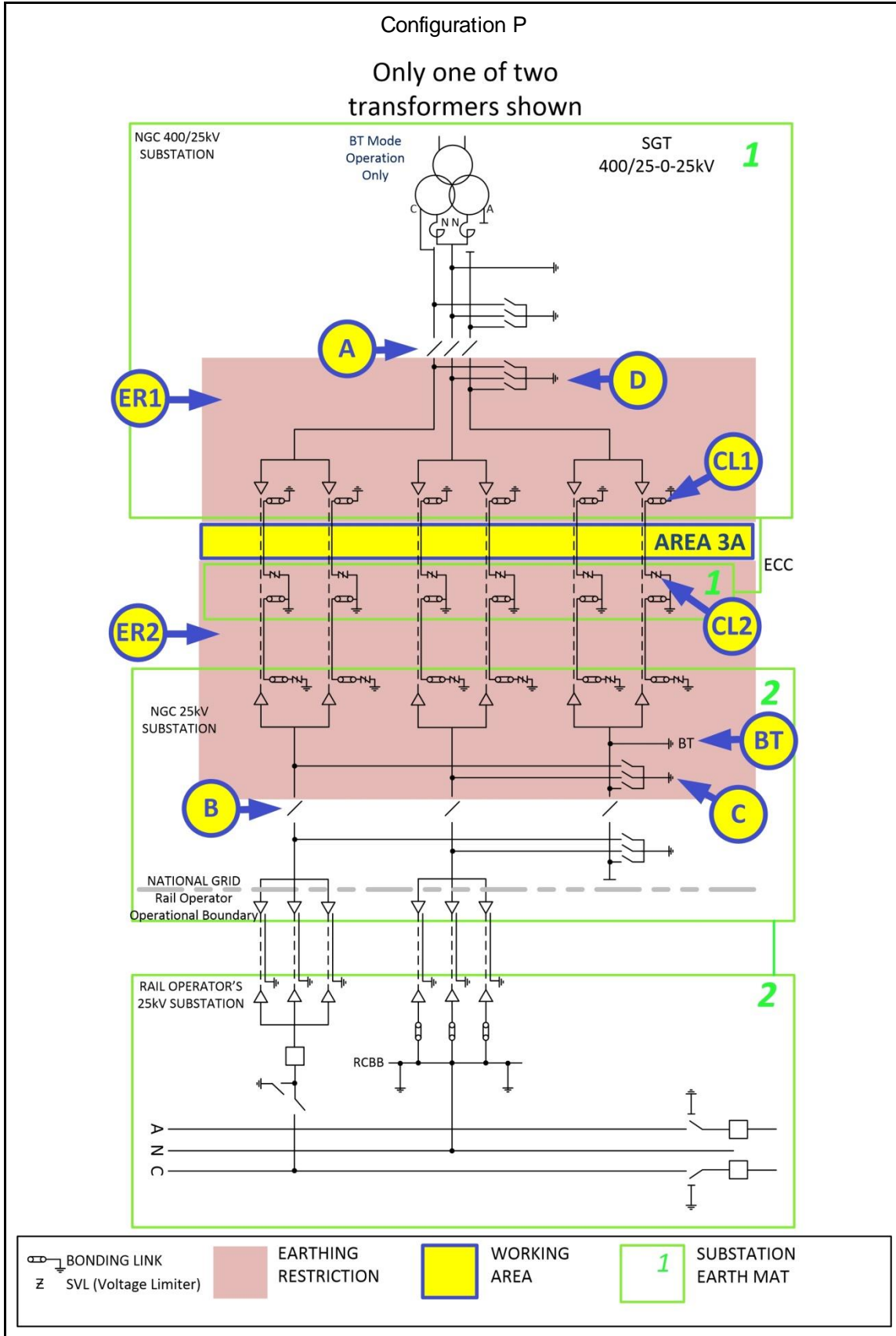

The following table is not a switching sequence. A **Senior Authorised Person** shall include the following tabulated precautions required on **Equipment** as part of a switching, isolating and earthing sequence to eliminate *ACR Current* from the designated working AREA.

AREA 3A

Equipment	Precautions Required	Reason
BT conductor earth, BT. (If applicable)	Remove conductor earth. Apply the "Do Not Earth Conductors" Notice. A Permit will be required for this action.	This precaution is to prevent <i>ACR Current</i> flowing along the <i>A Pole</i> conductors if an earth is placed on the <i>A Pole</i> cable conductor in Area 3A. Additional precautions may be necessary to avoid the Dangers of induced voltages.
Disconnectors A and B.	Check, open, lock and apply the "Do Not Close" Notice	To avoid <i>ACR Current</i> in conductors between the 25kV and 400kV substations from the rail operator's System .
Earth Switches C and D	Open Earth Switches and apply the "Do Not Earth Conductors" Notice.	This precaution is necessary to prevent <i>ACR Current</i> flowing along a cable conductor if a local earth is placed on the cable conductor in AREA 3A.
<i>Earthing restriction zones</i> ER1 and ER2.	Do not apply earths on Equipment inside regions ER1 and ER2.	This precaution is necessary to prevent <i>ACR Current</i> flowing along a cable conductor or cable sheath when an earth is placed on a cable's conductor or sheath in AREA 3A. The placing of an earth in the restricted regions ER1 and ER2 would create an alternative path for <i>ACR Current(s)</i> .
Cable sheath earth links CL1 and SVLs CL2.	Remove cable sheath earth and bonding links. Apply the "Do Not Earth Conductors" Notice.	The links at CL1 and the SVLs at CL2 are to be removed in case the SVLs are not operating correctly. Removal of the links and SVLs from all cables will prevent <i>ACR Current</i> flowing between the earth mats along the cable sheaths in Area 3A. The cable bonding links CL1 at the solidly bonded position shall be removed prior to removing the SVLs at CL2. This is to avoid <i>ACR Currents(s)</i> flowing along a cable sheath as a result of a direct connection to a station earth mat.

For guidance on the use of AREA 2B or AREA 3A refer to Section 4.3 of this document.

For multiple work locations on cables or their accessories refer to Section 8.1 of this document.

CONFIGURATION P – AREA 3B

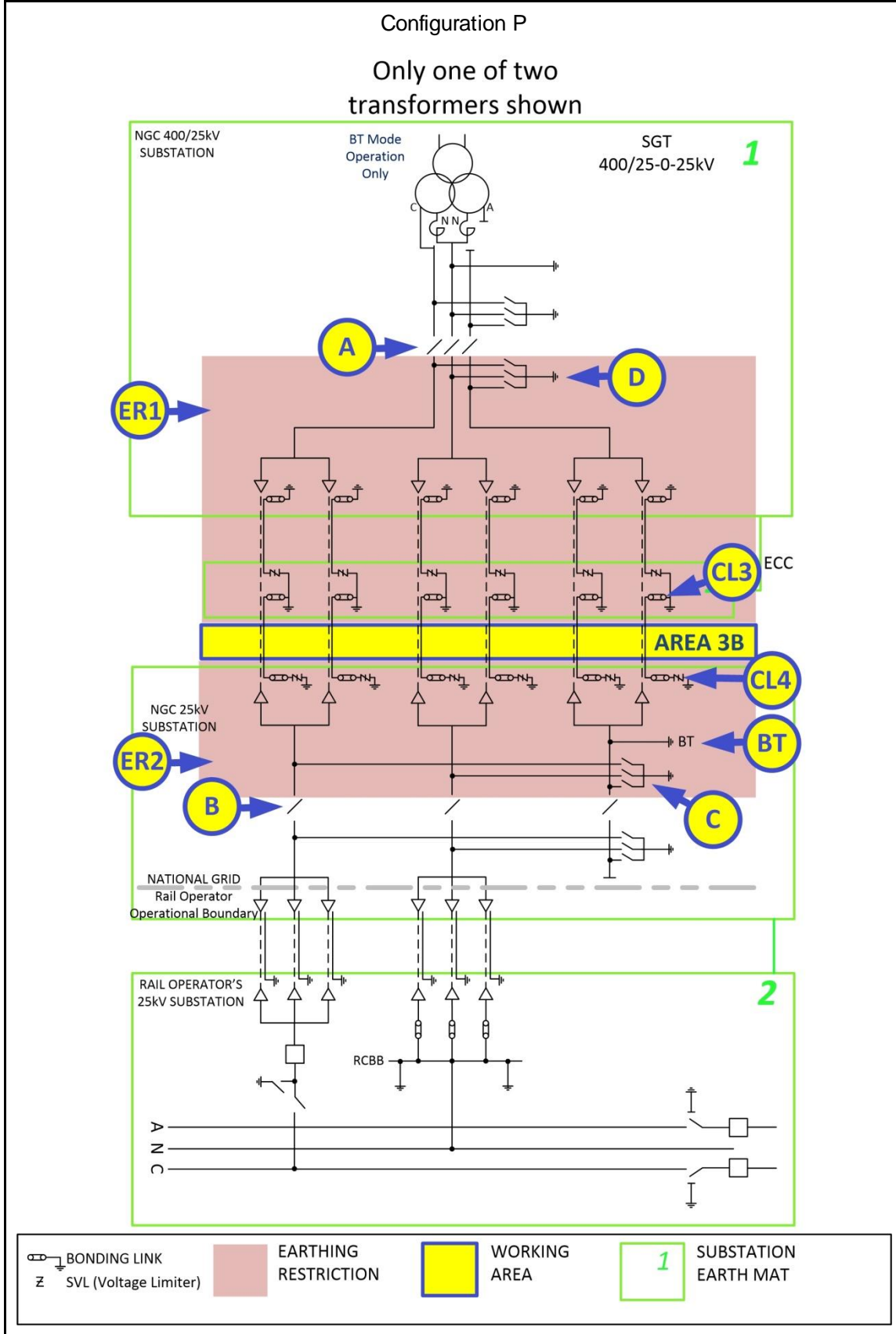

The following table is not a switching sequence. A **Senior Authorised Person** shall include the following tabulated precautions required on **Equipment** as part of a switching, isolating and earthing sequence to eliminate *ACR Current* from the designated working AREA.

AREA 3B

Equipment	Precautions Required	Reason
BT conductor earth, BT. (If applicable)	Remove conductor earth. Apply the "Do Not Earth Conductors" Notice. A Permit will be required for this action.	This precaution is to prevent <i>ACR Current</i> flowing along the <i>A Pole</i> conductors if an earth is placed on the <i>A Pole</i> cable conductor in Area 3B. Additional precautions may be necessary to avoid the Dangers of induced voltages.
Disconnectors A and B.	Check, open, lock and apply the "Do Not Close" Notice	To avoid <i>ACR Current</i> in conductors between the 25kV and 400kV substations from the rail operator's System .
Earth Switches C and D	Open Earth Switches and apply the "Do Not Earth Conductors" Notice.	This precaution is necessary to prevent <i>ACR Current</i> flowing along a cable conductor if a local earth is placed on the cable conductor in AREA 3B.
<i>Earthing restriction zones</i> ER1 and ER2.	Do not apply earths on Equipment inside regions ER1 and ER2.	This precaution is necessary to prevent <i>ACR Current</i> flowing along a cable conductor or cable sheath when an earth is placed on a cable's conductor or sheath in AREA 3B. The placing of an earth in the restricted regions ER1 and ER2 would create an alternative path for <i>ACR Current(s)</i> .
Cable sheath earth links at CL3 and SVLs at CL4.	Remove cable sheath earth and bonding links. Apply the "Do Not Earth Conductors" Notice.	These links are to be removed in case the SVLs are not operating correctly. Removal of the links from all cables will prevent <i>ACR Current</i> flowing between the earth mats along the cable sheaths. The cable bonding links "CL3" at the solidly bonded position shall be removed prior to removing the SVL at "CL4" position. This is to avoid <i>ACR Currents(s)</i> flowing along a cable sheath as a result of a direct connection to a station earth mat.

For guidance on the use of AREA 4B or AREA 3B refer to Section 4.3 of this document.

For multiple work locations on cables or their accessories refer to Section 8.1 of this document.

CONFIGURATION P – AREA 15

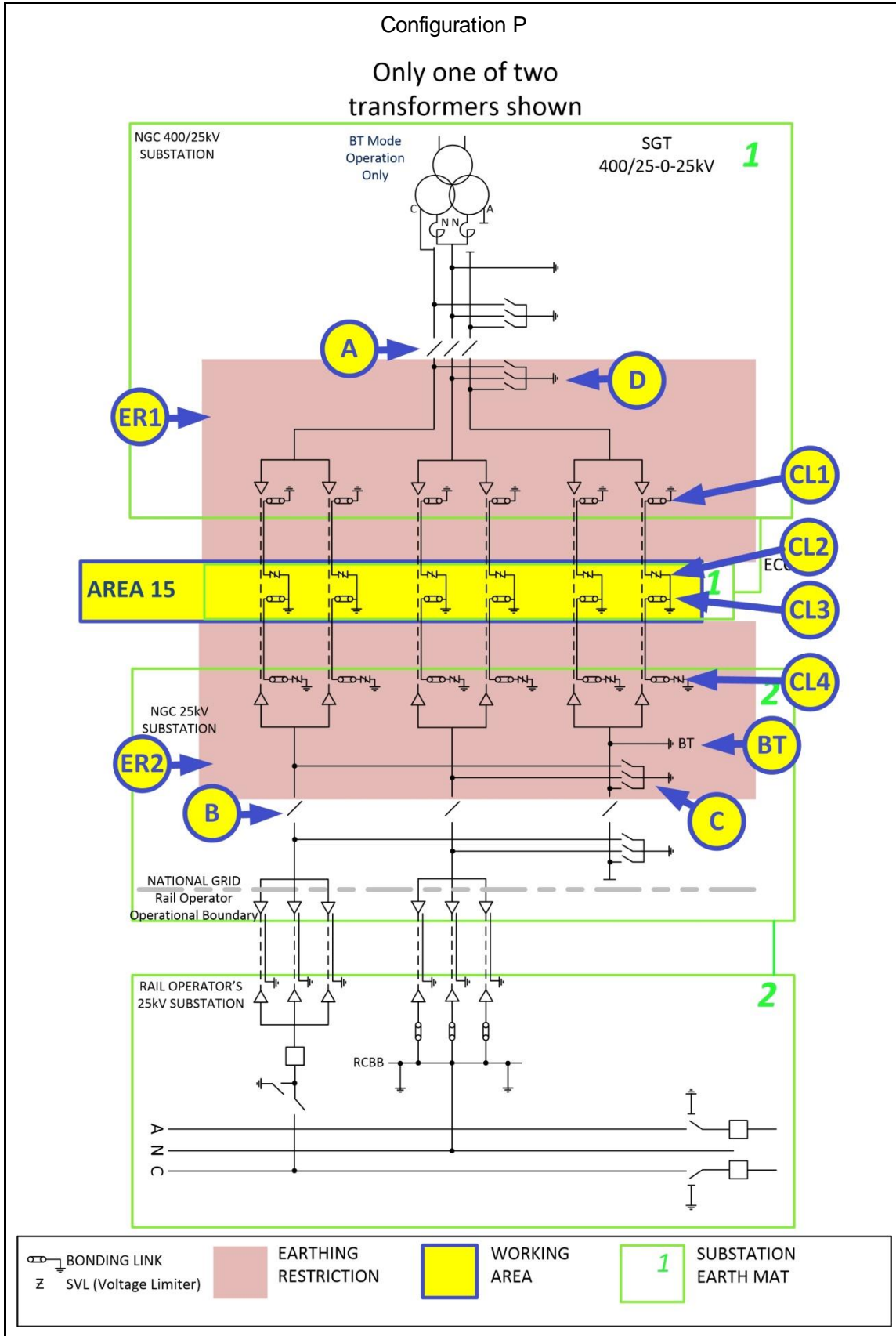

The following table is not a switching sequence. A **Senior Authorised Person** shall include the following tabulated precautions required on **Equipment** as part of a switching, isolating and earthing sequence to eliminate *ACR Current* from the designated working AREA.

AREA 15

Equipment	Precautions Required	Reason
BT conductor earth, BT. (If applicable)	Remove conductor earth. Apply the "Do Not Earth Conductors" Notice. A Permit will be required for this action.	This precaution is to prevent <i>ACR Current</i> flowing along the <i>A Pole</i> conductors if an earth is placed on the <i>A Pole</i> cable conductor in Area 15. Additional precautions may be necessary to avoid the Dangers of induced voltages.
Disconnectors A and B.	Check, open, lock and apply the "Do Not Close" Notice	To avoid <i>ACR Current</i> in conductors between the 25kV and 400kV substations from the rail operator's System .
Earth Switches C and D	Open Earth Switches and apply the "Do Not Earth Conductors" Notice.	This precaution is necessary to prevent <i>ACR Current</i> flowing along a cable conductor if a local earth is placed on the cable conductor in AREA 15.
<i>Earthing restriction zones</i> ER1 and ER2.	Do not apply earths on Equipment inside regions ER1 and ER2.	This precaution is necessary to prevent <i>ACR Current</i> flowing along a cable conductor or cable sheath when an earth is placed on a cable's conductor or sheath in AREA 15. The placing of an earth in the restricted regions ER1 and ER2 would create an alternative path for <i>ACR Current(s)</i> .
Cable sheath earth links at CL1 and CL4.	Remove cable sheath earth and bonding links. Apply the "Do Not Earth Conductors" Notice.	Removal of the links from all cables will prevent <i>ACR Current</i> flowing between the earth mats along the cable sheaths. This is to avoid <i>ACR Currents(s)</i> flowing along a cable sheath as a result of a direct connection to a station earth mat. NOTE: The cable bonding links "CL1" and "CL3" at the solidly bonded positions shall be removed prior to removing / replacing the SVLs at the "CL2" and "CL4" positions. "CL2" and "CL3" shall not be quoted as a <i>ACR</i> precautions.

For guidance on the use of AREA 3A, Area 3B or AREA 15 refer to section 4.3 of this document.

For multiple work locations on cables or their accessories refer to Section 8.1 of this document.

CONFIGURATION P – AREA 4A & 4B

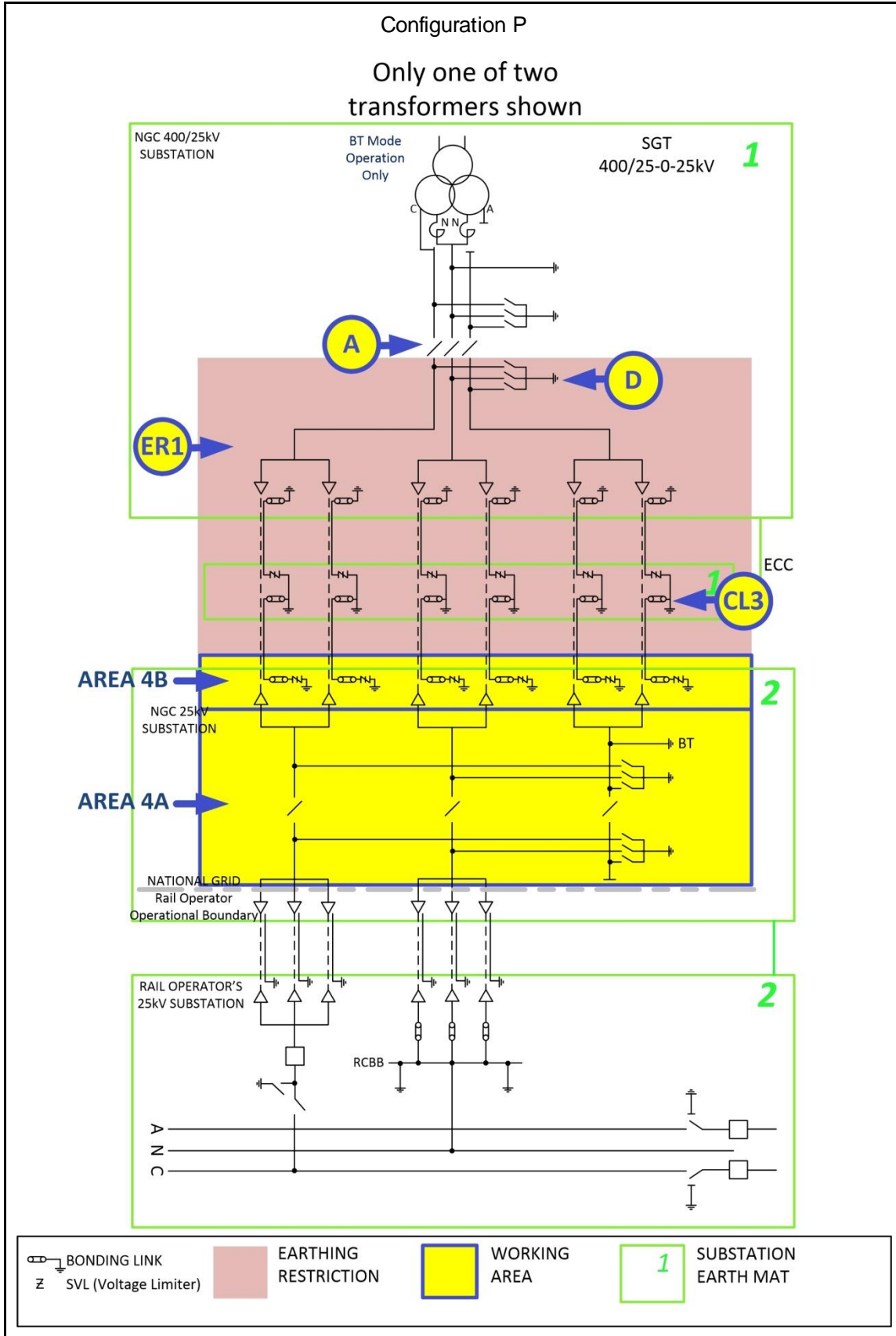

The following table is not a switching sequence. A **Senior Authorised Person** shall include the following tabulated precautions required on **Equipment** as part of a switching, isolating and earthing sequence to eliminate *ACR Current* from the designated working AREA.

AREA 4A

Equipment	Precautions Required	Reason
Disconnecter A.	Check, open, lock and apply the "Do Not Close" Notice	Avoid ACR Current in conductors between the 25kV and 400kV substations from the rail operator's System.
Earth Switch D.	Open Earth Switches and apply the "Do Not Earth Conductors" Notice.	This precaution is necessary to prevent ACR Current flowing along any conductor which is earthed in the work area.
<i>Earthing restriction zone</i> ER1.	Do not apply earths on Equipment inside region ER1.	This precaution is necessary to avoid ACR Current flowing along conductors when an earth is placed on a conductor in the work area

AREA 4B

If works are required on, or that could infringe the **Safety Distance** to, the cables, cable sealing ends or cable sheath connections then the following additional requirements to those for AREA 4A apply.

Cable sheath earth links, CL3	Remove cable sheath earth and bonding links. Apply the "Do Not Earth Conductors" Notice.	Removal of the links from all cables will prevent <i>ACR Current</i> flowing between the earth mats along the cable sheaths.
-------------------------------	--	--

For guidance on the use of AREA 4B or AREA 3B refer to Section 4.3 of this document.

For multiple work locations on cables or their accessories refer to Section 8.1 of this document.

APPENDIX D - AUTHORISATION MATRIX FOR CONTRACTORS PERSONNEL

Contractors appointment under this NSI shall be limited to the following sections.

Contractor Personnel	Person	Competent Person	Authorised Person	Senior Authorised Person
Sections	N/A	N/A	N/A	N/A