

**Power Potential
Market Procedures**

Issued on 2 August 2018

Website:

www.nationalgrid.com/powerpotential

For information, please contact:

box.PowerPotential1@nationalgrid.com

IMPORTANT – PLEASE READ

Introduction

These Market Procedures are to be read in conjunction with the following documentation, which is available on National Grid's website via:

<https://www.nationalgrid.com/uk/investment-and-innovation/innovation/system-operator-innovation/power-potential>

- ▶ Power Potential DER Framework Agreement – the contract between UK Power Networks and Power Potential market participants

Disclaimer and Provider's Responsibility

The information supplied with, contained in, or referred to in the Documentation, and all other information relating to Power Potential, and any contract whereby Power Potential may be made available to, and provided to the Provider, which is provided by UK Power Networks at any time, whether before or after the date hereof, is given in good faith. However, no warranty or representation or other obligation or commitment of any kind is given by UK Power Networks, its employees or advisors as to the accuracy or completeness of any such information or that there are not matters material to the arrangements and matters referred to therein other than is contained or referred to in such information. Neither UK Power Networks nor its employees or advisors shall be under any liability for any error or misstatement or as a result of any failure to comment on any information provided by UK Power Networks or the recipient of the Documentation or any other person or any answers to any questions or for any omission and none of such information shall constitute a contract or part of a contract.

Providers for Power Potential shall satisfy themselves of the accuracy and completeness of any information they may use in preparing their Tenders whether such information is provided by UK Power Networks or comes from any other source. UK Power Networks, its advisors and any other person responsible for production of any information to a Provider do not accept any duty of care to the Provider. It is the duty and responsibility of a Provider to ensure that it takes into account all considerations relating to the Tender and the entering into a Power Potential DER Framework Agreement.

UK Power Networks reserves the right not to proceed with any tenders or proposals made in response to the Documentation.

Version control

Version	Date published	Comments
2.0	01/08/2018	

Table of Contents

- 1 Background and high level summary 4**
- 2 Structure of the trial 6**
 - 2.1 Introduction and overview 6
 - 2.1.1 Reactive Power service 6
 - 2.1.2 Active Power service 7
- 3 How to participate..... 8**
 - 3.1 Overview 8
 - 3.2 DER commissioning testing..... 8
 - 3.3 Reactive Power Service 10
 - 3.3.1 Wave 1 participation..... 10
 - 3.3.2 Wave 2 13
 - 3.3.3 Wave 3 18
 - 3.4 Active Power Service..... 19
 - 3.4.1 Mandatory Technical Trials 19
 - 3.4.2 Active Power – Competitive Bidding..... 19
- 4 Market reporting..... 21**
- 5 APPENDIX 1 – Market Trial Calendar 22**
- 6 APPENDIX 2 – DUoS charges related to Power Potential 24**

1 Background and high level summary

This document provides current and future Power Potential Service Providers with clear, simple and transparent guidance on the services. It is a live document, which may change throughout the course of the Power Potential project. It is intended to help potential Providers understand how the tendering process will work in practice.

Power Potential (originally named Transmission Distribution Interface 2.0) is a Network Innovation Competition project that represents a collaboration between National Grid (System Operator) and UK Power Networks (Distribution Network Operator). The trial, which is running in the South East of England, is intended to explore the use of Distributed Energy Resources (DER) to provide dynamic voltage support and constraint management services to the System Operator (SO), and to do so:

- ▶ **Efficiently** – identifying and dispatching DER able to deliver the service at the lowest cost to the SO, accounting for price and effectiveness,
- ▶ **Reliably** – ensuring that services produced by DER contribute to constraint resolution in a consistent and predictable manner, and
- ▶ **Securely** – ensuring that action to manage constraints on the transmission network do not create issues on the distribution network.

The trial is exploring the provision of reactive and active power services while investigating both the technical and commercial aspects of DER participation. It is designed to mimic the real-world situation in which a change in reactive and/or active power flows are required on the distribution network in order to manage voltage or thermal constraints on the transmission network.

A Distributed Energy Resources Management System (DERMS) is being developed as part of the project. The DERMS Web Interface will provide DER with a web portal to communicate its interest in participating. This system, which will be hosted and operated by UK Power Networks, acts as the intermediary between National Grid and participating DER. At a high level, the process is as follows:

Reactive Power Service

1. Ahead of time a DER submits a PQ capability chart (either upon commissioning or subsequently updated) indicating, for a given active power output (expressed in MW), the range of reactive power that is made available (expressed in MVar,) and when the reactive power service is offered
2. By 14:00 on the day ahead of the trading day, via the DERMS Web Interface, DER provide:
 - i. expected operating level (expressed in MW) together with its reactive power range for each Service Window (s) for which they wish to bid,
 - ii. the price at which they wish to offer availability and utilisation.
3. The DERMS collates this information for each Grid Supply Point (GSP), taking into account the effectiveness of each DER at the GSP (see section 3.3.2 for more detail on 'effectiveness'), expected active and reactive power operating points and their bid, and passes this information to National Grid as the total volume and the cost to procure this volume
4. In the case of the Reactive Power service, National Grid procures, through the DERMS, an availability volume in line with its requirement (subject to prices), which

will be confirmed to DER via their web-interface and for which DER will receive availability payments (subject to compliance). During settlement day, the DERMS can then dispatch DER in response to a request from National Grid. DER must also respond automatically to network events, delivering dynamic voltage control when needed.

5. The DERMS monitors DER response to verify performance, and records the necessary data for subsequent settlement and payment.

Active Power Service

1. By 14:00 on the day ahead of the trading day, via the DERMS Web Interface, DER provide:
 - i. maximum and minimum power parameters and the expected output levels (expressed in MW)
 - ii. the utilisation price at which they wish to offer the Active Power service
2. The DERMS collates this information for each Grid Supply Point (GSP) and passes this information to National Grid as the total volume and the cost to dispatch this volume
3. The DERMS monitors DER response to verify performance, and records the necessary data for subsequent settlement and payment.

The Trial phase of the Power Potential project is planned to commence early in 2019 and to run until the end of the year.

2 Structure of the trial

2.1 Introduction and overview

The project aims to trial both technical and commercial aspects of the Power Potential services. It is intended to ensure that trial participants receive adequate compensation for their involvement, whilst also encouraging market bidding that mimics real-world behaviour. DER have the option to participate in one or both of the services.

2.1.1 Reactive Power service

In order to achieve these objectives, the Reactive Service component of the trial will be split into three “waves”. Before participating in the waves, Participants must complete a Mandatory Technical Trial (see section 3.3.1.1 Eligibility and timings).

- ▶ Wave 1 is predominantly aiming to trial the technical aspects of the Power Potential services and, through the trial, to allow participants to recover most of their upgrade costs. The Wave 1 Trial is split to allow technical trials that cover a range of network configurations and operating conditions. Before participating in the Wave 1 trial, Participants must complete a Mandatory Technical Trial.
- ▶ Wave 2 introduces competitive bidding between DER, with the volumes accepted by National Grid in line with actual system need, although volumes procured will not be used to secure the system.
- ▶ Wave 3 brings DER into competition with other market-based options available to National Grid. Only DER that are as cost-effective as other options will be accepted. DER will be competing with transmission-connected assets where multiple parties at multiple connection levels can fulfil a requirement. National Grid is entitled to secure the system using DER services during this wave.

Reactive Service payments for DER will include:

- ▶ Participation Payments (linked to overall availability in Wave 1 of the trials), and
- ▶ Market Revenues (from payments for availability and utilisation during Waves 2 and 3).

An overview of the key features of each Reactive Power trial wave is as follows:

Table 1 Reactive Power trial structure

Wave	Funding from	Participation payment	Availability payment policy	Utilisation payment policy
1	Project budget	Up to [£45,000] per site, linked to availability ¹	No payments	No payments
2	Project budget	N/A	Driven by market bids	Driven by market bids
3	National Grid budget	N/A	Assessed in line with other market based options	

¹ See section 3.3.1 for details of the availability assessment

2.1.2 Active Power service

To participate in the Active Power Service, DER must first complete a Mandatory Technical Trial. A fixed fee of £150/MWh will be paid for any MWh dispatched to validate the DER response to an active power set-point instruction before moving to competitive bidding. This will take place during the first 2 weeks² of the trial during which each DER is expected to be available for one day for its individual testing during the time windows that are agreed with the project team (see Mandatory Technical Trials). During competitive bidding, DER payments will be made at the level of DER bids ('pay-as-bid'), and there will be no availability payment for the active power service.

² Any DER who joins the trial after the first two weeks must complete a Mandatory Technical Trial before being able to offer competitive bids for Active Power Response

3 How to participate

3.1 Overview

The flowchart in Figure 1 outlines the process for competitive bidding (i.e. Wave 2 and 3 for the reactive power service and competitive bidding following the Mandatory Technical Trials for the active power service). Note that Wave 1 for the reactive power service differs for some of these steps.

Figure 1 Power Potential bidding flowchart

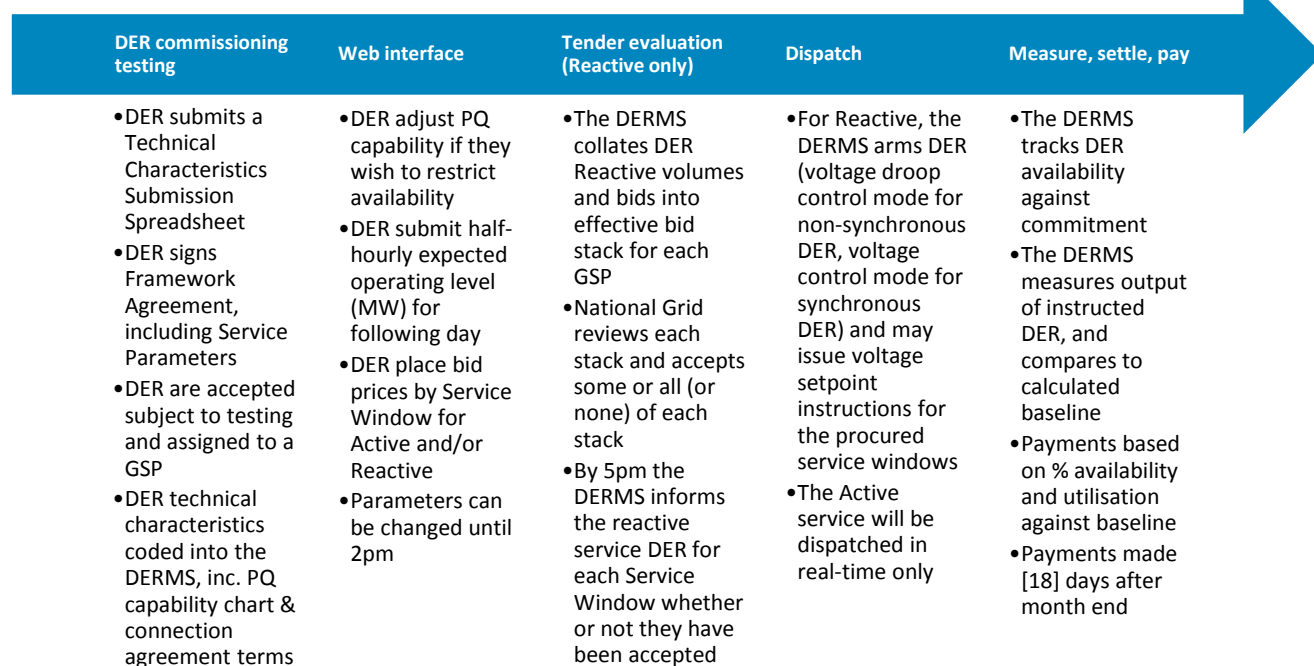

3.2 DER commissioning testing

All Power Potential Providers will need to sign a Power Potential DER Framework Agreement with UK Power Networks. This agreement includes technical characteristics of the Provider, which the Power Potential team will confirm makes the Provider eligible to participate once they have gone through the commissioning stage. The Framework Agreement, DER commissioning details and technical requirements can be found here:

www.nationalgrid.com/powerpotential

At a high level, the requirements for potential DER Providers are given in sections 3.2.1.1 and 3.2.1.2.

3.2.1.1 Active Power service

The Active Power service relates to the active power generated from the participating DER unit. After receiving an instruction, it will need to be capable of responding by automatically ramping the active power generated up and/or down according to the DERMS instruction and within the plant limitations. This service is expected to manage transmission constraints and

to support technical and commercial optimisation and dispatch. It will be exercised on the day in real-time depending on the cost compared to other options available to the System Operator.

The provision of this service means that the plant should be ready to change its active power output upon an instruction from UK Power Networks via the DERMS. The plants response should be automatic and within its pre-defined limits and ramp rates.

3.2.1.2 Reactive Power service

The Reactive Power service relates to the reactive power generated or absorbed by the participating DER plant. This production/absorption of reactive power could allow more effective control of the voltage in the transmission system.

The Reactive service is initiated by the DERMS issuing instructions to DER at the start of each Service Window for which DER was contracted, to change its operating mode (where necessary):

- ▶ for a non-synchronous contracted DER unit, to operate in voltage droop control mode; or
- ▶ for a synchronous contracted DER unit, to operate in voltage control mode

When in these control modes, DER will automatically respond to voltage changes measured at the DER Connection Point. In addition to this, a National Grid instruction via the DERMS would translate into a change of DER voltage set-point to achieve National Grid's request. In either case, the response would be achieved within 2-5 seconds, as per service requirements. Otherwise, the DER would be kept operating at their default operating level and the DERMS would adjust DER voltage set-points if needed to keep a unit's reactive power output as close to its default value as possible.

3.3 Reactive Power Service

3.3.1 Wave 1 participation

3.3.1.1 Eligibility and timings

All participants who sign up to the DER Framework Agreement will be eligible to participate in Wave 1 subject to passing the DER Commissioning Test.

Wave 1 is planned to commence early in 2019 – the date will be confirmed towards the end of 2018 (see indicative Market Trial Calendar in Appendix 1. The Wave will incorporate both Mandatory Technical Trials and Optional Technical Trials. It will be split into phases in order to allow technical trials to explore different network conditions. The final Market Trial Calendar will be published 30 days before the actual trial commencement date.

Before a DER can participate in the Optional Technical Trials (which Participation Payments are linked to, see below) it must first complete a period of Mandatory Technical Trials (for which no payments are to be made to DER). Mandatory Technical Trials will be carried out during the first two weeks of the Optional Technical Trials, with trial windows between two and ten hours in length across two days, the timing of which will be agreed with DER³.

There are some steps to participate in the Mandatory Technical Trials:

1. As part of submission of their Technical Characteristics Submission Spreadsheet, DER will have submitted their PQ capability chart (see Figure 2), and UKPN will discuss with the DER any limitations on this related to the Connection Agreement for the site. The combined PQ capability chart forms Schedule 3 of the Framework Agreement, and will have been verified through commissioning testing.
2. Before each set of Optional Technical Trials, DER will be required to submit their hours of availability for Reactive power for the whole of that period. These availabilities could be amended⁴ if the DER expectations change during this time.

Figure 2 Illustration of reactive and active service availability via PQ capability chart

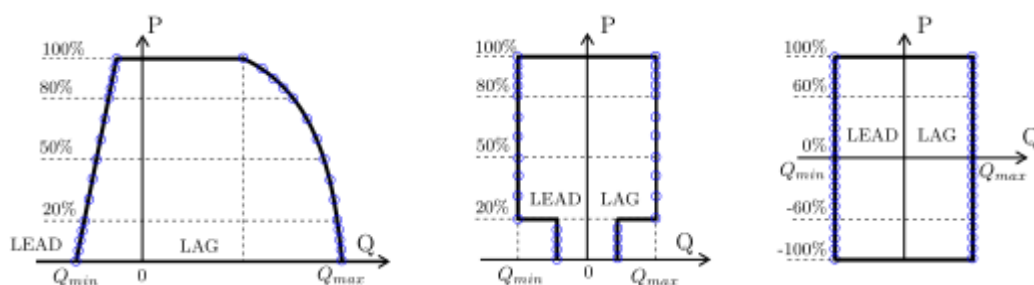

³ DER that cannot carry out Mandatory Technical Trials in the first two weeks of the trial will not be able to offer availability for Optional Technical Trials until they have completed their Mandatory Technical Trials. We will work with DER to schedule these as soon as possible to maximise a DER chances of maximising their Participation Payments for Optional Technical Trial.

⁴ Meaning that the DER could opt out/in of the Reactive Power service. Availability definition is covered in the next Settlement and Payment section of this document and refers to the DER capability to provide the service not to the reactive range available.

Submission of availability for the Reactive Power Optional Technical Trials will be done through the DERMS Web Interface.

For each trial day, by 2pm the day before, DER will be required to provide a half-hourly forecast of their Active power expected operating levels. This information will not be acted upon in Wave 1 but will be used as a learning, both for the DER and the Power Potential project, to prepare for Wave 2.

Wave 1 Optional Technical Trials are expected to cover approximately 2,520 hours of the total number of hours during the trial period.

DER will not be paid for availability or utilisation during Wave 1. Instead, they will receive a Participation Payment based on their availability. Utilisation during this period will not exceed 250 hours. For a DER with an absolute MVar range of 'y' MVars, utilisation during this period will not exceed 250'y' MVarh (i.e. MVar range x 250 hours). If a DER makes itself available for all 2,520 hours, therefore, it can expect to be utilised in only 10% of those hours. Further details can be found in Trial Calendar (Appendix 1), which will be confirmed and published 30 days prior to trial commencement.

DER must be available for a minimum of 700 hours to recover the minimum payment. Participation Payments will be made in based on the number of hours DER are available for during the 2,520 hours, as per Table 2 in section 3.3.1.3.

For a DER to be deemed available during Wave 1 (mandatory and optional), it must:

1. Indicate whether it is available for each Settlement Period via the DERMS Web Interface,
2. Offer the full Q range that it is capable of doing so for a given MW output level (in accordance with their submitted PQ capability chart and network connection agreement limits), and
3. Be able to provide a non-zero volume of Reactive Power, as indicated by the PQ capability chart and the DERMS measurement of active output.

3.3.1.2 Participation process

For the reactive power service, Wave 1 Optional Technical Trials will take place after the Mandatory Technical trials and will be spread out during 2019 to gather data from a range of operating conditions and network configurations. They are each expected to run consecutively for a fixed number of weeks, with 24 hour availability windows. DER who are not available during these windows will be paid on the basis of the hours for which they are available (see section 3.3.1.3 for details), with the minimum number of hours being 700 to receive payment.

3.3.1.3 Settlement and Payment

Wave 1 optional trials will provide 2,520 hours of opportunity for DER to be available. Every hour they are available will contribute towards their participation payment. Participation Payments will be made in line with the monthly settlement process where the cumulative number of hours a DER was available for will be calculated and settled for accordingly, in line with Table 2 below.

Where a DER has already received payment in a previous month, additional payments will only be made to reflect the additional hours the DER were available for but have not yet been

compensated. For example, if a DER achieves 700 hours of availability over month 1 and 2, they will receive £36,000 through the month 2 payment process. If by the end of month 3 they have cumulatively been available for 1000 hours (including month 1-2 availability) they will receive an additional £2,000 (£38,000 minus £36,000) through the month 3 payment process.

Table 2 Optional Technical Trials Availability Thresholds

Amount recoverable	Availability hours
£36,000	$\geq 700, < 1,000$
£38,000	$\geq 1,000, < 1,300$
£41,000	$\geq 1,300, < 1,500$
£43,000	$\geq 1,500, < 1,850$
£45,000	$\geq 1,850$

For the purpose of determining hours achieved, a DER Unit will be deemed to have been available for each Settlement Period:

- ▶ If non-synchronous, when it is online with an active communications link as indicated by the DERMS Monitoring, in voltage droop control mode, and has submitted to the DERMS Web Interface an Expected Operating Level for active power (which could be zero, but for which the associated reactive power volume available would be non-zero.).
- ▶ If synchronous, when it is online with an active communications link as indicated by the DERMS Monitoring, in voltage control mode, and has submitted to the DERMS Web Interface an Expected Operating Level for active power (which could be zero, but for which the associated reactive power volume available would be non-zero).

For the purpose of determining Reactive Power Availability in Wave 1 Optional Technical Trials, a Provider is expected to offer its full range of Reactive Power Availability for each active power operating level, consistent with the performance test at site commissioning.

3.3.1.4 Trial GO / NO GO decision

Whilst it is expected that the Power Potential trial will proceed as planned, the Project Steering Committee may deem it necessary to halt the project if it cannot deliver on its core objectives. With respect to DER participation, this decision would focus on two indicators:

1. **Sufficient participation**, defined as having at least 7 participants signed up to the project
2. **Sufficient effect**, defined as expecting to see at least 40MVar of Reactive Power availability across the GSPs.

The project will also consider business readiness to deliver the Trial and the readiness of the technical solution.

From a technical perspective, we track detailed progress of the overall build and test of the DERMS solution and its system integration, and we will use our mailing list to inform our stakeholders, including participating DER, of the technical progress.

We will follow a staged approach to inform DER of the project's progress, including development of the DERMS and as a minimum, reporting on the following development stages:

1. all DERMS build strands are complete for one GSP by **01/11/18**
2. the 'Factory/System Acceptance Test' (FAT/SAT) for the DERMS solution is complete i.e. the system is working for one GSP in UKPN's cloud-based test environment by **05/12/18**
3. the first 'Site Integration Test' (SIT) for the solution is complete i.e. end-to-end system test on a pre-production environment by **25/01/19**
4. the 'Operational Acceptance Test' (OAT) for the solution is complete on our live systems **25th Feb 19**, shortly before the two week period for Mandatory Technical Trials beginning by **08/03/19**

Expected dates for these are also included in APPENDIX 1 – Market Trial Calendar.

If any of these criteria are not met, the Steering Committee may decide not to start the trial.

The project's formal "GO / NO GO" decision will be made at the end of January 2019, with reference to the DER participation and Site Integration Test criteria above (alongside business readiness). This will be our 'GO' decision to confirm the start of Trials (alongside business and customer readiness), and we expect this to be 6 weeks before the Mandatory Technical Trials begin.

In the event that the Power Potential trial does not go ahead, if Providers have successfully commissioned, they will be eligible for compensation for direct costs incurred up to 100% of the total Participation Payment. Compensation will be calculated on an open book basis, and Providers will be asked to produce evidence of costs incurred for upgrades required as a direct result of intending to participate in the Power Potential trials. Once the level of compensation has been agreed, DER will need to invoice UK Power Networks in order to receive payment.

3.3.2 Wave 2

3.3.2.1 Participation process

DER must have completed the Mandatory Technical Trials to participate in Wave 2. The process for participation in Wave 2 is similar to that for Wave 1, with the key difference being that this Wave introduces competition among participants, with each specifying both an availability price and a utilisation price. Therefore, the situation may arise where DER might have made themselves available but, depending on the combination of bid prices and effectiveness, would not be selected by the DERMS when it receives service procurement request from National Grid.

The process for tendering of reactive power service is summarised in Figure 3.

Figure 3 Reactive Power service tendering process

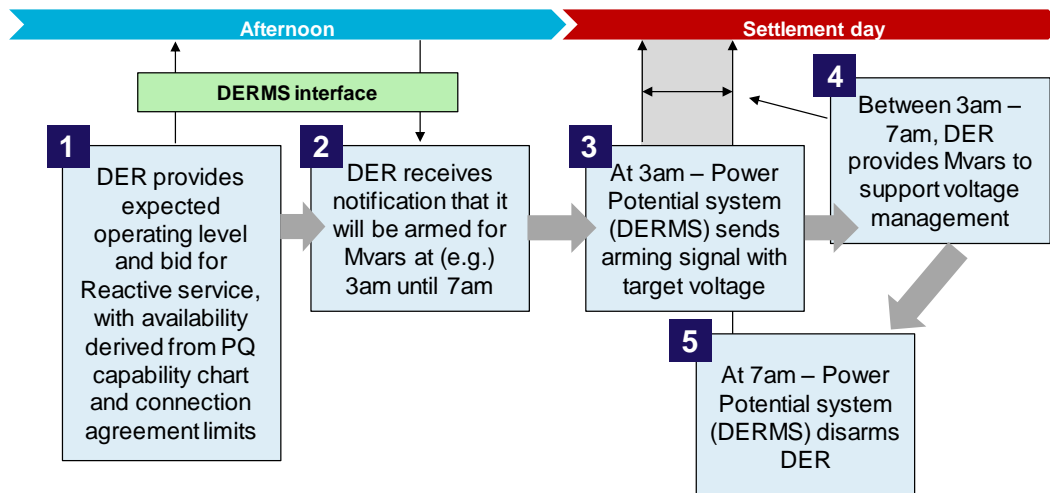

As with Wave 1, DER will indicate their availability for the Reactive service in three steps:

1. Through the use of the DER PQ capability chart and Connection Agreement limits. If the DER wishes to offer less than the full Reactive range of their asset they can do so via the web interface. The Q offering implied by the expected operating level must be non-zero for the bid to be valid.
2. By submitting a forecast of the MW expected operating level for each half-hour period in Service Windows (of the following day) into which the DER wishes to bid.
3. By indicating their willingness to offer Reactive Power services to the DERMS (e.g. via a 'tick box').

In Wave 2 there is an additional step, which is that for each Service Window, DER need to indicate an availability price (£/MVar/hr) and a utilisation price (£/MVarh) for Reactive power. If successful, DER will receive payment on a pay-as-bid basis. A zero price would be a valid input.

In choosing to offer the Reactive Service, a Participant, if successful, is committing to allow the DERMS to control the DER unit on instruction from National Grid within the operating range defined by the PQ capability chart (whether that is the original technical PQ capability or the updated chart to reflect a more limited range, if applicable). If successful in the tender, the availability payment received by the DER will be based on the Maximum Reactive Range. The Maximum Reactive Range is determined as the point where the Reactive Range is greatest on the PQ capability curve. This is independent of the operating point. The availability payment associated with each Service Window is given in Schedule 2 of the Power Potential DER Framework Agreement.

However, the actual Reactive Service availability will be a function of the outturn MW Operating level (see Figure 4). The Expected MW Operating level submitted by DER will be used to calculate their nominal reactive output and hence the reactive range expected to be available for reactive power dispatch. This expected reactive range will be used to build the availability stack and hence by National Grid to assess availability and effective price. The expected MW operating level, provided by the DER should represent an honest and accurate forecast, but the intention is not to apply any Performance Factor adjustment tied to MW

inaccuracies occurring during the trial (although Performance Factor adjustments linked to absolute availability can be incurred). The Active Power operating level between forecast and outturn will be reviewed as part of the trial and learning using to inform the development of future reactive power services.

Figure 4 Illustrative PQ capability chart

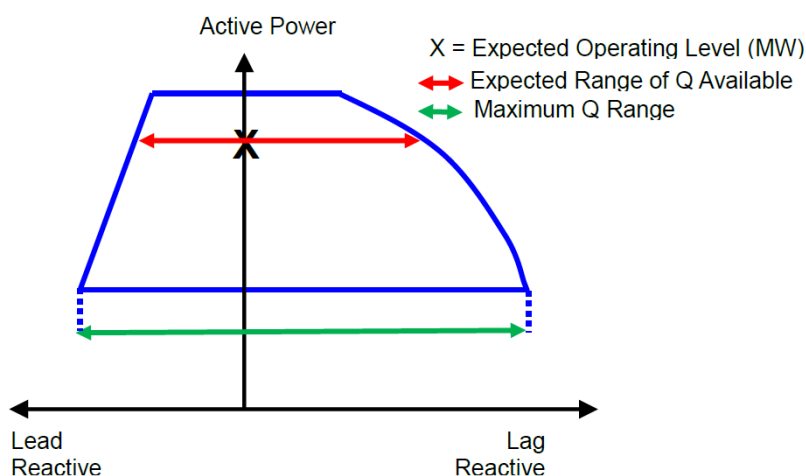

If a DER becomes unavailable within one or more Settlement Periods, the DERMS will detect this through the ‘heartbeat’ monitoring. There is no need, therefore, for the DER to notify UK Power Networks that it is unavailable. It is expected, however, that the DER will endeavour to restore availability as quickly as possible.

The market will be run for a minimum of 1800 hours, with the intention of running more if the trial budget allows. Indicative dates can be found in APPENDIX 1 – Market Trial Calendar.

3.3.2.2 Acceptance criteria⁵

At a high level, Power Potential is designed to mimic the situation in which National Grid procures the Power Potential services directly from Providers, but does so via the DERMS. The DERMS collects availability and utilisation bids by each Provider, carries out distribution network analysis, and presents an adjusted stack to National Grid (where the “adjustment” is described in more detail below).

Each DER will have been assigned to a particular GSP stack, representing the GSP to which they are most effective. National Grid will meet its requirement from some combination of volumes from each of these stacks (i.e. some stacks may have higher volumes accepted than others). Whilst DER will be initially assigned at the commissioning stage, they could be reassigned for a number of reasons during the trial, including:

1. Network changes, load flow changes, or improved calculations reveal that a DER is more effective at a different GSP from the one they were initially assigned
2. One or more GSP has insufficient participation to ensure a functioning market, so two or more GSP stacks are combined and assessed collectively. Note that in this case, no change would be made to the total volume that National Grid intends to procure.

⁵ Note that whilst the Power Potential team wishes to be fair and transparent about the acceptance criteria, it should be recognised that this is a trial and, as such, any of the decision-making criteria are subject to change.

National Grid determines what proportion of each stack to accept. In making this determination, National Grid will assess the cost of DER bids against the cost of installing or upgrading network assets to manage voltage constraints. In other words, a bid may be accepted if it is higher than the cost of dispatching flexible assets on the transmission network, but not if it would have been more cost-effective to resolve the constraint through network reinforcement. This is on the basis that the cost benefit analysis for Power Potential is to be assessed against the transmission asset counterfactual. A bid may also be rejected if, although cheaper than dispatching flexible assets available on the transmission network, it would have been more cost effective to resolve a constraint through network reinforcement.

Once National Grid has made its determination, the DERMS then indicates to the corresponding Providers that they have been successful at their tendered price.

From a Provider's perspective, assuming they can deliver what they commit to, they will receive payment in line with their bid price and the maximum reactive range implied by their PQ capability chart. For example, if a Provider has a maximum 1MVar capability, offers the Reactive Service for a 1-hour service window at a price of £5/MVar/hr with a utilisation bid of £10/MVarh, and is accepted on that basis they will receive £5 for that hour plus any utilisation paid at the bid price. However, Providers should be aware that the acceptance of a Provider's bid will depend on other factors.

Assessment factor 1: Expected Reactive Power range

The first factor is the expected range of reactive power available, as implied by the DER active power expected operating level. If the DER active power forecast implies a relatively low reactive power range the DERMS will use that reduced volume when building the availability stack for presentation to National Grid. The effective price of that volume would therefore be higher than if more reactive power was expected to be available. For example, using the same 1MVar Provider described above, if its expected reactive power range is 0.5MVar this would cost National Grid £10/MVar (£5 for 0.5 MVar), before accounting for the effectiveness of the DER with respect to the GSP.

Assessment factor 2: Effectiveness with respect to GSP

The second factor that will be taken into account is the "sensitivity" of a Provider to a GSP. The sensitivity value is defined as follows:

Sensitivity value is an indicator of the effectiveness of a DER reactive power injection in a particular GSP. Allocation of a DER to a particular GSP is done according to where this value is shown to be maximum (GSP reactive power variation Q_{GSP} divided by DER reactive power variation of Q_{DER}).

This is the key adjustment made by the DERMS. A GSP (or any point on the network) will be more sensitive to the injection or absorption of reactive power at some network locations than others. Some DER sites therefore can help to resolve network issues more effectively than others. Therefore, two Providers with identical bids could be seen differently by the DERMS, and hence by UK Power Networks. It may be that a Provider with a low bid but low sensitivity value is rejected in favour of a Provider with a higher bid but high sensitivity value. See table 4 below for an example. DER1 would be higher in the stack than DER2 as a result of its higher effectiveness despite its bid prices being higher than DER2.

Table 3 - Example of sensitivity factor impacting the DER stack

	DER1	DER2
Volume	5MVar	5MVar
Availability price	£1.50/MVar/hr	£1/MVar/hr
Utilisation price	£10/MVarh	£5/MVarh
Sensitivity value	80%	40%
Volume expected at GSP	4MVar	2MVar
Effective price in stack (Availability)	£1.88/MVar/hr	£2.50/MVar/hr
Effective price in stack (Utilisation)	£12.50/MVarh	£12.50/MVarh ⁶

Providers should therefore be aware that their sensitivity relative to other Providers could be a key determinant of the frequency with which their bids are accepted. A Provider with low sensitivity might need to lower their bid in order to increase that frequency.

Both the availability and utilisation price will be factored into the adjusted stack presented to National Grid, taking into account a forecasted utilisation of each DER calculated by the DERMS. This forecast utilisation is based on average historic utilisation values and DERMS will update its algorithm during the project lifetime to improve its accuracy of the likely utilisation calculation.

3.3.2.3 *Measuring, settlement and payment*

Response will be measured at the DER Connection Point of the Provider's site. The Power Potential project may make separate measurement of the service at different points on the network (e.g. GSP) but this will not be used for settlement purposes. This is a key learning outcome for the project and, as such, the project will bear this risk. Providers should be aware that this would be reviewed should a Power Potential service be rolled out as business as usual.

DER Reactive Service Providers will receive:

- ▶ Availability Payments for Reactive Power Availability accepted in the Power Potential Tender and
- ▶ Utilisation Payments for Reactive Power Response

Availability Prices (£/MVar/hr) and Utilisation Prices (£/MVarh) will be the prices submitted by DER Providers as bids for Service Windows at the day-ahead stage, and will be paid on a pay-as-bid basis.

The total Availability Payments received will be adjusted for DER performance. This means that at the end of each month, the aggregate number of Settlements Periods in which the DER was accepted and deemed to have been available (as measured under the logic

⁶ NB: prices used in this example are arbitrary and not intended to be illustrative of anticipated bid prices during the trial

specified for Wave 1) is compared to the total number of Settlement Periods that the DER service was accepted for, to calculate a Relevant Proportion of availability achieved.

A detailed description of the basis for DER payments for each service is given in Schedule 2 of the Power Potential Framework Agreement.

At the start of the service window for which DER was contracted, the DERMS will put the DER into voltage control / voltage droop control mode ('arm') and adjust their voltage set point to keep the MVar output as close as possible to the output prior to the change in operating mode. Initially, the voltage set-point will match the measure voltage at the DER Connection Point at the time of arming. This has the effect of maintaining the MVar produced by the DER as close to their default operating level as possible.

3.3.3 Wave 3

From the DER perspective, Wave 3 will operate in a similar manner to Wave 2. There are key features that should be noted:

- ▶ Wave 3 will only commence if National Grid determines that the Service is competitive with options already available to it on the transmission system. This decision will be made available to Providers and the wider market
- ▶ Power Potential services, if accepted, will be used to help secure the system
- ▶ Wave 3 bids will be met from National Grid's business as usual budget rather than the Power Potential trial budget
- ▶ Availability and Utilisation bids will be assessed in line with the cost of alternative actions
- ▶ National Grid will only accept the DERMS volumes where the price is as cost effective as alternatives available to it, meaning that some (or all) DER may not be accepted if they cannot reduce their bids to a competitive level.

3.4 Active Power Service

3.4.1 Mandatory Technical Trials

DER will need to complete a Mandatory Technical Trial before being able to participate in the Active Power Service. This will be scheduled with the DER who is expected to be available for one day. During the Mandatory Technical Trial DER will receive an administered Utilisation Price set to £150/MWh

There will be no Optional Technical Trial for the Active Power Service in Wave 1.

3.4.2 Active Power – Competitive Bidding

3.4.2.1 Participation process

DER must have completed the Mandatory Technical Trial in order to participate in the Competitive Bidding wave.

DER will be in competition with traditional options available to National Grid and so only be dispatched if economic to do so. The process for tendering of the Active Power Service is summarised in Figure 5.

- ▶ Power Potential services, if accepted, will be used to help secure the system
- ▶ Utilisation bids will be assessed in line with the cost of alternative actions
- ▶ National Grid will only accept the DERMS volumes where the price is as cost effective as alternatives available to it, meaning that some (or all) DER may not be accepted if they cannot reduce their bids to a competitive level.

3.4.2.2 Measurement, settlement and payment

There is no Availability Payment for the Active Power Service.

Active power utilisation is measured in terms of the deviation from a baseline level of active power output. The calculation of this baseline is detailed in Schedule 2 of the Framework Agreement.

Where Power Potential Active Power Trials have been initiated, DER Providers will receive Utilisation Prices for Active Power Response volumes accepted based on the prices submitted into the Power Potential Tender, as per the Framework Agreement.

The DERMS will instruct DER for utilisation based on its own measurement of real-time availability, and will be entitled to use the full range of flexibility technically afforded to it (as per the Framework Agreement). This may exceed the availability implied by the DER expected operating level submitted at the Day Ahead Power Potential Tender.

One additional constraint applies: the baseline must be within the maximum and minimum operating level of the plant (i.e. if the application of the scaling factor implies a baseline outside of the DER capability, the capability limit becomes the baseline).

Payments will be made by UK Power Networks to the DER Provider within [24] Business Days following the Relevant Month using the bank details given in the Provider's DER Framework Agreement.

Figure 5 Active Power service tendering process

Active power service tendering process

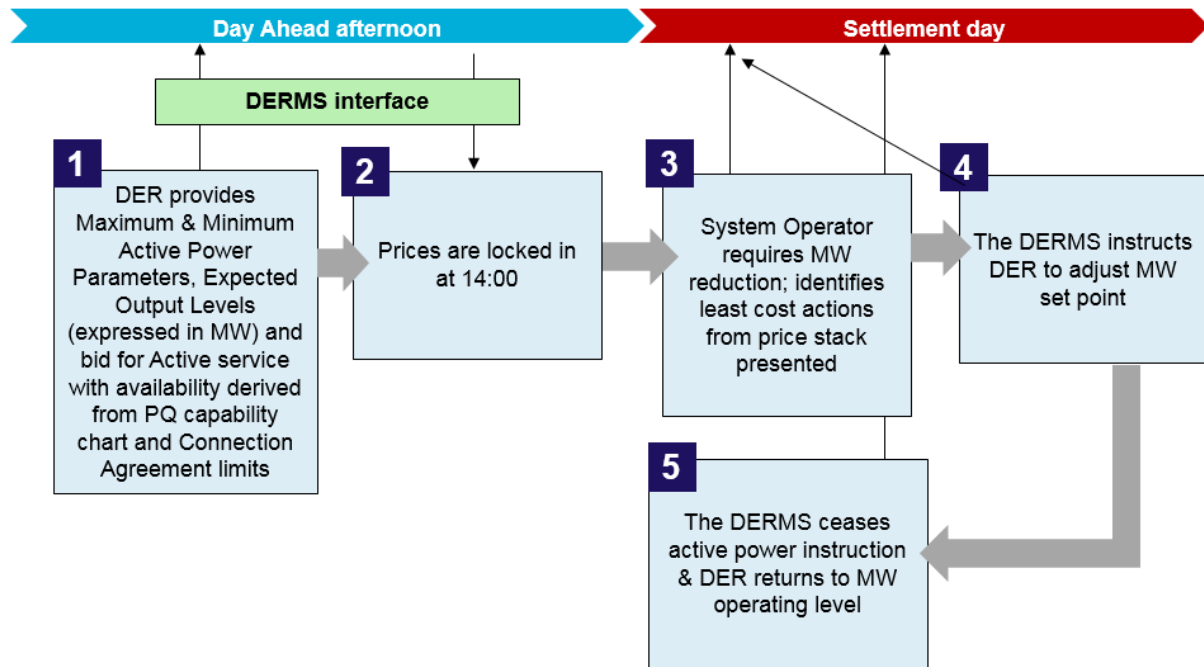

4 Market reporting

The Power Potential Project may use all technical and market data for the purposes of assessing the progress of the trial. In addition, the intention is to provide some level of market reporting on the outcomes of the tendering process. This should help to inform DER bidding activities. The level of detail is yet to be determined, and will need to consider:

- ▶ The need to anonymise commercially sensitive data
- ▶ The desire to be transparent about the procurement of system services
- ▶ The need to avoid facilitating anti-competitive bidding practices

The form of market reporting will be discussed with market participants before reporting commences. However, DER should be aware that the project team is minded towards full disclosure of bids and acceptances, along with the effectiveness estimates used in the assessment process. This reflects the direction of travel for existing System Operator services.

5 APPENDIX 1 – Market Trial Calendar

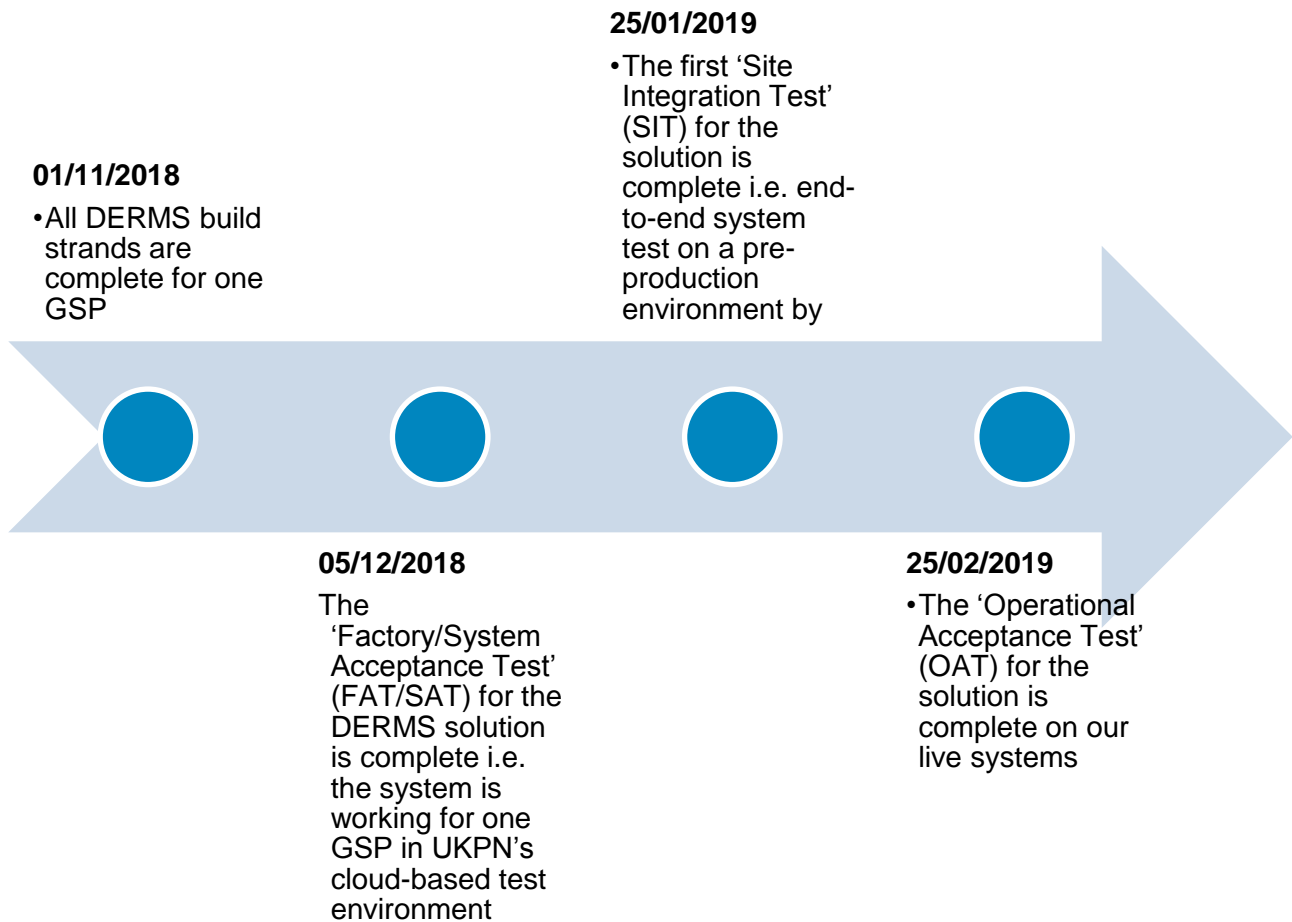

Date	Reactive Power Service			Active Power Service		
	Mandatory trial	Wave 1	Wave 2	Wave 3	Mandatory trial	Competitive bidding
2019	specific times to be agreed with DER	24/7 hours of opportunity across 2520 hours	commit to run market for a minimum of 1800 hours	pending decision to run wave 3	specific times to be agreed with DER	
11/Mar						
18/Mar						
25/Mar						
01/Apr						
08/Apr						
15/Apr						
22/Apr						
29/Apr						
06/May						
13/May						
20/May						
27/May						
03/Jun						
10/Jun						
17/Jun						
24/Jun						
01/Jul						
08/Jul						
15/Jul						
22/Jul						
29/Jul						
05/Aug						
12/Aug						
19/Aug						
26/Aug						
02/Sep						
09/Sep						
16/Sep						
23/Sep						
30/Sep						
07/Oct						
14/Oct						
21/Oct						
28/Oct						
04/Nov						
11/Nov						
18/Nov						
25/Nov						
02/Dec						
09/Dec						
16/Dec						
23/Dec						
30/Dec						

Key	
	No trial occurring
	Reactive Power Service
	Active Power Service

6 APPENDIX 2 – DUoS charges related to Power Potential

All users of the distribution network are subject to Distribution Use of System Charges (**DUoS reference below**). These charges are governed by DCUSA (**DCUSA reference below**). Charges identified as related to providing service through Power Potential include reactive power charges, excess capacity charges and normal charges for import / export from the network and associated distribution losses.

We confirm that reactive power and excess capacity charges will not be applied to DER when they are providing service under Power Potential. Within the existing methodology for Distribution Use of System Charges, if the DNO requests a change in how a generator operates, then charges will not apply. An instruction from DERMS to operate with a power factor less than 0.95 or to exceed a maximum import capacity would be an example of such an instruction.

No change to the existing charging methodology or contractual arrangements are required to implement this, so this has not been included as an additional clause in the DER Provider Agreement. Any excursions will be logged as Trial learning.

For the specific example of reactive power charges, these charges are not currently levied for EHV connections (customers charged under the EHV Distribution Charging Methodology), so Power Potential could not lead to a change. For HV and LV connections, there are reactive power charges for operating in a power factor range outside 0.95, but DCUSA Schedule 16, table 7 note 7 states these not apply when the DNO requests the change in power factor.

Loss adjustment factors in the DUoS charging methodologies are the assumed losses in MWh relative to a customer's energy consumption in MWh. Loss adjustment factors for each type of HV and LV customer are derived annually for the whole network based on actual historic MW data and notional power factor, so losses for any specific customer would not be altered by participation in the Trial. Loss adjustment factors for EHV customers are modelled annually based on half-hourly historic site-specific power flows, including the normal power factor of operation rather than any temporary change to that power factor, so the site-specific loss adjustment factors would also not be altered by participation in the Trial, either in the year of Trial or the following year. However if a DER alters its total MWh consumption or export during the Trial period, whether due to the Trial or not, this would lead to change in the MWh consumption and export charges, and via the loss adjustment factor a change in the cost of losses for the site.

Distribution Use of System Charges (reference)

- ▶ <https://www.ukpowernetworks.co.uk/internet/en/about-us/duos/operatingin.html>

DCUSA reference

- ▶ <https://www.dcusa.co.uk/SitePages/Documents/DCUSA-Document.aspx>
- ▶ <https://www.dcusa.co.uk/DCUSA%20Document%20Public%20Version/DCUSA%20v10.2%20Public.pdf>