

National Grid UK Electricity Transmission plc

Uncontrolled when printed

NATIONAL SAFETY INSTRUCTION and Guidance

NSI 12 LOW VOLTAGE EQUIPMENT

Copyright National Grid plc 2016 ©, all rights reserved. No part of this publication may be reproduced, stored in a retrieval system, or transmitted in any form or by any means electronic, mechanical, photocopying, recording or otherwise, without the written permission of National Grid obtained from the issuing location.

The contents of National Grid documents are based on the needs of National Grid and the conditions under which it operates. It shall not therefore be assumed that the contents stated therein necessarily meet the particular circumstances and requirements of other organisations. The principles set out in this document are for information only and therefore National Grid is not liable to any third party for any loss or damage resulting from reliance on the contents. It is the responsibility of such external organisations to check that the document is the latest version and is appropriate for their purposes.

DOCUMENT HISTORY

Issue	Date	Summary of Changes / Reason	Author(s)	Approved By (Title)
1	Dec 2011	New Guidance Document to follow 3 rd edition Electricity Safety Rules layout	NSI Working Group	MDE Manager Les Adams 
2	April 2016	Document reviewed and updated in line with comments, significant document changes highlighted.	NSI 12 Review Group	ETAM Operations North Manager Matt Staley

KEY CHANGES

Section	Amendments
2	Definitions updated.
4.1	Requirement for a written risk assessment specified.
5.1 Guidance	Management of fuses and links where LV Point(s) of Isolation cannot, where reasonably practicable be locked.
5.4	Updated to reflect the Safety Rules (fourth edition).
6.2 Guidance & Appendix A	Screening of Live LV Equipment & testing of Live LV Equipment may be completed by a Senior Authorised Person without the issue of a Safety Document subject to conditions.
Various	50V AC Raised to 100V AC in accordance with updated calculations from TR(E)476.
Various	Reference to TP 106 and TP141 removed.

LOW VOLTAGE EQUIPMENT

CONTENTS

	Page
1 Purpose and Scope	1
2 Definitions	1
3 Dangers	2
4 General Requirements for Work	3
5 Work <i>On or Near</i> to LV Equipment which has been made Dead	4
6 Work <i>On or Near</i> to Live LV Equipment	6
7 Work on Current Transformer Secondary Circuits	10
Appendix A – Screening Process	13
Appendix B – Process for working on Current Transformer Circuits with the Primary Circuit Live	15
Appendix C - Record of All Disturbances, Disconnections and Reconnections Associated with Testing	18
Appendix D - Authorisation Matrix for Personnel	19

1 Purpose and Scope

To provide guidance on National Safety Instruction 12, when applying principles established by the Safety Rules to achieve **Safety from the System** for **Personnel** working *On or Near to Low Voltage Equipment*.

In order to be appointed to NSI 12 it is required that staff are nominated as electrically competent by their line manager.

The calculations and safe systems of work in this NSI are based on the principles of Technical Report TR(E)468, *Tolerable Body Voltage Calculations (Direct Current)* and Technical Report TR(E)476, *Tolerable Body Voltage Calculations (Low Voltage AC systems)*.

The layout of this guidance note reflects that of legislative codes of practice, where the rule (or mandatory obligation) is identified by a green panel on the left-hand side. The guidance follows after the rule and is identified by a blue panel.

Within National Grid the guidance notes hold equivalent status of an Approved Code of Practice (ACOP) in law. If not followed, you will be required to demonstrate that your safe system of work is of an equal or higher standard.

2 Definitions

Terms printed in bold type are as defined in the Safety Rules.

Title	Definition
<i>Conductor</i>	A metallic or similar item that conducts electrical energy
<i>On or Near</i>	Exposed Live LV Equipment that can be touched either directly or indirectly during the course of work.
<i>Dangerous Energy Level</i>	An energy level contained within batteries that are part of the System or of Low Voltage systems in which currents are not inherently limited.
<i>Dangerous Potential</i>	A potential over 100V AC RMS or 55V DC
Impressed Conditions	Conditions which could cause dangerous induced voltages or currents, differences in earth potential or voltage differences in earth potential or voltages across any break in the conductive path.
Safe Custody	A Key Safe or secure place that has been locked and the key(s) locked in a Key Safe .

3 Dangers

The **System Danger(s)** to **Personnel** working *On or Near* exposed **Live LV Equipment** are electrocution, burns and effects on eyes arising from:

- **Personnel** mistaking **Equipment** on which it is safe to work
- **Equipment** being worked on accidentally or inadvertently being made **Live**
- Inadequate precautions being taken under **Live** conditions
- *Dangerous Potential* on open-circuited current transformer secondary windings and associated wiring arising from open circuits or disconnection from earth
- Short Circuit of **Live LV** system
- Induced voltages or currents arising from fault or load currents in other **HV and LV** circuits.

NSI 12
4.1 to 4.3

4 General Requirements for Work

- 4.1 The preferred method shall be to work *On or Near* to **LV Equipment**, which is **Dead**. This procedure does not allow **Personnel** to work **Live** when it is reasonably practicable to work **Dead**.

A **Senior Authorised Person** shall assess the means of achieving **Safety from the System** and determine whether work is to take place under **Dead** conditions or can be justified under **Live** conditions. **Before any work *On or Near* to LV Equipment is carried out a written risk assessment shall be completed, the assessment shall determine whether a Safety Document is to be issued as a control.**

- 4.2 When work on **LV Equipment** requires portable instruments to be used for measurements, the instruments or associated leads shall incorporate protective devices to prevent **Danger**.
- 4.3 Safety shall be maintained across all internal and external control boundaries.

Guidance
NSI 12
4.1 to 4.3

4 General Requirements for Work

- 4.1 Conductors are not considered **Live** for inadvertent contact where they are suitably covered with insulating material / shrouding which prevents **Danger**.

Where there is a possibility of the presence of flammable gas, which might be inadvertently ignited by electric sparks, the **Senior Authorised Person** shall consider consulting an appropriately qualified specialist, to provide advice to ensure a safe system of work is established.

Where the possibility of LV cables being subject to impressed voltage conditions exists, the Senior Authorised Person shall refer to NSI 5 - Cable Systems.

- 4.2 Instruments and associated tests leads shall be fuse (or equivalent) protected and provided with suitably insulated probes and test leads.

- 4.3 **LV Equipment** with an associated **HV** control boundary.

When working on the boundary, the **LV Control Person (Safety)** shall contact the **HV Control Person (Safety)** and arrange for a Record of Inter System Safety Precaution (RISSP) in accordance with Management Procedure UK BP/SE 301 – “Managing Safety Interfaces”.

LV Equipment with an associated third party **LV** control boundary.

Connections to third party **LV** systems shall be managed in accordance with NSI 33 - The Addition/Removal of Equipment To/From the System.

NSI 12
5.1 to 5.7

5 Work On or Near LV Equipment which has been made Dead

- 5.1 The appropriate **Control Person** shall ensure **Equipment** to be worked on is **Isolated** and **Point(s) of Isolation** established. Fuses, links and **Safety Key(s)** used to secure the **Point(s) of Isolation** shall be retained in *Safe Custody*.
- 5.2 The **Senior Authorised Person** shall where reasonably practicable ensure inadvertent contact is prevented from adjacent **Live LV Equipment** by establishing **Point(s) of Isolation**. Where this is not reasonably practicable **Danger** shall be prevented by the application of screening.
- 5.3 The **Senior Authorised Person** shall prove the circuit or **Equipment** is not **Live**.
- 5.4 A **Senior Authorised Person** shall assess the work and as part of the risk assessment process decide to apply the following controls as appropriate:
- a) **Permit for Work**
 - b) **RAMS and Personal Supervision** by the **Senior Authorised Person**
 - c) **RAMS only**
- 5.5 Before commencing work the **Competent Person** shall prove that the **LV Equipment** to be worked on is **Dead**.
- 5.6 Work shall be carried out by or under the **Supervision** of a **Competent Person**.
- 5.7 During the work, the **Competent Person** shall inspect the screening where applied and ensure its integrity is maintained.

Guidance
NSI 12
5.1 to 5.7

5 Work On or Near to Dead LV Equipment

5.1 Fuses, links and **Safety Key(s)** shall be kept in Safe Custody, so they cannot be lost or interfered with e.g. **Locked**.

Point(s) of Isolation shall be recorded on an apricot coloured Tee Card. Where there are large numbers of **Point(s) of Isolation** they can be recorded, together with other disconnections, on a "Record of All Disturbances, Disconnections and Reconnections Associated with Testing (ROADRAT)" form F1 in Appendix C. The Tee Card shall reference the ROADRAT form and this shall be available near to the Substation Status Board.

If **LV Point(s) of Isolation** cannot, where reasonably practicable be locked, then all associated fuses and links shall be retained in *Safe Custody*. All adjacent 'spare' fuses and links shall also be managed to prevent compromising the isolation.

5.2 When working on **Dead LV Equipment** it may be necessary to exclude **Danger On or Near** the work area. The **Senior Authorised Person** shall:

(a) Establish **Point(s) of Isolation**

or

(b) Apply screening, refer to Appendix A

If (a) or (b) cannot be achieved then refer to **Section 6 "Working On or Near to Live LV Equipment"**.

5.3 The **Senior Authorised Person** shall check that the **LV Equipment** to be worked on is **Dead**, by means of a voltage testing device. The device shall be tested for correct function immediately before and after use.

5.4(c) When a **Senior Authorised Person** sets themselves to work the risk assessment process shall be to the same standard of setting a third party to work.

5.5 Before commencing work the **Competent Person** shall check that the **LV Equipment** to be worked on is **Dead** by means of a voltage testing device. The device shall be tested for correct function immediately before and after use.

5.6 A **Senior Authorised Person** shall assess the work and specify the level of **Supervision** required by the **Competent Person**.

5.7 Any changes in the condition of the screening e.g. disturbance or condensation forming, will result in the **Working Party** being withdrawn and the **Senior Authorised Person** informed.

NSI 12
6.1 to 6.6

6 Work On or Near to Live LV Equipment

- 6.1 Work shall not be permitted *On or Near* any **Live LV conductor** where **Danger** may arise unless:
- a) It is unreasonable in all the circumstances for it to be **Dead**;
and
 - b) It is reasonable in all the circumstances to be at work *On or Near* it while it is **Live**;
and
 - c) Suitable precautions (including where necessary the provision of suitable protective equipment) are taken to prevent injury
- 6.2 The **Senior Authorised Person** shall assess the work required *On or Near* to **Live LV Equipment** and ensure a safe system of work is developed. This shall include the decision to issue a **Certificate for Live LV Work** as a control.
- 6.3 The **Senior Authorised Person** shall consider the use of an additional **Competent Person** if the presence of such a person could contribute significantly to ensuring that injury is prevented or effects mitigated.
- 6.4 Where necessary, to avoid **Danger**, the following controls shall be considered and implemented as appropriate: insulated screening, insulated tools, insulated mats, insulated gloves, adequate lighting and adequate workspace / access.
- The **Competent Person** shall remove any metallic objects such as wristwatches, rings, wristlets, cufflinks, pendants, items of clothing with exposed metallic zips, etc.
- 6.5 The work shall only be carried out by a **Competent Person** who has the appropriate knowledge, training and experience.
- 6.6 During the work, the **Competent Person** shall visually inspect the screening where applied and ensure its integrity is maintained.

Guidance
NSI 12
6.1 to 6.2

6 Work On or Near to Live LV Equipment

6.1 Work which includes **Live** testing / commissioning is justifiable. It does not follow that there will be justification for repair work to be carried out **Live**.

6.2 A **Certificate for Live LV Work** may be issued for any work *On or Near* to **Live LV Equipment** if it adds value to the safe system of work.

Screening of **Live LV Equipment**, may be applied and removed by a **Senior Authorised Person** subject to paragraph 4.1 without the issue of a Safety Document, providing insulated working is used.

Testing of **Live LV Equipment** may be completed by a **Senior Authorised Person** subject to paragraph 4.1 and 4.2 without the issue of a **Safety Document**, providing insulated working is used.

Battery Terminals Connections and Battery Distribution Boards

A **Certificate for Live LV Work** shall be issued when working on battery terminals, connections and distribution boards other than:

- Routine / testing work identified under category 2 work as defined in Management Procedure "Work and Work Execution"
- Screening applied / removed by an **Senior Authorised Person**

Protection against dangerous energy levels can be afforded by circuits being sub-fused (mcb). The fuse (mcb) is designed to protect the cable from short circuit faults and hence will limit the energy provided by the battery.

A Safe System of Work

Voltages Exceeding 100V AC RMS or 175V DC

Working **Live On or Near Conductor(s)** subject to these voltages could result in death and will only be carried out after a **Senior Authorised Person** has issued a **Certificate for Live LV Work**. Screening or non intrusive testing completed by a **Senior Authorised Person** is excluded from this requirement.

Voltages Exceeding 55V DC and less than 175V DC

Note: Excludes work on battery terminals, connections and distribution boards due to dangerous energy levels.

Calculations in Technical Report TR(E)468, *Tolerable Body Voltage Calculations (Direct Current)* and complexity of National Grid Secondary Systems can justify **Live** working. The **Senior Authorised Person** may determine a **Certificate for Live LV Work** for minor work at these voltages is not required as part of the safe system of work. The following guidance can be used:

a) It is unreasonable in all circumstances for it to be **Dead**

It is not reasonable to isolate all circuits e.g. circuit breaker fail, interlocking schemes for minor work over and above

Guidance
NSI 12
6.2 Cont. to 6.3

local isolation e.g. fuses, links, MCB's at the **Equipment**.

- b) Is it reasonable in all circumstances to be at work *On or Near* it while it is **Live**

Applying suitable precautions identified in Section (c) below and calculations in Technical Report TR(E)468 manage the risk.

- c) Suitable precautions (including where necessary the provision of suitable protective equipment) are taken to prevent injury.

Shrouding / screening shall be applied where **Danger** may arise from source 110 V DC systems e.g. J101, J102 next to each other on a terminal block.

The **Working Party** shall be advised that **Live** voltages at this level may be present and the controls specified in Section 6.4 shall be implemented.

Examples of Minor Works:

- **Application / removal of screening material by an Senior Authorised Person**
- Minor repair work during testing and commissioning of short duration e.g. crossed wires
- Voltage / current measurements during commissioning
- Cleaning auxiliary contacts under National Grid Maintenance Documents
- Isolations created to allow major work to proceed e.g. wires isolated in relay panels of other circuits to allow NICAP protection installation work to proceed

Where **Equipment** at these voltages is worked on and is near other **Equipment** of higher voltages or energy levels that could give rise to **Danger** Section 5 or 6 of this procedure shall be followed.

Voltages not Exceeding 100V AC RMS or 55V DC

Note: Excludes battery terminals, connections and distribution boards due to dangerous energy levels.

Calculations in Technical Report TR(E)476, *Tolerable Body Voltage Calculations (Low Voltage AC systems)* and complexity of National Grid Secondary Systems can justify **Live** working.

Nominal 50 V DC sub fused (mcb) secondary wiring does not have sufficient energy level to cause harm and the issue of a **Certificate for Live LV Work** is not required.

Where **Equipment** at these voltages is worked on and is near other **Equipment** of a higher voltage or energy level that could give rise to **Danger** Section 5 or 6 of this procedure shall be followed.

- 6.3 Any accompanying **Competent Person** shall be trained to recognise **Danger** and to render assistance in the event of an emergency and raise an alarm, e.g. authorised to NSI 12 and emergency first aid trained.

Guidance
NSI 12
6.4 to 6.5

6.4 When working on Live LV Equipment it may be necessary to exclude Danger from adjacent Live LV Equipment or any potential difference e.g. between Conductors or Conductors and metal work bonded to earth etc. in or near the work area by the application of screening.

Screening shall be applied as per Appendix A.

6.5 Certain **Live LV** work should only be carried out by **Personnel** who are trained and experienced to work in such **Live** environments routinely. Work could be low risk activities such as working in marshalling kiosks with **Live** 110 V DC wiring to high risk activities such as **Live** 415 V cable jointing. Knowledge, training and experience will be appropriate for the task in hand.

This will include the provision of adequate information to the **Competent Person** carrying out the work regarding the **Live** conductors involved, associated electrical system and foreseeable risk. The use of suitable tools, including insulated tools, equipment and protective clothing, use of suitable insulated barriers or screens. Insulated tools and equipment shall be confirmed as suitably rated and appropriately tested.

The responsibilities required of the accompanying **Competent Person** shall be clearly communicated to them before work starts along with all emergency arrangements established.

NSI 12
7.1 to 7.3

7 Work on Current Transformer Secondary Circuits

7.1 Work on Current Transformer (CT) secondary wiring shall where reasonably practicable be undertaken with the primary circuit **Isolated**.

Where the work requires disconnection of the secondary wiring, **LV Point(s) of Isolation** shall be established on the CT circuit.

The **Senior Authorised Person** shall ensure all secondary outputs of the CT's (all phases or as appropriate) are shorted, if there is a **Danger** of circulating currents flowing in the **HV** primary circuit. Short circuits shall be applied between the point of work and the CT windings.

7.2 Where it is not practicable to short CT secondary outputs which involve a disconnection the **Senior Authorised Person** shall ensure that the primary circuit is **Isolated**, **Points of Isolation** established and a **Safety Document** issued.

7.3 It may be justifiable to work on the CT circuit with the primary circuit **Live**. In this instance a **Certificate for Live LV Work** shall be issued. Once **LV Point(s) of Isolation** have been established by disconnections a **Permit for Work** can be issued.

Guidance
NSI 12
7.1

7 Work on Current Transformer Secondary Circuits

- 7.1 Special precautions are required when working on Current Transformer (CT) Circuits. The driving flux of a CT is always present when primary current is flowing and therefore, if the secondary load is inadvertently disconnected, very high voltages will be developed across the secondary winding with the risk of injury to **Personnel** and damage to **Equipment**.

With the primary circuit out of service a hazard may still be present because of the potential for current to flow in the CT in the event of a primary **System** fault or if the primary circuit is **Earthed** for maintenance and circulating current is flowing.

LV CT secondary wiring disconnections created as **Point(s) of Isolation** shall be quoted on the **Safety Document**.

Requirements for CT Secondary Wiring Shorting Connections

Existing, dedicated, bolted CT shorting links, when available, shall be the first choice for shorting CT secondary wiring.

Where existing, dedicated, bolted CT shorting links, are unavailable stud terminals that have sufficient length to accept a ring crimp terminal(s), an anti-rotation washer and a full nut should be used. Other methods may be adopted provided they meet the fundamental principle outlined above.

Shorting connections shall be a minimum of 1.5mm² **insulated** stranded copper cable. They shall be labelled as per Fig. B1 Appendix B.

Note: Crocodile clips are not 'mechanically secure' and shall not be used.

The application of shorts to spring loaded and similar terminal blocks is not permitted as it cannot normally be carried out without disturbing the existing CT wiring. However, terminal blocks with facilities for screw-on links may be used provided the correct shorting links are used.

Another option may be the use of a test plug inserted into a test socket using shorting connections designed by the manufacture for the test plug / socket, e.g. MMLB01, MMLG (although the use of stud connections, if available, is the preferred option).

Current transformer shorts shall be recorded in "**Actions taken**" of the relevant **Safety Document** or Section 4 of a **Certificate for Live LV Work**.

Ensure **Danger** is excluded from **Charged** CT secondary wiring by ensuring that the CT wiring being worked on is always earthed at one point, which shall be on the source side of any disconnections made. Multiple earth points on a CT's secondary circuit can establish earth loop currents.

Guidance
NSI 12
7.2 to 7.3

- 7.2 When working directly on CT secondary terminals and it is not practicable to apply Section 7.1, then a **Safety Document** shall be issued. The primary circuit shall be arranged such that no primary current can flow in the CT primary. This shall be achieved by ensuring a physical break is formed by a disconnect, Circuit Breaker or a break in the **HV** conductor on one side of the CT and that a circulating current path is not formed by the application of **Earthing Device(s)**.
- 7.3 For work on CT circuits with the primary circuit **Live** the procedure in Appendix B shall be followed. Work which includes **Live** testing / commissioning is justifiable. It does not follow that there will be justification for repair work to be carried out **Live**.

Appendix A – Screening Process

- a) Screening may be required to avoid **Danger** from **Live LV Equipment** being touched either directly or indirectly.

Senior Authorised Person to apply / remove screening:

Screening of **Live LV Equipment** may be applied and removed by an **Senior Authorised Person** subject to paragraph 4.1 without the issue of a **Safety Document**, providing insulated working is used e.g. use of insulated gloves, tools etc.

Competent Person to apply / remove screening:

A **Competent Person** shall apply screening to **LV Equipment** under an appropriate **RAMS** and **Safety Document**, or under the **Personal Supervision** of a **Senior Authorised Person** when providing physical assistance.

- b) Screening material shall be secured to ensure that it remains an effective barrier for the duration of the work. The edges of the screening should be secured to ensure that no access is allowed to any **Live LV Equipment**.



Figure A1 – Example of Incorrect Screening Material and Screening

- c) The **Senior Authorised Person** or **Competent Person** shall remove any metallic objects such as wristwatch, rings, wristlets, cufflinks, pendants etc.

If a **Certificate for Live LV Work** is required, it shall record controls such as the use of insulated tools, mats and gloves whilst erecting screens to avoid **Danger**.

- d) The removal of screening shall be carried out to the same standard as the original application.

SUITABLE SCREENING MATERIAL

- a) Screening material shall be able to withstand a voltage up to and including 1000 volts and shall have sufficient mechanical strength to withstand an accidental blow from a tool without tearing or ceasing to be effective.



Figure A2 – Example of Rubber Screening Material and Clips

- b) The pictures below depict examples of correct application of screening.

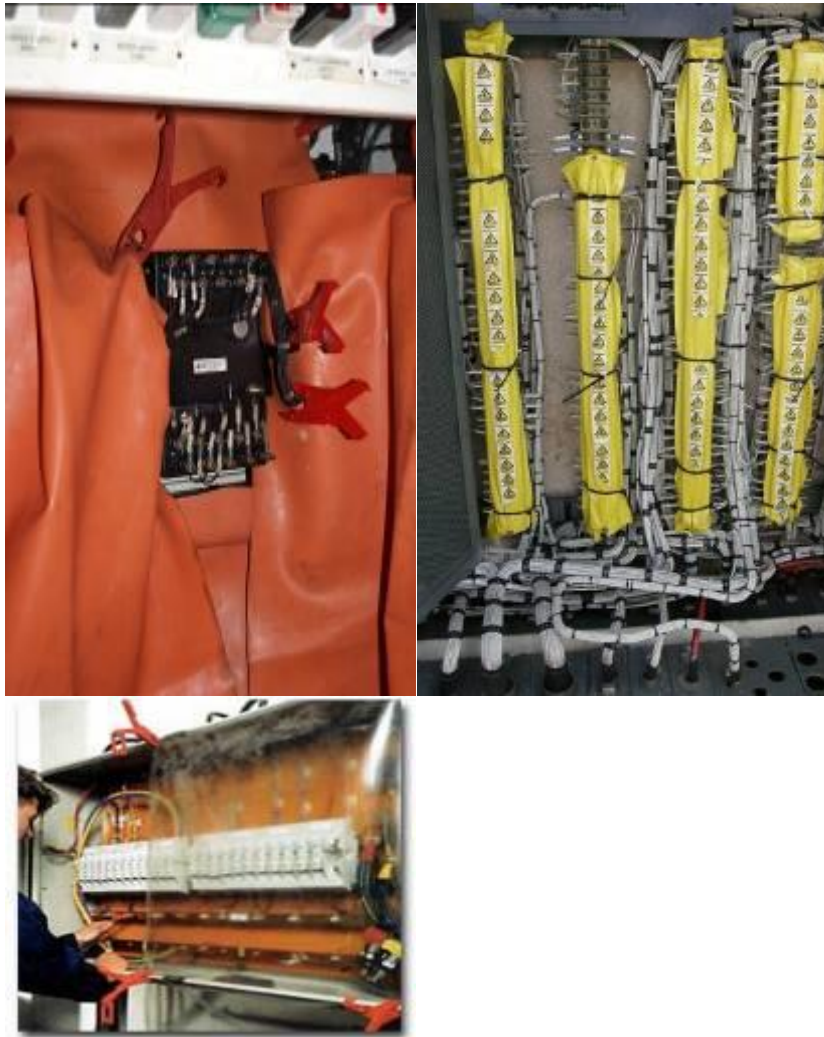

Figure A3 – Examples of Correct Application of Screening Material

Appendix B – Process for Working on Current Transformer Circuits with the Primary Circuit Live

PLAN THE WORK

- a) Site circuit and wiring drawings should be referred to so that the electrical and physical run of the CT wiring is known between all termination points and the sequence of all the series connected devices established.

Any discrepancies between the circuit diagram, the wiring diagram and the physical installation shall be resolved before proceeding. The location of the star point (if any), residual / neutral return and earthing point **may** be established **if it adds value**. A working sketch of the existing wiring may be made if it adds value. This may be hand drawn provided it is clear. An example is attached as Figure B2.

- b) **The Control Person (Operation)** shall be consulted with regards to the provision of protection outage booking and agreement to any loss of function(s): both protection and operational metering.
- c) Most CT 'stacks' have several cores to give different protection functions e.g. 1st Main, 2nd Main, Measurements, Busbar Discrimination and Busbar Check. The function to be worked on shall be correctly identified. Work should only be carried out on one protection function at a time.
- d) Prior to removal of CT shorting connections a suitable testing schedule shall be produced to confirm the continuity of the CT circuit is re-established.

PREPARATION

- a) Before any work commences CTs shall be short circuited as per Section 7.1 and / or CT wiring bypassed.

Where reasonably practicable a disconnection shall be made between the short applied to the CT and the point of work.

Care must be taken not to apply a second earth to the CT secondary system due to the risk of earth loop currents. Where necessary to ensure safety, the two earths must only be connected for a brief changeover period.

- b) The actual position of the work and its effect on existing **Equipment** shall be clearly understood. The position of the required temporary short(s) should then be marked on the working sketch. The working sketch should be checked independently by a suitably qualified person **e.g. Commissioning Engineer** who understands the nature of the work being carried out. The information on the working sketch shall be agreed, signed, names clearly written and dated by both parties.
- c) If it is necessary for some of the existing **Equipment** to continue in service e.g. circuit breaker fail, then shorts will have to be applied which bypass the point of work. Wherever possible these shall be positioned in or between, panels or racks that do not contain any of the new wiring work. Particular care shall be exercised if it is proposed to work on wiring associated with circulating current protection schemes to avoid unnecessary tripping. 'A Risk of Trip' should be agreed with **the Control Person (Operation)** for this work.
- d) The application of the temporary short(s) shall be earth side first (e.g. A80) using insulated tools. Where reasonably practicable the making of a disconnection in the CT wiring between the short(s) and the point of work shall be carried out under a **Certificate for Live LV Work**.

Warning: The application and removal of shorting connections one phase at a time will result in significant currents flowing in residually connected **Equipment** e.g. System Backup Protection. This should be assessed from the working sketch and the outputs of any such devices temporarily inhibited while shorts are being applied and removed.

Temporary labels shall be added to the shorting connection(s) as per Figure B1.

DANGER: TEMPORARY CT SHORTING CONNECTION DO NOT REMOVE WITHOUT INSTRUCTION	Ref.
Site SAP Name:	
CPO Name:	
Date & Time:	

Figure B1 – Temporary CT Short Label

- e) Where wiring is used to bypass a device and is landed in different parts of a panel (or even different panels) it shall be run neatly and some form of temporary cleating used to avoid it being accidentally pulled or tripped over.
- f) When the shorting connections have been applied, a clip on ammeter should be used to check the current flowing in the CT circuitry to ensure that the major portion of the current has transferred to the short(s). Values should be marked on the working sketch.

DOING THE WORK

- a) Work can proceed under a **Certificate for Live LV Work** or by cancelling the **Certificate for Live LV Work** and issuing a **Permit for Work** quoting the disconnection(s) in the CT wiring as **Point(s) of Isolation**.

REINSTATEMENT

- a) Once the work is complete and if a **Permit for Work** has been issued to carry out the work this shall be cancelled and a **Certificate for Live LV Work** issued allowing **the remaking** of the disconnection(s) and the removal of the short(s).
- b) Before the new **Equipment** is deemed ready for service, the **Senior Authorised Person** shall ensure that the continuity of the CT circuit is re-established using the test schedule developed during the planning stage. The disconnection(s) can now be re-made and inspected for integrity and tightness. All these actions should be checked independently by a suitably qualified person **e.g. Commissioning Engineer**.
- c) A clip on ammeter should be used to establish the current(s) flowing in the existing wiring and the short(s). An insulated tool should be used to carefully remove the first short from the **'Live'** (e.g. not earthed, A80 etc.) side on the first phase. The connection should be carefully lifted off whilst checking that no significant arcing is present. Use the clip on ammeter to confirm that the expected current is flowing in the new wiring.
- d) Repeat for the other phases and finally remove the earth end. Confirm that the new and existing **Equipment** is operating as expected. Remove all temporary precautionary measures. Confirm to **the Control Person (Operation)** that work is complete, record any exceptions and declare the circuit ready for service checking that no alarms are outstanding.

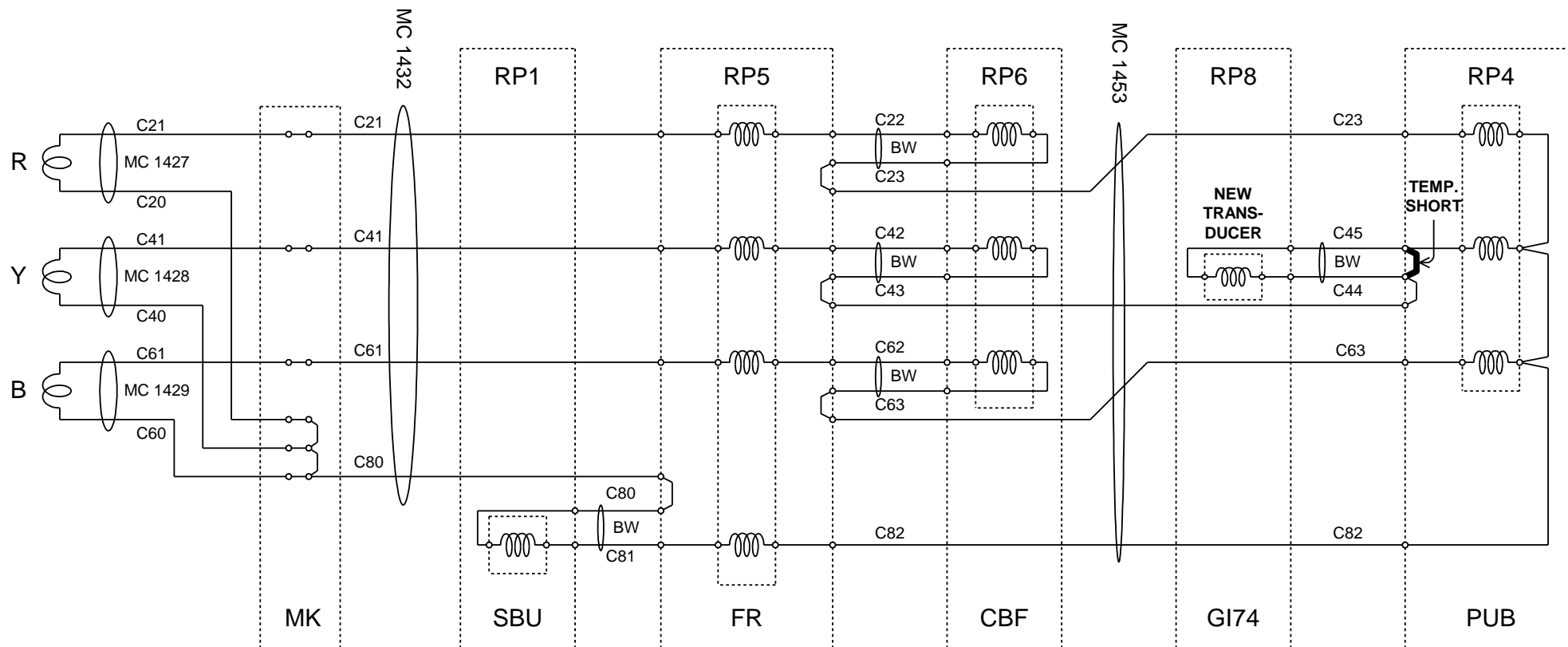

KEY:

MK = MASHALLING KIOSK

SBU = SYSTEM BACKUP

FR = FAULT RECORDER

CBF = CIRCUIT BREAKER FAIL

GI74 = SYSTEM METERING

PUB = PHASES UNBALANCED

RP = RELAY PANEL

BW = PANEL BUS WIRING

MC = MULTICORE No

NOTE: A WORKING DRAWING WOULD NORMALLY BE HAND DRAWN BUT SHOULD CONTAIN THIS LEVEL OF DETAIL

Figure B2 – Working Sketch of Current Transformer Shorting Connections

Appendix D - Authorisation Matrix for Personnel

Non Company Personnel as defined in NSI 30	Person	Competent Person	Authorised Person	Senior Authorised Person
N/A	N/A	Sections 1 2 3 4 5 6 Appendix A	N/A	All Sections

Non Company Personnel

Contractors by law have a duty to provide a safe system of work for their employees.

National Grid have a duty in law to employ competent contractors to undertake work *On or Near LV Equipment* and provide them with National Grid's safe system of work to enable them to develop their own safe systems of work.

National Grid Supply Chain Management processes ensure competent contractors are selected and therefore there is no requirement for authorisation under NSI 12.

Once a competent contractor is selected, National Grid has a duty to ensure the contractor understands **Danger(s)** associated with undertaking work within a **HV** compound, permit systems, demarcation and safe access and egress, including movement of objects and vehicles etc. This is accomplished by contractors employees being authorised to National Grid Safety Rules and to NSI 6 and 8, via Management Procedure - NSI 30 "Appointment of Persons".

Before a **Safety Document** is issued the NSI 12 **Senior Authorised Person** shall establish **Safety from the System**. The contractors risk assessment and method statement shall be reviewed by the **Senior Authorised Person** to ensure the **Danger(s)** identified in NSI 12 are suitably managed.

The National Grid **Senior Authorised Person** will issue a **Safety Document** to a contractor's **Competent Person** authorised to NSI 6 & 8.