Specification for safe working in the vicinity of National Grid high pressure gas pipelines and associated installations – requirements for third parties



Contents

Disclaimer	02
Mandatory and non-mandatory requirements	02
Introduction	03
1 Scope	05
2 Formal consent	05
3 HS&E considerations	07
4. Pipeline locating	08
5 Slabbing and other protective measures	09
6 Excavation	10
7 Construction traffic	15
8 Specific activities	16
9 Backfilling	20
10 Action in the case of damage to the pipeline	20
11 References	21
12 Glossary of terms	21
Appendix A – Site Document Control Form	22
Appendix B – Pipeline Location Flags	24
Contact details	25

Emergency telephone number:
0800 111 999*

*All calls are recorded and may be monitored

Disclaimer

This document is provided for use by third parties for safe working in the vicinity of National Grid high-pressure gas pipelines and associated installations.

Where this document is used by any other party it is the responsibility of that party to ensure that this document is correctly applied.

Mandatory and non-mandatory requirements

In this document:

shall: indicates a mandatory requirement.

should: indicates best practice and is the preferred option. If an alternative method is used then a suitable and sufficient risk assessment shall be completed to show that the alternative method delivers the same, or better, level of protection.

Introduction

Specification for safe working In the vicinity of National Grid high-pressure gas pipelines and associated installations – requirements for third parties

This specification is for issue to third parties carrying out work in the vicinity of National Grid high pressure gas pipelines (above 7 bar gauge) and associated installations and is provided to ensure that individuals planning and undertaking work take appropriate measures to prevent damage.

Any damage to a high-pressure gas pipeline or its coating can affect its integrity and can result in failure of the pipeline with potential serious hazardous consequences for individuals located in the vicinity. It is therefore essential that the procedures outlined in this document are complied with when working near to a high pressure pipeline. If any work is considered by National Grid to be in breach of the requirements stipulated in this document then the National Grid responsible person will suspend the work until the non-compliances have been rectified.

The Pipelines Safety Regulations state that “No person shall cause such damage to a pipeline as may give rise to a danger to persons” (Regulation 15). Failing to comply with these requirements could therefore also result in prosecution by the Health and Safety Executive (HSE).

The requirements in this document are in line with the requirements of the Institution of Gas Engineers and Managers (IGEM) recommendations IGE/SR/18 Edition 2 - Safe Working Practices To Ensure The Integrity Of Gas Pipelines And Associated Installations and the HSE’s guidance document HS(G)47 Avoiding Danger from Underground Services.

It is the responsibility of the third party to ensure that any work carried out also conforms with the requirements of the Construction and Design Management Regulations and all other relevant health and safety legislation.

Always contact National Grid prior to carrying out any work in the vicinity of a high pressure pipeline

CONTACT NATIONAL GRID

Contact National Grid on 0800 688588 to obtain formal consent - Section 2 of this document.

Note: at least 14 days notice prior to commencement of the work is normally required

CONSIDER SAFETY

Consider the safety requirements - Section 3 of this document.

INFORM NATIONAL GRID AND REQUEST PIPELINE LOCATION

Inform National Grid prior to carrying out work and arrange for National Grid to locate the pipeline - Section 4 of this document Note: at least 14 days notice is normally required

OBSERVE RESTRICTIONS

Observe National Grid restrictions on the allowed proximity of mechanical excavators and other power tools and the measures to protect the pipeline from construction vehicles when carrying out the work – Sections 5, 6 and 7 of this document.

Note: National Grid may wish to supervise the work, consult National Grid to confirm whether or not this is the case.

SPECIFIC ACTIVITIES

No-Dig Techniques
Change in Cover
Piling
Seismic Surveys

Hot Work
Blasting
Demolition
Surface Mineral Extraction

Landfilling
Pressure Testing
Deep Mining
Wind and Solar Farms

CONSULT NATIONAL GRID

Consult National Grid prior to any backfilling over, alongside or under the pipeline and obtain National Grid's agreement to proceed. Normally National Grid requires 48 hours notice prior to backfilling - Section 9 of this document.

IMPORTANT: This flowchart should be used in conjunction with the entire SSW22 document and not in isolation, AND if at any time during the works the pipeline is damaged even slightly then observe the precautions in Section 10 of this document.

IF IN DOUBT CONTACT NATIONAL GRID

1 Scope

This specification sets out the safety precautions and other conditions affecting the design, construction and maintenance of services, structures and other works in the vicinity of National Grid pipelines and associated installations operating at pressures greater than 7 bar gauge, located in both negotiated easements (see Section 12) and public highways.

The principles of this document should also be observed when carrying out work in the vicinity of intermediate pressure mains (pipelines operating between 2 and 7 bar gauge). In some circumstances some of the requirements of the document, when applied to intermediate pressure mains, may be relaxed but only with the prior agreement of National Grid.

2 Formal consent

High pressure pipelines are generally laid across country within an easement agreed with the landowner or within the highway.

As the required arrangements for working within an easement and working within the highway differ, this document has been structured to highlight the specific requirements for these two types of area where work may be carried out.

In Scotland a 'Deed of Servitude', known generally as a 'wayleave' is considered equivalent to 'easement' in this document.

Generally, normal agricultural activities are not considered to affect the integrity of the pipeline, however consult National Grid prior to undertaking deep cultivation in excess of 0.5 m.

In all other cases no work shall be undertaken in the vicinity of the pipeline without the formal written consent of National Grid.

Any documents handed to contractors, or other individuals undertaking work (e.g. farmer, local authority etc), on site by National Grid, shall be signed for by the site manager. National Grid will record a list of these documents using the form in Appendix A, and the contractor or other individuals undertaking work should maintain a duplicate list.

2.1 Within an easement

The promoter of any works (see Section 12) within an easement shall provide National Grid with details of the proposed works including a method statement of how the work is intended to be carried out.

Work shall not go ahead until formal written consent has been given by National Grid. This will include details of National Grid's protection requirements, contact telephone numbers and the emergency telephone number.

On acceptance of National Grid's requirements the promoter of the works shall give National Grid 14 days notice, or shorter only if agreed with National Grid, before commencing work on site.

2.2 Within the highway

Work shall be notified to National Grid in accordance with the requirements of The New Roads and Street Works Act (NRSWA) and HS(G)47.

The promoter of any works within the highway should provide National Grid with details of the proposed works including a method statement of how the work is intended to be carried out. This should be submitted 14 days before the planned work is to be carried out, or shorter only if agreed with National Grid. If similar works are being carried out at a number of locations in close proximity a single method statement should be adequate.

Work should not go ahead until formal written consent has been given by National Grid. This will include details of National Grid's protection requirements, contact telephone numbers and the emergency telephone number.

3 HS&E considerations

3.1 Safe control of operations

All working practices shall be agreed by National Grid prior to work commencing. All personnel working on site shall be made aware of the potential hazard of the pipeline and the actions they should follow in case of an emergency. The Site Document Control Form (Appendix A) should be used to record the list of relevant documents that have been provided by National Grid to persons undertaking work at the site.

3.2 Deep excavations

Special consideration should be given to the hazards associated with deep excavations. The HSE document CIS08 'Safety in Excavations' provides further guidance and is available on the HSE web site www.hse.gov.uk

3.3 Positioning of plant

Mechanical excavators and any other powered mechanical plant shall not be sited or moved above the pipeline unless written authority has been given by the National Grid responsible person.

Mechanical excavators and any other powered mechanical plant shall not dig on one side of the pipeline with the cab of the excavator positioned on the other side.

Mechanical excavators, any other powered mechanical plant, and other traffic shall be positioned far enough away from the pipeline trench to prevent trench wall collapse.

3.4 General

Works in the vicinity of high pressure pipelines may have an impact on the safety of the general public, site workers, National Grid staff and contractors, and may affect the local environment. Anyone (e.g. contractors, site workers, farmers, local authorities etc.) working close to the pipeline shall carry out suitable and adequate risk assessments prior to the commencement of work to ensure that all such issues are properly considered and risks mitigated.

4. Pipeline locating

Where formal consent to work has been given, the third party should give 14 working days notice, or shorter, if agreed with National Grid, to ensure that the pipeline is suitably located and marked out by National Grid prior to the work commencing.

Before commencing work on site, the pipeline shall be located and pegged or suitably marked out by National Grid personnel using pipeline location markers with triangular flags (see Appendix B) to indicate the presence of the pipeline. In exceptional circumstances and only with the prior agreement of National Grid, the locating and marking out of the pipeline could be carried out by competent third parties as long as National Grid is assured of their competence and the procedures to be followed.

Safe digging practices, in accordance with HSE publication HS(G)47 should be followed as both direct and consequential damage to gas plant can be dangerous both to employees and to the general public.

Previously agreed working practices should be reviewed and revised based on current site conditions. Any changes shall be agreed by the National Grid responsible person.

The requirements for trial holes to locate the pipeline or determine levels at crossing points shall be determined on site by the National Grid responsible person.

The excavation of all trial holes shall be supervised by the National Grid responsible person.



5 Slabbing and other protective measures

No protective measures including the installation of concrete slab protection shall be installed over or near to the National Grid pipeline without the prior permission of National Grid. National Grid will need to approve the material, the dimensions and method of installation of the proposed protective measure. The method of installation shall be confirmed through the submission of a formal written method statement from the contractor to National Grid.

Where permanent slab protection is to be applied over the pipeline, National Grid will normally carry out a coating survey of the pipeline to check that there is no existing damage to the coating of the pipeline prior to the slab protection being put in place. National Grid shall therefore be given suitable advance notice (typically 14 working days) prior to the laying of any slab protection to arrange for them to carry out this survey.

The Safety precautions detailed in Sections 3 and 6 of this document should also be observed during the installation of the pipeline protection.



6 Excavation

6.1 In Proximity to a pipeline in an easement

Third parties may excavate, unsupervised, with powered mechanical plant no closer than 3 metres to the National Grid pipeline as long as the pipeline has been clearly located and marked out by National Grid staff. Due to the potential of toothed excavator buckets to damage pipelines, toothless buckets shall be used. Any fitting, attachment or connecting pipework on the pipeline shall be exposed by hand. All other excavation shall be by hand.

Consideration may be given to a relaxation of these limits by agreement with the National Grid responsible person on site, provided the pipeline position has been confirmed by hand-dug trial holes and only whilst the National Grid responsible person remains on site.

Where sufficient depth of cover exists, following evidence from hand dug trial holes, light tracked vehicles may be permitted to strip topsoil to a depth of 0.25 metres, using a toothless bucket.

No topsoil or other materials shall be stored within the easement without the written permission of National Grid.

Figure 1. Excavation restrictions

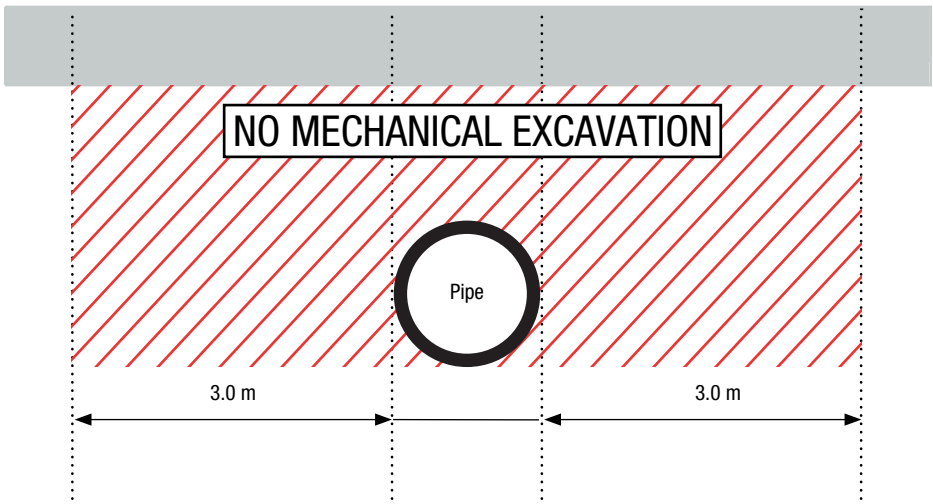

No fires are allowed in the easement strip or close to above ground gas installations.

After the completion of the work the level of cover over the pipeline should be the same as that prior to work commencing, unless agreed otherwise with the National Grid responsible person.

No new service shall be laid parallel to the pipeline within the easement. In special circumstances, and only with formal written agreement from National Grid, this may be relaxed for short excursions where the service shall be laid no closer than 0.6 metres to the side of the pipeline.

Where work is being carried out parallel to the pipeline within or just alongside the easement a post and wire fence shall be erected as a protective barrier between the works and the pipeline.

National Grid may require that an easement crossing agreement (deed of indemnity) be completed by the third party prior to the commencement of work. This shall be discussed with the National Grid responsible person prior to the commencement of the works.

6.2 In proximity to a pipeline in the highway

Removal of the bituminous or concrete highway surface layer by mechanical means is permitted to a depth of 0.3 metres, although the use of chain trenchers to do this is not permitted within 3 metres of the pipeline. The National Grid responsible person may monitor this work.

Where the bituminous or concrete highway surface layer extends below 0.3 metres deep, it shall only be removed by handheld power assisted tools under the supervision of the National Grid responsible person. In exceptional circumstances, and following a risk assessment, these conditions may be relaxed by the National Grid responsible person.

Third parties may excavate, unsupervised, with powered plant mechanical plant no closer than 3 metres to the located National Grid pipeline. Any fitting or attachment shall be exposed by hand.

In special circumstances consideration may be given to a relaxation of these rules by agreement with the National Grid responsible person on site and only whilst they remain on site.

The use of 'No dig' techniques is covered in Section 8.1.

Any new service running parallel to the pipeline should be laid no closer than 0.6 metres to the side of the pipeline (see Section 6.4).

6.3 Crossing over a pipeline

Where a new service is to cross over the pipeline, a clearance distance of 0.6 metres between the crown of the pipeline and underside of the service should be maintained. If this cannot be achieved, the service shall cross below the pipeline, see section 6.4.

In special circumstances, this distance may be reduced at the discretion of the National Grid responsible person on site.

6.4 Crossing below a pipeline

Where a service is to cross below the pipeline, a clearance distance of 0.6 metres between the crown of the service and underside of the pipeline shall be maintained.

Where lengths of pipeline greater than one metre are to be exposed, the National Grid responsible person shall be consulted to establish any support requirements. Any supports shall be removed prior to backfilling.

The exposed pipeline/s shall be protected by matting and suitable timber cladding.



6.5 Cathodic protection

Cathodic Protection is applied to National Grid's buried steel pipelines and is a method of protecting pipelines from corrosion by maintaining an electrical potential the pipeline and anodes placed at strategic points along the pipeline.

Where a new service is to be laid and similarly protected, National Grid will undertake interference tests to determine whether the new service is interfering with the cathodic protection of the National Grid pipeline.

Should any cathodic protection posts or associated apparatus need moving to facilitate third party works, appropriate notice, at least 14 days, shall be given to National Grid. National Grid will undertake this work and any associated costs will be borne by the third party.

6.6 Installation of electrical equipment

Where electrical equipment is being installed close to National Grid's buried steel pipelines, the effects of a rise of earth potential under fault conditions shall be considered by the third party and a risk assessment shall be submitted to National Grid for approval, prior to the works.

7 Construction traffic

Where existing roads cannot be used, construction traffic should ONLY cross the pipeline at previously agreed locations. All crossing points will be fenced on both sides with a post and wire fence and with the fence returned along the easement for a distance of 6 metres. The pipeline shall be protected, at the crossing points,

by temporary rafts constructed at ground level. The third party shall review ground conditions, vehicle types and crossing frequencies to determine the type and construction of the raft required. The type of raft shall be agreed with National Grid prior to installation.

Figure 2. Construction traffic requirements

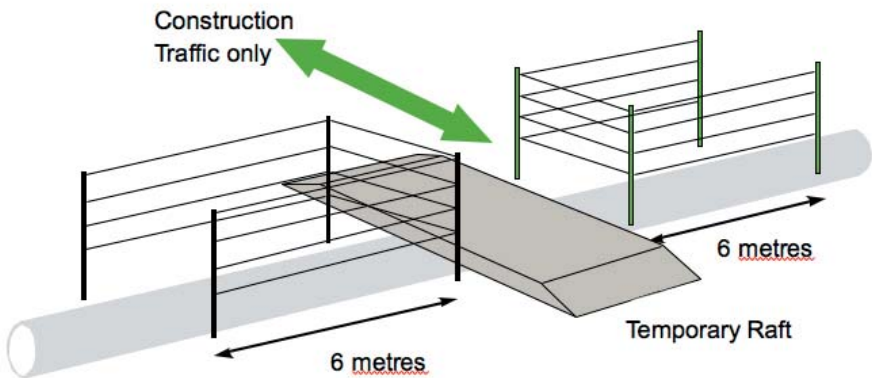

8 Specific activities

This section details the precautions that need to be taken when carrying out certain prescribed activities in the vicinity of the pipeline. Consult National Grid if you are intending to undertake one of the listed prescribed activities and/or you require further advice on whether the work that you are intending to undertake has the potential to affect the pipeline.

The table below shows, for some specific activities, the prescribed distances within which the advice of National Grid shall be sought (see Sections 8.1 to 8.13 for further details):

Activity	Distance within which National Grid advice shall be sought
Piling	15 m
Surface Mineral Extraction	100 m
Landfilling	100 m
Demolition	150 m
Blasting	250 m
Deep Mining	1000 m
Wind Turbine	Not permitted within 1.5 times the turbine mast height from the nearest edge of a pipeline (please see www.ukopa.co.uk)

8.1 No-dig techniques

Where the third party (e.g. contractor, farmer, local authority, site worker etc.) intends using no dig techniques then a formal method statement shall be produced for all work that would encroach (either above or below ground) within the pipeline easement. This method statement shall be formally agreed with National Grid prior to the commencement of the work. National Grid may wish to be present when the work is being carried out and shall therefore be given adequate advance notice before the commencement of the work.

8.2 Changes to depth of cover

8.2.1 Increase in Cover

A pipeline integrity assessment shall be provided for situations involving a final cover depth exceeding 2.5 metres. This assessment should take due account of soil 'dead' loading, ground settlement due to earthworks and the impact of the increased cover on National Grid's ability to inspect and maintain the pipeline. Embankment design and construction over pipelines shall give consideration to prevention of any instability. Expert advice may need to be sought which can be arranged through National Grid.

8.2.2 Reduction in Cover

The depth of cover over National Grid's pipeline shall not be reduced. National Grid shall be consulted for any activity proposed that will lead to a reduction in cover over the pipeline. Expert advice may need to be sought which can be arranged through National Grid.

8.3 Piling

No piling shall be allowed within 15 metres of a pipeline without an assessment of the vibration levels at the pipeline. The peak particle velocity at the pipeline shall be limited to a maximum level of 75 mm/sec. Where the peak particle velocity is predicted to exceed 50 mm/sec, the ground vibration shall be monitored by the contractor and the results available to the National Grid responsible person at their request.

Where ground conditions include silt or sand, an assessment of the effect of vibration on settlement and liquefaction at the pipeline shall be made.

Expert advice may need to be sought which can be arranged through National Grid.

8.4 Demolition

No demolition should be allowed within 150 metres of a pipeline without an assessment of the vibration levels at the pipeline. The peak particle velocity at the pipeline shall be limited to a maximum level of 75 mm/sec. Where the peak particle velocity is predicted to exceed 50 mm/sec, the ground vibration shall be monitored by the contractor and the results available to the National Grid responsible person at their request.

Where ground conditions include silt or sand, an assessment of the effect of vibration on settlement and liquefaction at the pipeline shall be made.

Expert advice may need to be sought which can be arranged through National Grid.

8.5 Blasting

No blasting should be allowed within 250 metres of a pipeline without an assessment of the vibration levels at the pipeline. The peak particle velocity at the pipeline shall be limited to a maximum level of 75 mm/sec. Where the peak particle velocity is predicted to exceed 50 mm/sec, the ground vibration shall be monitored by the individual/company undertaking the work and the results available to the National Grid responsible person at their request.

Where ground conditions include silt or sand, an assessment of the effect of vibration on settlement and liquefaction at the pipeline shall be made.

Expert advice may need to be sought which can be arranged through National Grid.

8.6 Surface mineral extraction

An assessment shall be carried out on the effect of surface mineral extraction activity within 100 metres of a pipeline. Consideration should also be given to extraction around other pipeline associated plant and equipment.

Where the mineral extraction extends up to the pipeline easement, a stable slope angle and stand-off distance between the pipeline and slope crest

shall be determined by National Grid. The easement strip should be clearly marked by a suitable permanent boundary such as a post and wire fence, and where appropriate, slope indicator markers shall be erected to facilitate the verification of the recommended slope angle as the slope is formed, by the third party. The pipeline easement and slope needs to be inspected periodically to identify any signs of developing instability. This may include any change of slope profile including bulging, the development of tension cracks on the slope or easement, or any changes in drainage around the slope. The results of each inspection should be recorded.

Where surface mineral extraction activities are planned within 100 metres of the pipeline but do not extend up to the pipeline easement boundary, an assessment, by National Grid shall be made on whether the planned activity could promote instability in the vicinity of the pipeline. This may occur where the pipeline is routed across a natural slope or the excavation is deep. A significant cause of this problem is where the groundwater profile is affected by changes in drainage or the development of lagoons.

Where the extraction technique involves explosives the provisions of section 8.5 apply.

8.7 Deep Mining

Pipelines routed within 1 km of active deep mining may be affected by subsidence resulting from mineral extraction. The determination of protective or remedial measures will normally require expert assistance, which can be arranged through National Grid.

8.8 Landfilling

The creation of slopes outside of the pipeline easements may promote instability within the vicinity of the pipeline. An assessment should therefore be carried out, by National Grid, on the effect of any landfilling activity within 100 metres of a pipeline. The assessment is particularly important if landfilling operations are taking place on a slope in which the pipeline is routed.

8.9 Pressure testing

Hydraulic testing of a third party pipeline should not be permitted within 6 metres either side of a National Grid pipeline, to provide protection against the effects of a burst.

Where this cannot be achieved, typically where the third party pipeline needs to cross a National Grid pipeline, one of the following precautions would need to be adopted:

- a) limiting of the design factor of the third party pipeline to 0.3 at the pipeline's nominated maximum operating pressure (MOP), and the use of pre-tested pipe.
- or b) the use of sleeving.

In either case, the third party shall submit of their proposed precautions and method statement for National Grid consideration.

8.10 Seismic surveys

National Grid shall be advised of any seismic surveying work in the vicinity of pipeline that will result in National Grid's pipeline being subjected to peak particle velocities in excess of 50 mm/sec. The ground vibration near to the pipeline shall also be monitored by the contractor whilst the survey work is being carried out. Where the peak particle velocity is predicted to exceed 50 mm/sec, the ground vibration should be monitored by the contractor and the results available to the National Grid responsible person at their request.

8.11 Hot work

The National Grid responsible person on site should supervise all welding, burning or other 'hot work' that takes place within the easement.

8.12 Wind Turbines

Wind turbines shall not be sited any closer than 1.5 times the proposed height of the turbine mast away from the nearest edge of the pipeline.

8.13 Solar Farms

Solar Farms can be built adjacent to pipelines but never within the easement. Advice shall be sought from National Grid at the early stages of design to ensure that electrical interference, security, future access and construction methods can be mutually agreed.

9 Backfilling

No backfilling should be undertaken without National Grid agreement to proceed. The National Grid responsible person will stipulate the necessary consolidation requirements.

Individuals/Contractors/companies/organisations undertaking work shall provide National Grid with 48 hours notice, or shorter notice only if agreed with National Grid, of the intent to backfill over, under or alongside the pipeline. This requirement should also apply to any backfilling operations alongside the pipeline within 3 metres of the pipeline.

Minor damage to pipe coating and test leads will be repaired by National Grid free of charge.

Any damage to the pipeline or coating shall be reported to the National Grid responsible person in order that damage can be assessed and repairs can be carried out.

If the pipeline has been backfilled without the knowledge of the National Grid responsible person, they will require the material to be re-excavated in order to enable the condition of the pipeline coating to be confirmed.

10 Action in the case of damage to the pipeline

If the National Grid pipeline is damaged, even slightly, and even if no gas leak has occurred then the following precautions shall be taken immediately:-

- Shut down all plant and machinery and extinguish any potential sources of ignition.
- Evacuate all personnel from the vicinity of the pipeline.
- Notify National Grid using the free 24 hour emergency telephone number

0800 111 999*

***All calls are recorded and may be monitored**

- Notify the National Grid responsible person or his office immediately using the contact telephone number provided.

- Ensure no one approaches the pipeline.

- Do not try to stop any leaking gas.

11 References

NRSA	New Roads & Street Works Act
HS(G)47	HSE Guidance 'Avoiding Danger from Underground Services'
IGE/SR/18	Safe Working Practices to Ensure the Integrity of Gas Pipelines and Associated Installations (Institution of Gas Engineers)
CIS08	Safety in Excavations (HSE document – see HSE website www.hse.gov.uk)

12 Glossary of terms

Deed of Servitude: In Scotland a 'Deed of Servitude' is considered equivalent to 'easement' in this document.

Easement: Easements are negotiated legal entitlements between National Grid and landowner and allow National Grid to lay, operate and maintain pipelines within the easement strip. Easement strips may vary in width typically between 6 and 25 metres depending on the diameter and pressure of the pipeline. Consult National Grid for details of the extent of the easement strip where work is intended.

Liquefaction: Liquefaction is a phenomenon in which the strength and stiffness of the soil is reduced by earthquake shaking or other rapid loading. Liquefaction occurs in saturated soils, that is, soils in which the space between individual particles is completely filled with water. When liquefaction occurs, the strength of the soil decreases and the ability of the soil to support pipelines or other components is reduced.

Promoter of works: The person or persons, firm, company or authority for whom new services, structures or other works in the vicinity of existing National Grid pipelines and associated installations operating above 7 bar gauge are being undertaken.

National Grid responsible person:

The person or persons appointed by National Grid with the competencies required to act as the National Grid representative for the purpose of managing the particular activity

Wayleave: General term which is considered equivalent to 'easement' in this document.

Appendix A

Site Document Control Form - Sample

EMERGENCY TELEPHONE NO. 0800 111 999*		NATIONAL GRID
SITE DOCUMENT CONTROL FORM		
ACTIVITY REFERENCE:		
ACTIVITY LOCATION:		
SITE MANAGER:		
NATIONAL GRID CONTACT:		
THE FOLLOWING DOCUMENTS WERE ISSUED TO <i>(INDIVIDUAL'S NAME)</i> OF <i>(COMPANY NAME AND ADDRESS)</i> BY <i>(NATIONAL GRID REPRESENTATIVE)</i> ON <i>(DATE)</i> DOCUMENTS: <i>(LIST OF DOCUMENTS)</i>		
Signed: <i>(by the recipient)</i>		Date of signature:

* All calls are recorded and may be monitored

Site Document Control Form

EMERGENCY TELEPHONE NO. 0800 111 999*		NATIONAL GRID
SITE DOCUMENT CONTROL FORM		
ACTIVITY REFERENCE:		
ACTIVITY LOCATION:		
SITE MANAGER:		
NATIONAL GRID CONTACT:		
THE FOLLOWING DOCUMENTS WERE ISSUED TO		
OF		
BY		
ON (DATE)		
DOCUMENTS:		
Signed:		Date of signature:

* All calls are recorded and may be monitored

Appendix B

Pipeline Location Flags

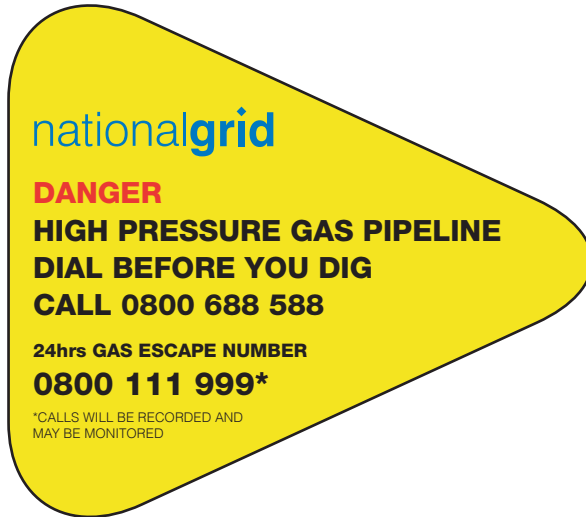

National Grid contact details:

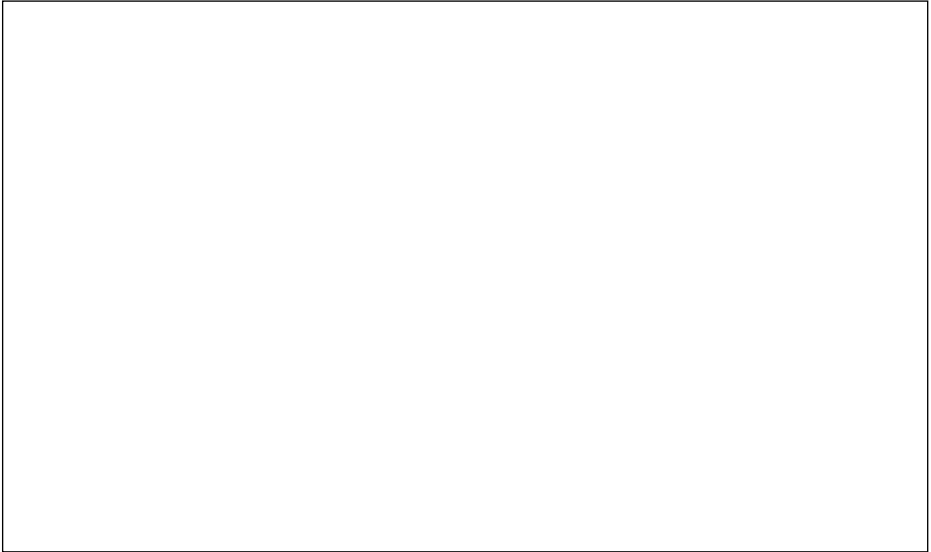

EMERGENCY TELEPHONE NO.

0800 111 999*

Copyright National Grid plc 2014 ©, all rights reserved. No part of this publication may be reproduced in any material form (including photocopying and restoring in any medium or electronic means and whether or not transiently or incidentally) without the written permission of National Grid plc except in accordance with the provisions of the Copyright, Designs and Patents Act 1988.

© National Grid plc 2014
All rights reserved.

SELF SERVICE FOR PLANT ENQUIRIES:

www.beforeyoudig.nationalgrid.com

This is a free online enquiry service giving results within minutes from a grid reference, postcode or street name. This site allows you to submit enquiries about activities and work that you are planning, which may have an impact on the National Grid Gas Distribution and Transmission Gas and Electricity Networks.

www.linesearchbeforeudig.co.uk

This is a free online enquiry service giving instant results from a grid reference, postcode or street name. If your result is within a National Grid zone of interest, you can click directly through to www.beforeyoudig.nationalgrid.com.

NOTE: Linesearch service is not available for all National Grid Pipelines. Therefore, please click on the National Grid link or call Plant Protection to ensure you have all the available information.

EMERGENCY

If you hit the pipeline, whether the damage is visible or not, or in the event of an emergency, call the National Gas Emergency Service immediately on

0800 111 999*

*CALLS WILL BE RECORDED
AND MAY BE MONITORED

National Grid Plant Protection Team

☎ 0800 688 588*

✉ plantprotection@nationalgrid.com

✉ National Grid Plant Protection

National Grid Block 1
Brick Kiln Street
Hinckley LE10 0NA

T/SP/SSW/22
April 2014



Printed on recycled paper