

## 5. ECCAF Update



Paul Wakeley – National Grid  
JESG | 17 December 2013

## Items covered at first meeting – 21 November

---

- Background to ECCAF
- Election of Chair
- Development process and status of ENCs
- Implementation in GB (DECC)
- Requirements for Generators
- High-level mapping of ENCs to GB Codes
- Future Meetings
- Long term structures of Codes (Garth)

## Background to ECCAF

---

- There are 9 European Network Codes due to become law during 2014 in a phased manner.
- GB will have 18 months – 3 years to demonstrate compliance (varies code-by-code)
- Alignment with GB Codes will aid application and compliance
- GB Code panels will retain their role to make changes to individual codes – strong feedback from all parties to use existing processes
- **A complex programme with a significant risk, which needs cross GB code coordination**

## European Code Coordination Application Forum

---

- **Advises the Code Panels on matters of coordination of application of European Network Codes to GB Codes**
- No firm legal or governance role
- Constituted as a joint standing group of 7 code panels
  - Grid Code, CUSC, BSC, SQSS, STC, D-Code, DCUSA
- Membership:
  - 7 industry members representing Code Panels
  - National Grid, Consumer Futures, DECC, Ofgem
  - Chair appointed by members
  - Technical Secretary / Admin provided by National Grid

# GB Code Governance

---

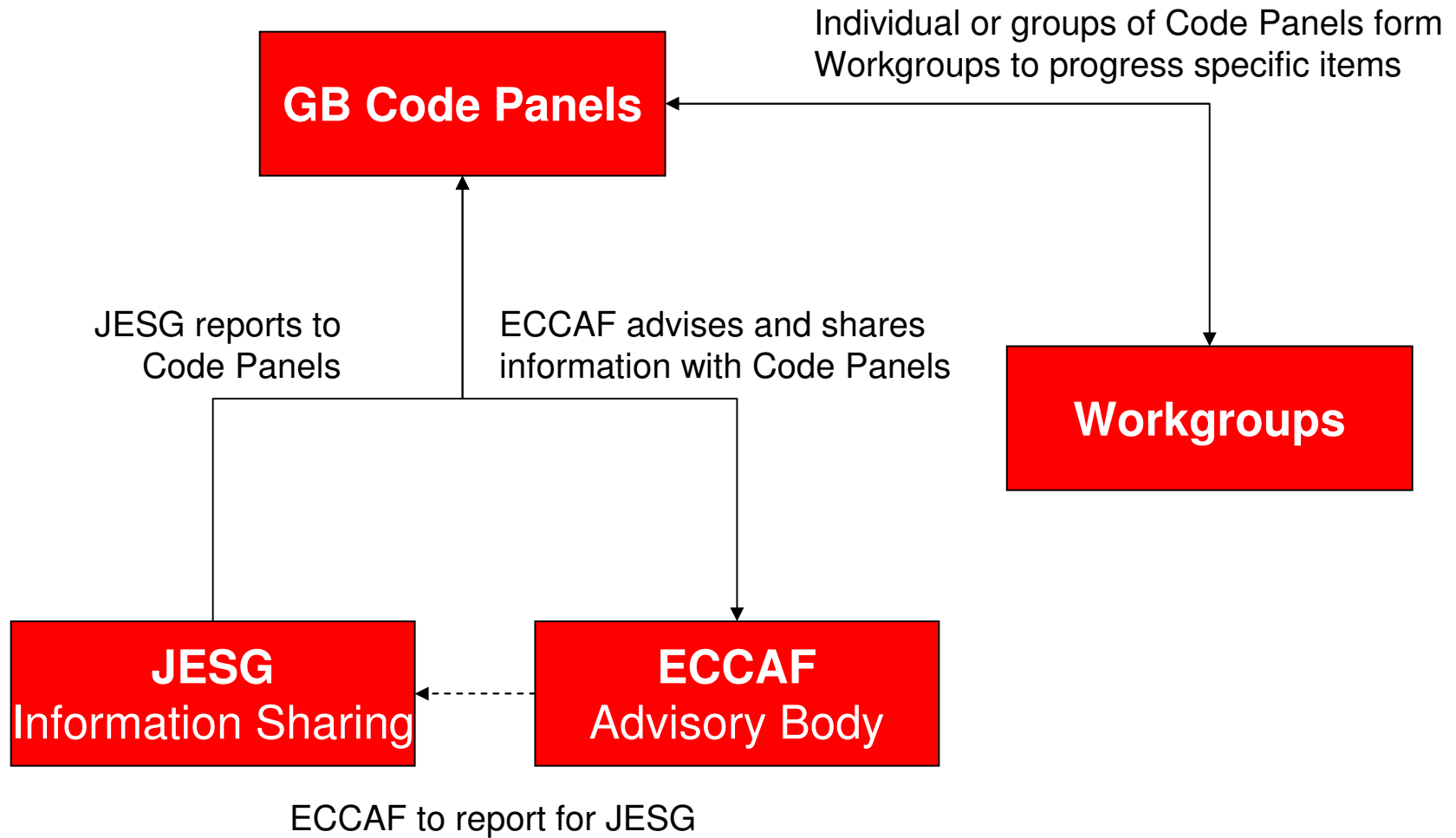

## Where does ECCAF fit

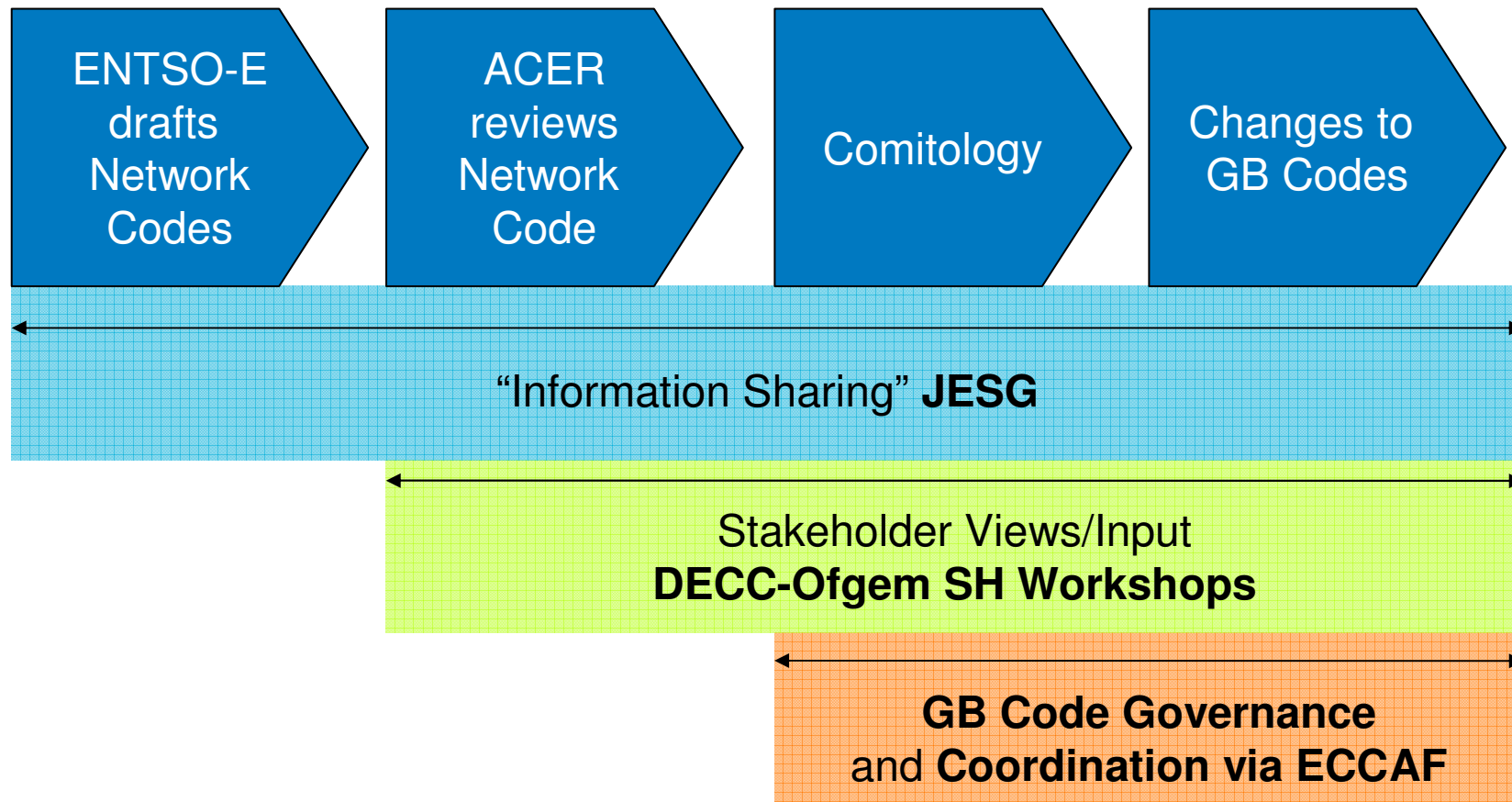

## Membership

---

■ <b>Barbara Vest</b>	EnergyUK	BSC Panel
■ <b>Garth Graham</b>	SSE	CUSC Modification Panel
■ <b>Mike Kay</b>	ENWL	D-Code Review Panel
■ <b>Chris Allanson</b>	Northern Powergrid	DCUSA Panel
■ <b>Joseph Dunn</b>	SPT	STC Panel
■ Vacant		SQSS Panel
■ <b>Carole Hook / Bec Thornton</b>		National Grid
■ <b>Fiona Navesey</b>		DECC
■ <b>Adid Sheikh</b>		Ofgem
■ <b>Paul Wakeley</b>		Technical Secretary

## Membership

---

- Other industry parties can attend as observers by notification to the Technical Secretary
  
- **Changes to membership**
  - Peter Waymont, UK Power Networks is now the DCUSA Rep
  - The BSC Panel have been invited to nominate another member as Barbara is now the Chair



## Election of Chair

---

- DECC and Ofgem had indicated that their wishes the members of ECCAF to elect the chair at their first meeting.
- Barbara Vest of Energy UK was duly elected

## Implementation in GB (DECC)



# Implementation Instruments



Department of Energy & Climate Change

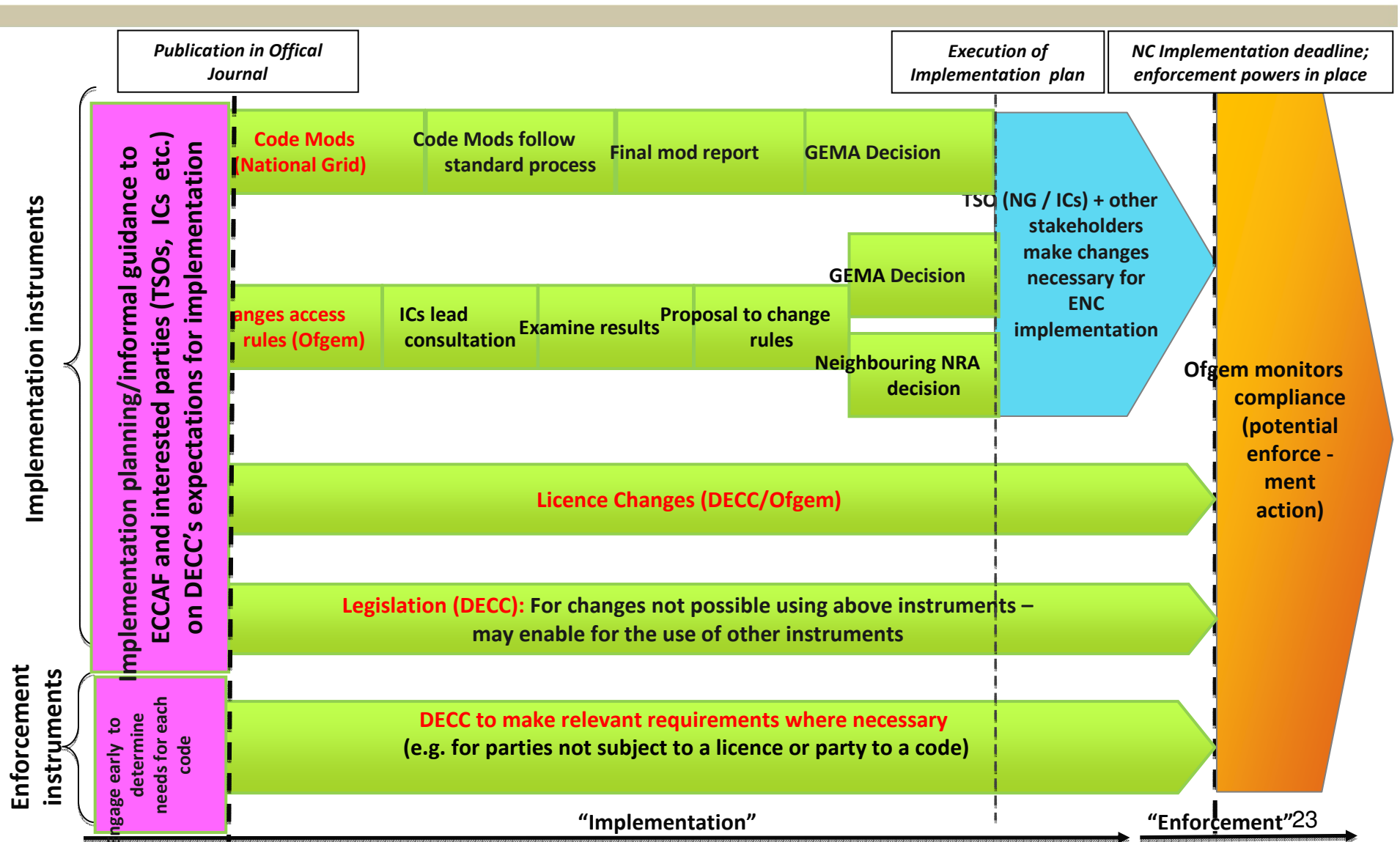

## Requirements for Generators

---

- Rob Wilson, NGET, updated on options for applying the RFG to Grid Code and the D-Code.
- Recall that RFG has 4 bandings from 800W upwards
- GB Grid Code has 'Small, Medium and Large' which vary between NGET, SPT and SHET
- D-Code has different obligations based on voltages.
  
- A future areas of consideration for ECCAF and the joint DCRP/GCRP Workgroup which is being formed.

# Mapping of ENCs to GB Codes

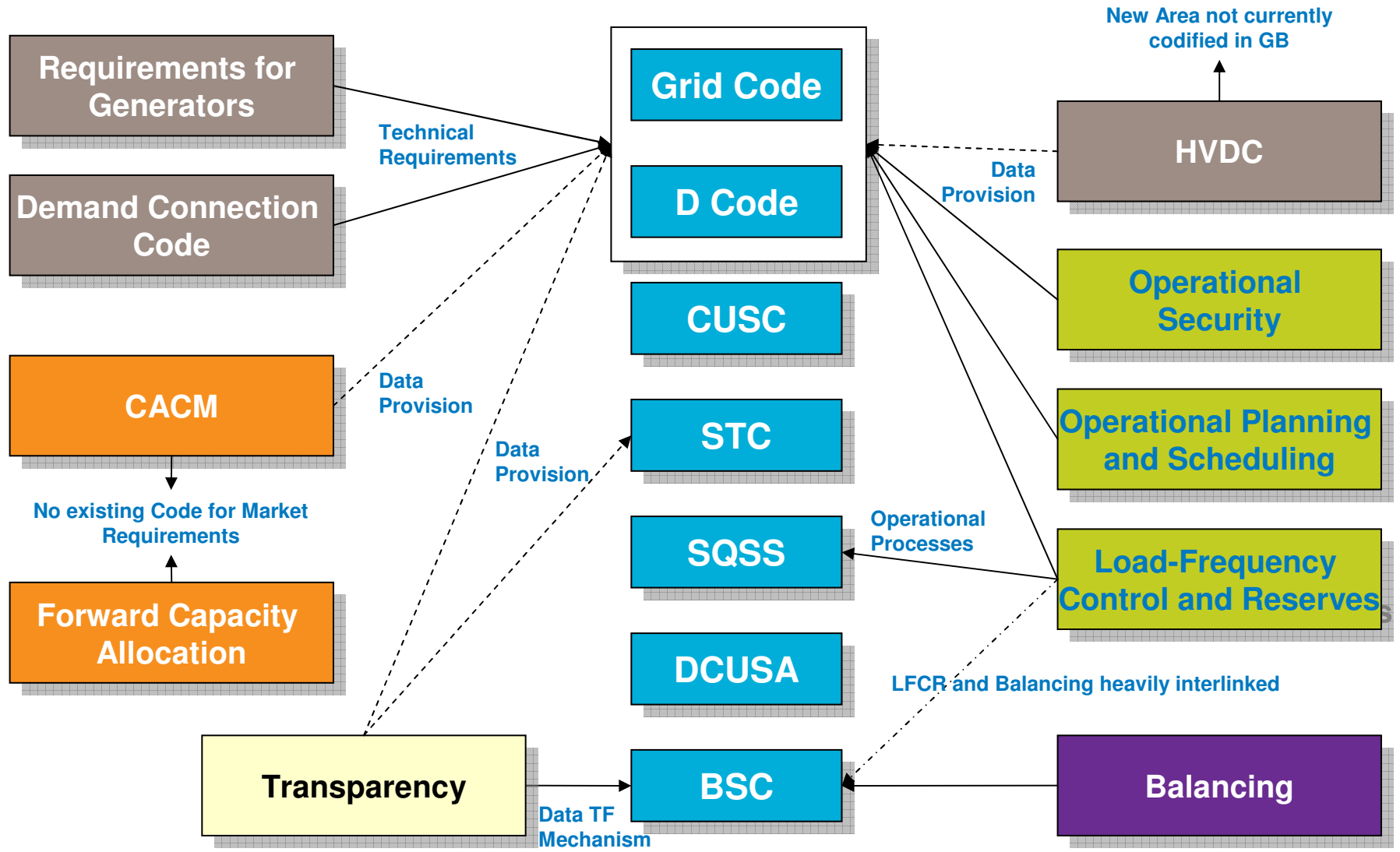

## Future meeting items

---

- Meetings are expected to be held monthly
- Agenda items for January Meeting:
  - Overall GB Code Structure discussion (including criteria).
  - Process for application and engagement (high-level strategy).
  - Ensuring consistency in the application of multiple ENCs to multiple GB Codes.
  - ECCAF Workplan to drive future agenda items, expecting to broadly consider Code in order of progress through the development / approval process.

## Implementation in GB Codes – A Strawman

---

- Garth Graham, SSE