

Technical RfG Sub Meeting
Proposed Issues for JESG log

14th December 2011 – Elexon's Euston Offices

- The RfG drafting team has prepared justification documents for the Network Code. Is National Grid intending to produce a GB specific justification?
- What is the formal governance process for the setting of TSO parameters?
- The upper voltage operating limit is currently 15 minutes in Grid Code but in the RfG it has been increased to 20 min
- What is the impact going to be of the RfG on GB Codes other than the Grid Code/ Distribution Code? E.g. STC/ CUSC
- What were the assumptions behind the minimum Fault Ride Through (FRT) obligations for sub 132kV network?
 - If FRT obligations are going to be applied to Type B and Type C generators where is the positive Cost Benefit Analysis?
- The definition for "Generating Unit" is confusing – for both Synchronous and PPMs
- Has the phrase "Significant" been correctly interpreted from the Framework Guidelines?
- Some attendees questioned whether the methodology/ criteria for determining the boundaries between Types (e.g A,B,C,D) should be in the RfG Network Code
- What happens when there is a common/ shared Point of Connection? e.g. Cruachan and Ffestiniog

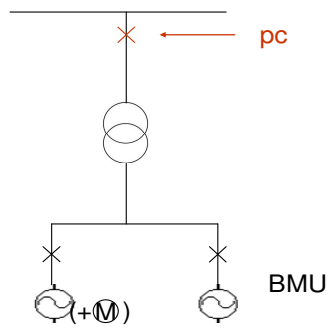

- The proposed rate of change of frequency withstand is 2 Hz/sec for 1.25s
- Who will own the Dynamic System Monitoring (DSM) equipment? (Fault recorders)
- **Auto-reclosure** obligations have changed (8-2(a))