

**Good Industry Practice
Safety Co-ordinator Training**

**Recommended Safety Co-ordinator
Training**

Presentation & Guidance Notes

These notes are intended as an additional information package for training Control Persons to enact the role of Safety Co-ordinators across interface boundaries with TLs, Generators, DNOs and any other outside agencies where interaction across Control Boundaries is necessary.

Important Note

- This package has been developed by a multi user group from Generators, DNOs & TLs
- Users have the responsibility to provide competent individuals to carry out their company's Grid Code responsibilities
- It is the Users responsibility to interpret this guidance to meet their own company's requirements
- This guidance is based on the Grid Code Issue 3 revision 11 of 15th July 2005

Contents

No. of Slide	
4	Glossary of Terms
6	Objectives
10	Recommended Minimum Standards
12	Boundaries
19	OC8 / RI SSP Philosophy
28	More Complex Issues
30	Other Considerations
40	RI SSP Issue
46	RI SSP Cancellation
47	RI SSP Examples
59	Case Studies
61	Learning Points

Version 2.0

Glossary of Terms / 1

These terms are for guidance only. Where applicable, refer to the Grid Code Glossary for the definitive description

- **DOA:** Delegation of Authority. A contractual agreement between two companies that allows one Control Person to delegate control of defined equipment to the Control Person of another company for establishing safety precautions. Referred to as an Agency Agreement or Operational Arrangements.
- **DNO:** Distribution Network Operator (formerly a Regional Electricity Company in England & Wales)
- **HV:** High Voltage. Typically above a 1000 volts
- **OC8:** That part of the Grid Code defining RI SSPs
- **OC8A & OC8B:** OC8A operates in England & Wales. OC8B operates in Scotland
- **PFW:** Permit for Work. A company specific safety document that controls work

Version 2.0

4

The emphasis of this presentation is concentrating on the role of the Safety Co-ordinator.

The Control Person has a host of duties but when co-ordinating safety across control boundaries the duties become interlinked with other Control Persons of different systems.

Awareness of the increased responsibility must be stressed.

The additional information required by the Control Person to act as Safety Co-Ordinator across Control Boundaries will be covered in this presentation

Glossary of Terms / 2

These terms are for guidance only. Where applicable, refer to the Grid Code Glossary for the definitive description

- **RISSP:** Record of Inter System Safety Precautions
- **Safety Co-ordinator:** A suitably qualified and trained person, nominated by an appropriate officer of his / her employing company to be responsible for the co-ordination of safety precautions at their connection point as defined in OC8 of the Grid Code
- **Sanction:** A company specific safety document that allows testing & removal of earths
- **SRS:** Site Responsibility Schedule
- **STC:** The System Operator Transmission Code which defines arrangements with National Grid & the Scottish Transmission Owners
- **TL:** Transmission Licensee. One of, National Grid, SP Transmission Ltd or Scottish Hydro Electricity Transmission Ltd

Version 2.0

5

The emphasis of this presentation is concentrating on the role of the Safety Co-ordinator.

The Control Person has a host of duties but when co-ordinating safety across control boundaries the duties become interlinked with other Control Persons of different systems.

Awareness of the increased responsibility must be stressed.

The additional information required by the Control Person to act as Safety Co-Ordinator across Control Boundaries will be covered in this presentation

Objectives

This presentation aims to clarify what the
Safety Co-ordinator needs to understand when:

Enacting the role of HV Safety Co-ordinator
across a Generator/DNO/TL interface

Objectives

Objectives are to understand:

- The minimum standards required
- Responsibilities as Safety Co-ordinator
- Site Responsibility Schedules
- OC8 of the Grid Code and the RI SSP process
- Enacting the role of Safety Co-ordinator

Objectives

When enacting this role it is important that the Safety Co-ordinator does so in a professional manner by following the correct procedures and discharging the duties in such a way as to instill confidence and respect

It is important to get it right

Version 2.0

8

It must be stressed at this point that the intention is to produce Safety Co-ordinators who are of the right calibre and project the proper image as ambassadors of the company to other persons.

A professional approach sends the right messages and a complete knowledge of the systems and procedures should be demonstrated.

Evidence indicates that we have not always got it right. This will be discussed later when we view some case studies.

Objectives

Using this guidance, Companies are encouraged to set their own standards for the 'Training and Nomination of Safety Co-ordinators' within their own Safety Management Systems and Procedures

Version 2.0

9

It is therefore important that the nomination to the role of Safety Co-Ordinator should not be given lightly.

The training received by the individuals undertaking this role should reflect the importance of the position.

All sites should follow a similar approach to training so that a common standard is achieved.

At this stage the introduction notes from the minimum standards document are to be issued to support the next eight slides

Recommended Minimum Standards

- Safety Co-ordinator duties should be recognised as a key function by all parties
- Appropriate training shall be given, and supported by the appropriate evidence
- Responsibilities are to be discharged in a responsible, professional manner

Recommended Minimum Standards

When enacting the role of Safety Co-ordinator at any User interface the responsibilities are:

1. Consulting with the appropriate Safety Co-ordinators to agree, initiate and record those actions necessary to establish and maintain safety precautions on Plant and Apparatus which is interconnected across the control boundary and the management of Proximity PFWs
2. Implementing the agreed procedure for recording inter-system safety precautions (RI SSP) procedure

Version 2.0

11

The primary responsibility as a Safety Co-ordinator is to manage safety across the Control Boundary through liaison and consultation with your peers within the interfacing organisations.

Boundaries

Control, Safety Rule & Ownership Boundaries

Version 2.0

12

The following slides go into more detail on how Safety Co-ordination across Control Boundaries works in practise.

Boundaries

Site Responsibility Schedules Define for the Assets:-

- The Owner
- The Site Manager
- Safety Rules & Safety Co-ordinator
- Operational Procedures & Control or Other Responsible Engineer
- Statutory inspections / maintenance responsibilities
- Remarks that define any exceptions

Version 2.0

13

The Site Responsibilities Schedule should be kept such that it is available to all who work and co-ordinate activities across Control Boundaries.

Each Control Person on any site should have access to and be intimate with the information it contains.

They must be aware of where their own responsibilities lie within the schedule.

The Schedule must be kept up to date and be in good condition.

Other Responsible Engineer: as referred to in the Grid Code Connection Conditions Appendix 1.

Boundaries

Site Responsibility Schedules

- Will define the Control Boundary
- Will define the Safety Rule Boundary
- Will define the Ownership Boundary
- Will define the Maintenance Boundary

The Safety Co-ordinator's Role is across the Control Boundary

Version 2.0

14

These four boundaries are effectively the limits of the Sphere of Operation of each Safety Co-ordinator.

The detail of where the boundaries are is very precise and all the Company Control Persons enacting the Safety Co-ordinator role should be intimate with this information.

Boundaries

Control & Safety Rule Boundaries

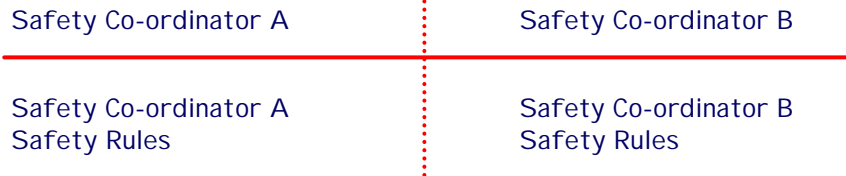

The Control and Safety rule boundaries may be one and the same

Version 2.0

15

It can be seen here that the boundary may be one of Control and Safety as well as Ownership and Maintenance.

Safety Co-ordinators should understand where each boundary is physically, who is the Control Person and whose rules apply.

Boundaries

Control & Safety Rule Boundaries

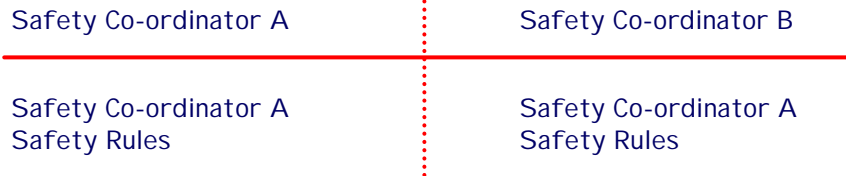

The same safety rules may be in force both sides of the boundary

Version 2.0

16

It can be seen here that the boundary may be one of Control and Safety as well as Ownership and Maintenance.

Safety Co-ordinators should understand where each boundary is physically, who is the Control Person and whose rules apply.

Boundaries

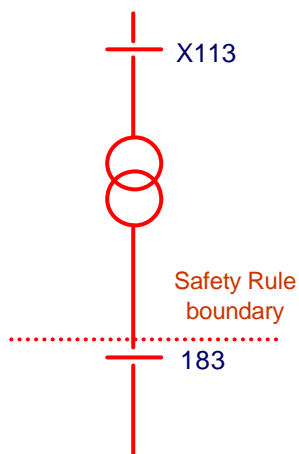

Safety Rule Boundary Example

Work required on
Transformer and 183

TL is the Control person for
both assets

The TL would consent to PFW
on Transformer and the PFW
for 183 but to the other
party's safety rules

Version 2.0

17

In the case of Safety Rules boundaries this example shows that although the Control Person for both the Transformer and 183 is a TL person the work will be covered by different Safety Documents. The TL will issue a PFW on the transformer obtaining consent from their own Operations Centre, and another company may issue a PFW on 183 but again consent from the TL will be required.

Boundaries

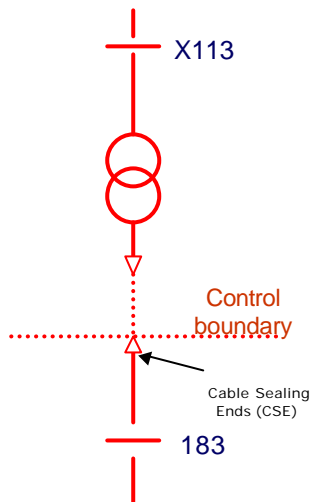

Complex Control Boundary Example

Work required on CSEs at the boundary

Two RI SSPs & PFWs required

One PFW will be consented to by the TL

The other party will consent the second PFW

Version 2.0

18

For work across a Control Boundary on the cable sealing ends both parties require similar control measures from each other and so both Safety Co-ordinators will be requesting and implementing RISSP's and both will be consenting to the issue of safety documents by the other parties.

OC8 / RI SSP Philosophy

Grid Code OC8 (RI SSP Procedure)

Version 2.0

19

The following 23 slides cover the requirements of the RI SSP procedure. Preferably a copy of OC8 or reference to the flow charts and the guidance in the Minimum Standards document should be available to the course members for reference.

OC8 / RI SSP Philosophy

What is a RI SSP?

Record of I nter - S ystem S afety P recautions

- RI SSP – I (Implementing RI SSP)
- RI SSP – R (Requesting RI SSP)

Version 2.0

20

The differences between the types of RI SSP is covered later.

Safety Co-ordinators should be aware that they may well be involved with both.

OC8 / RISSP Philosophy

Purpose of OC8

- The TLs act as a intermediaries carrying power between generators and customers, certain equipment must cross control boundaries
- The Grid code OC8 specifies the method of achieving and maintaining safety when working on such equipment

Version 2.0

21

The statement as read

OC8 / RISSP Philosophy

The Basic Principles

The Safety Rules each company operate specify that before work can be carried out on High Voltage Equipment it must be:

- Dead
- Isolated from the live system
- Earthed between the point of isolation and point of work
- Released for work by issue of a Safety Document

Version 2.0

22

Some basic Safety Rules reminders to be emphasised

OC8 / RISSP Philosophy

Where safety precautions provided on one system are recorded across a control boundary, they may subsequently be used for the preparation of safety documents, subject to limitations on testing, without further reference

Version 2.0

23

This emphasises the importance of the RISSP procedure as a safety precautions function and the speaker must reiterate that the security and control of the RISSP documents must be without compromise.

OC8 / RISSP Philosophy

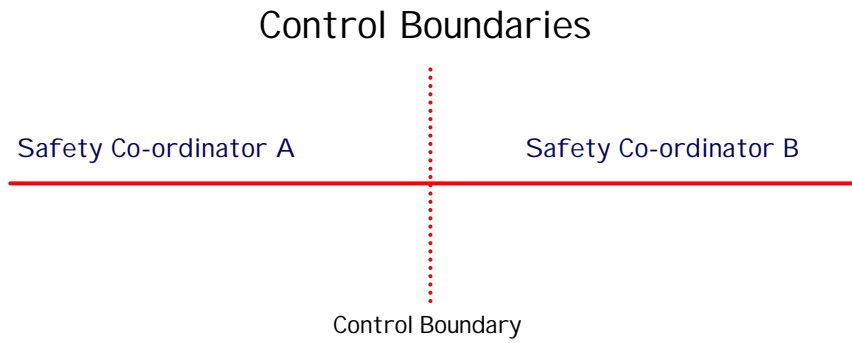

There can only be two Safety Co-ordinators
interfacing across a control boundary

Version 2.0

24

As read

OC8 / RISSP Philosophy

Simple example

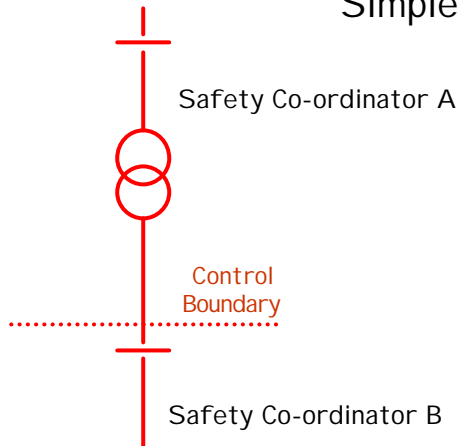

Work required on Safety Co-ordinator A Transformer

Co-ordinator A incapable of instructing all required precautions

Communication with Safety Co-ordinator B to Request safety from his system

Version 2.0

25

Safety Co-ordinator A will become the Requesting Safety Co-ordinator requiring safety precautions to be effected by Safety Co-ordinator B, the Implementing Safety Co-ordinator, on those parts of the system that are under the control of Safety Co-ordinator B.

OC8 / RISSP Philosophy

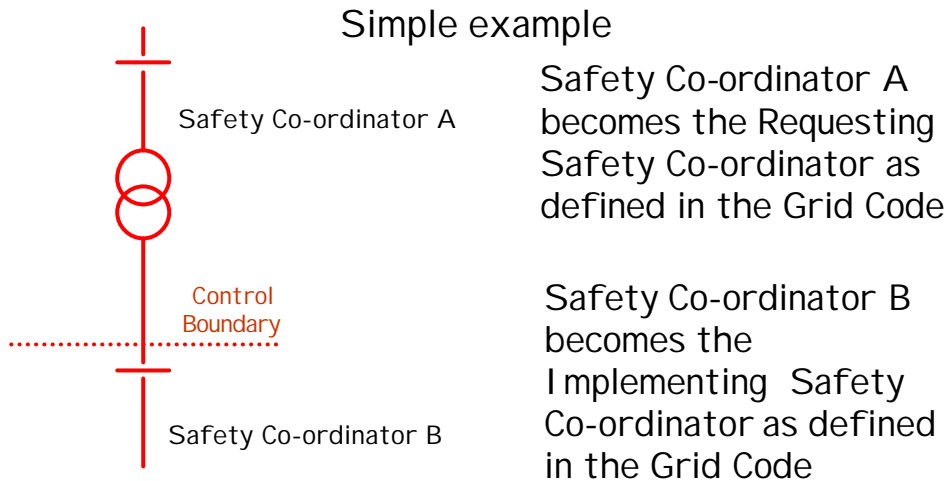

Version 2.0

26

Safety Co-ordinator A will become the Requesting Safety Co-ordinator requiring safety precautions to be effected by Safety Co-ordinator B, the Implementing Safety Co-ordinator, on those parts of the system that are under the control of Safety Co-ordinator B.

OC8 / RISSP Philosophy

Points to note

- There is no requirement for either Safety Co-ordinator to know the details of the circuit beyond the boundary
- Only the name and location of the circuit is required
- If work is required on both sides of the boundary then each Safety Coordinator enacts the role of Requester and Implementer, as they are both providing safety precautions for each other
- Each piece of HV equipment connected to the system must be under the control of someone who the Grid Code describes as a Safety Co-ordinator or other Responsible Engineer

Version 2.0

27

Each Safety Co-ordinator relies on the other Safety Co-ordinator to be fully aware of the safety precautions required to provide Safety From the System across the boundary to allow work on the other's apparatus.

More Complex Issues

Cascade of Precautions

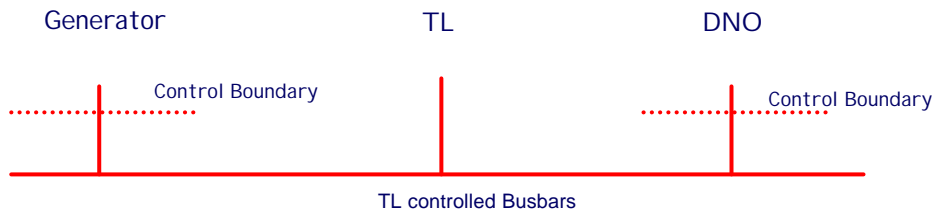

Generators rarely have to Cascade RISSPs as they do not control the busbars. Ref. OC8.5.1.2

The Same Principle as in the simple example i.e. only two Safety Co-ordinators interface at any boundary point.

The TL requests precautions from one Safety Co-ordinator which are cascaded via an implementing RI SSP to another.

If all three parties are working at the same time there will be four RISSPs in place.

Version 2.0

28

In this example the TL Safety Co-ordinator may well be interfacing across a number of boundaries to achieve Safety From the System and enacting the role of both requesting and implementing Safety Co-ordinator.

There would be no interface between the Generator Safety Co-ordinator and the Distribution Network Operator (DNO) Safety Co-ordinator. The TL acts as the middle man. If DNO require precautions from the Generator they would obtain these through interface with the TL.

Depending on the work any number of RISSPs could be in force.

More Complex Issues

Linkage of Safety Precautions Ref. OC8.5.1.3

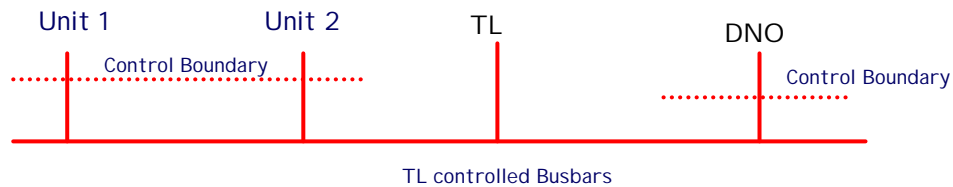

When the TL are acting as an Implementing Safety Co-ordinator for work on Unit 1 they inform the Generator Safety Co-ordinator that safety can only be guaranteed if safety is maintained on his own Unit 2 Circuit.

The Generator Safety Co-ordinator may not have a Busbar diagram available

Version 2.0

29

In this example the TL Implementing Safety Co-ordinator is informing the Generator Requesting Safety Co-ordinator, as required in OC8, of other precautions required to provide Safety From the System from other H.V. systems.

Other Considerations

- The STC now allows precautions to be cascaded through the RI SSP procedure, where the former British Grid System Agreement did not allow this
- Testing Across Control Boundaries (OC8.6)
- Emergency Situations (OC8.7)
- Proximity PFW (OC8.8)
- Exchange of Keys

Version 2.0

30

As read

Other Considerations: Testing

TESTING ACROSS CONTROL BOUNDARIES

Version 2.0

31

Other Considerations: Testing

Testing across Control Boundaries

Points to note:

- 1. Testing across a Control Boundary is carried out under a specific safety document**
- 2. The Requesting Safety Co-ordinator must inform the implementing Safety Co-ordinator when intending to test across a Control Boundary**

Other Considerations: Testing

Testing across control boundaries

- 3. All other Safety Documents must be cancelled and only the testing Safety Document shall be in force across the boundary**
- 4. The intention to test across a Boundary will be recorded with the Implementing Safety Co-ordinator**
- 5. Only one Requesting / Implementing RI SSP will be in force**

Version 2.0

33

Other Considerations: Testing

Testing across control boundaries

- 6. When parties have agreed that testing can take place the holder of the testing safety document may remove the earths quoted on the RISSP**
- 7. When testing, the safety control of the whole zone passes to the recipient of the Testing Safety Document, this overrides that specified in the Site Responsibility Schedule.**

Other Considerations: Testing

Cancellation of Testing Requirements

- 1. When testing is complete the Implementing Safety Co-ordinator will be contacted to record the cancellation of the testing requirements**
- 2. The status of the equipment transferred during the testing shall be recorded on cancellation of the RI SSP**
- 3. When a Testing Document is cancelled with an exception which invalidates the RI SSP, the RI SSP will be cancelled without delay**

Other Considerations: Emergencies

- Grid Code OC8.7

Where there is an inadvertent connection between systems, this part of the Grid Code defines how the safety precautions & RI SSP process will be controlled

Version 2.0

36

The following slides take a step by step approach to implementing the RI SSP procedure.

Other Considerations: Proximity PFW Ref. OC8.8

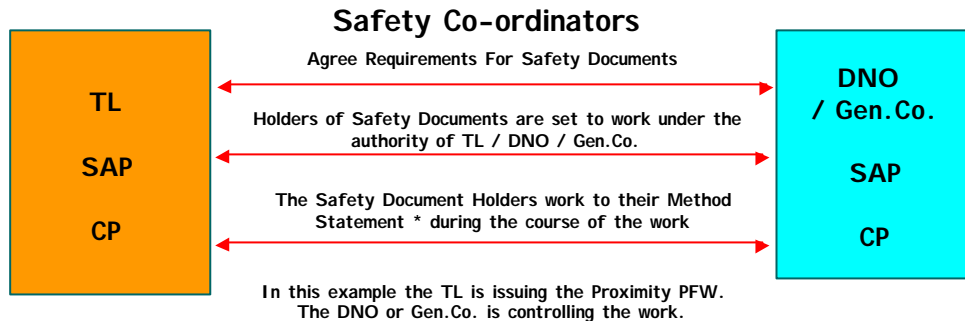

*Under Regulation 3 of the Management of Health & Safety at Work Regulations any significant risk must be recorded

It is the responsibility of the person controlling the work to ensure the method statement is correct.
This will include control measures required by the TL, whose HV equipment is being infringed.

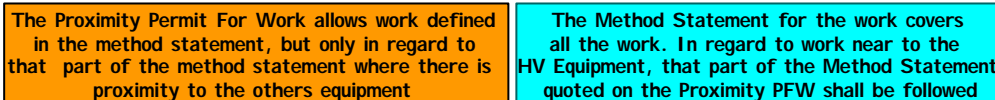

TL: Transmission Licensee

SAP: Senior Authorised Person, that person authorised by a company to issue safety documents

CP: Competent Person. The holder of the Proximity PFW and leader of the working party for the whole job

Version 2.0

37

One method statement controls the complete job. The Proximity PFW is the method by which the risk from the HV equipment is managed.

The Proximity PFW quotes the part of the method statement that defines how the risk from the HV equipment being infringed is managed.

Managing the job in this way defines exactly who has responsibility for managing the hazards throughout the work.

The SAP issuing the proximity PFW only has input into that part of the method statement associated with the hazard from the HV equipment.

Other Considerations: Proximity PFW

Where a RI SSP is in force for the TL to maintain the Super Grid bus bar selector isolator and the DNO controls the bus bars, the Implementing RI SSP from the DNO provides adequate safety precautions for the work on the Super Grid bus bar selector isolators

A Proximity PFW is only issued where safety distances could be infringed to HV equipment not electrically connected. For example a radio mast adjacent to a circuit

Other Considerations: Key Safe Keys

Where reasonably practicable Key Safe Keys securing isolation and any earthing must be given to a site representative of the Requesting Safety Co-ordinator

THE RI SSP PROCEDURE

The following slides take a step by step approach to implementing the RISSP procedure.

RISSP Issue

General Requirements

Dialogue is required between Safety Co-ordinators to clarify:

- The equipment to be worked on
- The safety precautions required
- If Delegation of Authority of the Control Person Role, (DOA) is to be given or received
- This dialogue should be logged in the location Safety log
- Continuous 24 hrs. availability is a Grid Code requirement, but give as much notice as possible

Version 2.0

41

This is the preamble part of the procedure.

Delegation of authority should only be given to Control Persons authorised to act as such on the equipment concerned.

A record of the DOA and its rescinding should be kept by both parties.

RISSP Issue

Specific Requirements

- All Parties must establish and confirm that Isolations are in place.
- Only when all Isolations are confirmed can the Safety Co-ordinators agree to the application of Earths.
- Confirmation may only be received or given between the Safety Co-ordinators, not other site staff.

Version 2.0

42

The RISSP procedure must follow the same protocol as all other H.V. switching procedures.

Isolation followed by earthing.

It is important that intermediaries are not used as part of this process.

RISSP Issue

Specific Requirements

- Details of Isolations and Earths in place will be recorded in the HV Switching Logs
- Only when all isolations and earths (where applicable) are in place and secure can the respective RISSP forms be completed
- In the Control Person's role a key from the Key Safe securing the isolation may be retained with the Implementing RISSP if deemed Reasonably Practicable

Version 2.0

43

As previous

RISSP Issue

Specific Requirements

- Safety precautions may only be cascaded to another party when they have been recorded on a Requesting RI SSP
- Even when the precautions have been established under a DOA they cannot be cascaded to another party without being recorded on a RI SSP

Version 2.0

44

The RISSP procedure must be complete including the securing of the documents and any keys transferred before the precautions can be cascaded to other parties.

RI SSP Issue

- Both types of RI SSP Form carry the same information
- They are completed at the same time by both the Requesting and Implementing Safety Co-ordinators
- Follow the same protocol as a Switching Instruction.

Version 2.0

45

As read

RI SSP Cancellation

When safety precautions are no longer required, (i.e. all work complete on the Requesting side of the boundary and any Safety documents cancelled), the Requesting Safety Co-ordinator will contact the Implementing Safety Co-ordinator to effect cancellation of the RI SSP

- Each party then co-ordinates the removal of safety precautions (earths followed by isolation) and then return to service of the circuit

RISSP Examples
OC8A
 The RI SSP-R Form
 Requesting Safety
 Co-ordinators Record.
 Front View

OC8A - APPENDIX A

(NGET) [] CONTROL CENTRE/SITE]

RECORD OF INTER-SYSTEM SAFETY PRECAUTIONS (RISSP-R)
 (Requesting Safety Co-ordinator's Record)

RISSP NUMBER []

PART 1

1.1 HV APPARATUS IDENTIFICATION

Safety Precautions have been established by the Implementing Safety Co-ordinator (or by another User on that User's System connected to the Implementing Safety Co-ordinator's System) to achieve (in so far as it is possible from that side of the Connection Point) Safety From The System on the following HV Apparatus on the Requesting Safety Co-ordinator's System (State density - name(s) and, where applicable, identification of the HV circuit(s) up to the Connection Point).

Further Safety precautions required on the Requesting Safety Co-ordinator's System as notified by the Implementing Safety Co-ordinator.

1.2 SAFETY PRECAUTIONS ESTABLISHED

(a) **ISOLATION**

[State the Location(s) at which Isolation has been established (whether on the Implementing Safety Co-ordinator's System or on the System of another User connected to the Implementing Safety Co-ordinator's System). For each Location, identify each point of Isolation. For each point of Isolation, state the means by which the Isolation has been achieved, and whether, immobilised and Locked, Caution Notice affixed, other safety procedures applied, as appropriate.]

(b) **EARTHING**

[State the Location(s) at which Earthing has been established (whether on the Implementing Safety Co-ordinator's System or on the System of another User connected to the Implementing Safety Co-ordinator's System). For each Location identify each point of Earthing. For each point of Earthing, state the means by which Earthing has been achieved, and whether, immobilised and Locked, other safety procedures applied, as appropriate.]

1.3 ISSUE

I have received confirmation from _____ (name of Implementing Safety Co-ordinator) at _____ (location) that the Safety Precautions identified in paragraph 1.2 have been established and that instructions will not be issued at this location for their removal until this RISSP is cancelled.

Signed _____ Requesting Safety Co-ordinator)
 at _____ (time) on _____ (Date)

PART 2

2.1 CANCELLATION

I have confirmed to _____ (name of the Implementing Safety Co-ordinator) at _____ (location) that the Safety Precautions set out in paragraph 1.2 are no longer required and accordingly the RISSP is cancelled.

Signed _____ Requesting Safety Co-ordinator)
 at _____ (time) on _____ (Date)

Version 2.0

As previous

RISSP Examples
OC8A
 The RI SSP-I Form
 Implementing Safety
 Co-ordinator's Record.
 Front view

OC8A - APPENDIX B

(NGE) [] CONTROL CENTRE(SITE)

RECORD OF INTER-SYSTEM SAFETY PRECAUTIONS (RISSP-I)
Implementing Safety Co-ordinator's Record

PART 1 RISSP NUMBER []

1.1 HV APPARATUS IDENTIFICATION

Safety Precautions have been established by the Implementing Safety Co-ordinator (or by another User on that User's System connected to the Implementing Safety Co-ordinator's System) to achieve (in so far as it is possible from that side of the Connection Point) Safety From The System on the following HV Apparatus on the Requesting Safety Co-ordinator's System (State identity - name(s) and, where applicable, identification of the HV circuit(s) up to the Connection Point):

Recording of notification given to the Requesting Safety Co-ordinator concerning further Safety Precautions required on the Requesting Safety Co-ordinator's System.

1.2 SAFETY PRECAUTIONS ESTABLISHED

(a) ISOLATION

[State the Location(s) at which Isolation has been established (whether on the Implementing Safety Co-ordinator's System or on the System of another User connected to the Implementing Safety Co-ordinator's System). For each Location, identify each point of Isolation. For each point of Isolation state the means by which the Isolation has been achieved, and whether, immobilised and Locked, Caution Notice affixed, other safety procedures applied, as appropriate.]

(b) EARTHING

[State the Location(s) at which Earthing has been established (whether on the Implementing Safety Co-ordinator's System or on the System of another User connected to the Implementing Safety Co-ordinator's System). For each Location identify each point of Earthing. For each point of Earthing state the means by which Earthing has been achieved, and whether, immobilised and Locked, other safety procedures applied, as appropriate.]

1.3 ISSUE

I have confirmed to [] (name of Requesting Safety Co-ordinator) at [] (location) that the Safety Precautions identified in paragraph 1.2 have been established and that instructions will not be issued at my location for their removal until this RISSP is cancelled.

Signed [] (Implementing Safety Co-ordinator)
 at [] (time) on [] (Date)

PART 2

2.1 CANCELLATION

I have received confirmation from [] (name of the Requesting Safety Co-ordinator) at [] (location) that the Safety Precautions set out in paragraph 1.2 are no longer required and accordingly the RISSP is cancelled.

Signed [] (Implementing Safety Co-ordinator)
 at [] (time) on [] (Date)

(Note: This form to be of a different colour from RISSP-R)

Version 2.0

48

The details of the form need to be discussed Briefly.
 How to fill it in follows later.
 Hand out blank copies of RISSP I & Rs.

RI SSP Examples: OC8A

The Location Name

The RI SSP number as quoted by the Requesting Safety Co-ordinator

Identification of the HV Apparatus to be worked on and circuits up to the connection point, agreed by both Safety Co-ordinators

Details of apparatus that in the opinion of the Implementing Safety Co-ordinator should be included in the Safety Precautions taken and reported to the Requesting Safety Co-ordinator

OC8A - APPENDIX A

(NGET) _____ (CONTROL CENTRE/SITE)

RECORD OF INTER-SYSTEM SAFETY PRECAUTIONS (RISSP-R)
(Requesting Safety Co-ordinator's Record)

RISSP NUMBER: _____

PART 1

1.1 HV APPARATUS IDENTIFICATION

the Connection Point Safety From The system on the following HV Apparatus on the Requesting Safety Co-ordinator's System: (State identity - name(s) and, where applicable, identification of the HV circuit(s) up to the Connection Point)

Further Safety precautions (required on the Requesting Safety Co-ordinator's System as notified by the Implementing Safety Co-ordinator):

1.2 SAFETY PRECAUTIONS ESTABLISHED

(a) **ISOLATION**

[State the Location(s) at which Isolation has been established (whether on the Implementing Safety Co-ordinator's System or on the System of another User connected to the Implementing Safety Co-ordinator's System). For each Location, identify each point of Isolation. For each point of Isolation state the means by which Isolation has been achieved, and whether immobilised and Locked Caution Notice affixed, other safety procedures applied, as appropriate.]

(b) **EARTHING**

[State the Location(s) at which Earthing has been established (whether on the Implementing Safety Co-ordinator's System or on the System of another User connected to the Implementing Safety Co-ordinator's System). For each Location identify each point of Earthing. For each point of Earthing state the means by which Earthing has been achieved, and whether immobilised and Locked other safety procedures applied, as appropriate.]

1.3 ISSUE

I have received confirmation from _____ (name of Implementing Safety Co-ordinator) at _____ (location) that the Safety Precautions identified in paragraph 1.2 have been established and that instructions will not be issued at this location for their removal until this RISSP is cancelled.

Signed _____ (Requesting Safety Co-ordinator)
at _____ (time) on _____ (Date)

PART 2

2.1 CANCELLATION

I have confirmed to _____ (name of the Implementing Safety Co-ordinator) at _____ (location) that the Safety Precautions set out in paragraph 1.2 are no longer required and accordingly the RISSP is cancelled.

Signed _____ (Requesting Safety Co-ordinator)
at _____ (time) on _____ (Date)

Version 2.0

This section needs to be used when carrying out the role play exercise.

RISSP Examples: OC8A

Details of Safety Precautions established and secured by the Implementing Safety Co-ordinator

It is the Implementing Safety Co-ordinator's responsibility to state the precautions held

Details of Earths applied & confirmed as above

The Implementing Safety Coordinator states the earths applied for the Requesting Safety Co-ordinator's benefit

OC8A - APPENDIX B

(NGET) _____ (CONTROL CENTRE/SITE)

RECORD OF INTER-SYSTEM SAFETY PRECAUTIONS (RISSP-I)
(Implementing Safety Co-ordinator's Record)

PART 1 RISSP NUMBER _____

1.1 HV APPARATUS IDENTIFICATION

Safety Precautions have been established by the Implementing Safety Co-ordinator (or by another User on that User's _____)

Recording of notification given to the Requesting Safety Co-ordinator concerning further Safety Precautions required on the Requesting Safety Co-ordinator's System _____

1.2 SAFETY PRECAUTIONS ESTABLISHED

(a) **ISOLATION**

(State the Location(s) at which Isolation has been established (whether on the Implementing Safety Co-ordinator's System or on the System of another User connected to the Implementing Safety Co-ordinator's System). For each Location, identify each point of Isolation. For each point of Isolation state the means by which the Isolation has been achieved, and whether, immobilised and Locked, Caution Notice affixed, other safety procedures applied, as appropriate.)

(b) **EARTHING**

(State the Location(s) at which Earthing has been established (whether on the Implementing Safety Co-ordinator's System or on the System of another User connected to the Implementing Safety Co-ordinator's System). For each Location identify each point of Earthing. For each point of Earthing, state the means by which Earthing has been achieved, and whether, immobilised and Locked, other safety procedures applied, as appropriate.)

1.3 **ISSUE**

I have confirmed to _____ (name of Requesting Safety Co-ordinator) at _____ (location) that the Safety Precautions identified in paragraph 1.2 have been established and that instructions will not be issued at my location for their removal until this RISSP is cancelled.

Signed _____ (Implementing Safety Co-ordinator)

at _____ (time) on _____ (Date)

PART 2

2.1 **CANCELLATION**

I have received confirmation from _____ (name of the Requesting Safety Co-ordinator) at _____ (location) that the Safety Precautions set out in paragraph 1.2 are no longer required and accordingly the RISSP is cancelled.

Signed _____ (Implementing Safety Co-ordinator)

at _____ (time) on _____ (Date)

(Note: This form to be of a different colour from RISSP-R)

Version 2.0

50

As previous.

RI SSP Examples: OC8A

Both Requesting and Implementing Safety Co-ordinators shall complete and sign part 1.3 of the RI SSP-R and RI SSP-I forms respectively.

Once signed no alterations are permitted The RI SSP can only be cancelled

When safety precautions are no longer required, (i.e. all work complete and any Safety documents Cancelled), the Requesting Safety Co-ordinator will contact the Implementing Safety Coordinator to effect cancellation of the RI SSP

OC8A - APPENDIX A

(INGET) _____ (CONTROL CENTRE/SITE)

RECORD OF INTER-SYSTEM SAFETY PRECAUTIONS (RISSP-R)
(Requesting Safety Co-ordinator's Record)

RISSP NUMBER

PART 1

1.1 HV APPARATUS IDENTIFICATION

The Connection Point Safety From The System on the following HV Apparatus on the Requesting Safety Co-ordinator's System (State identity - name(s) and, where applicable, identification of the HV circuit(s) up to the Connection Point):

Further Safety precautions required on the Requesting Safety Co-ordinator's System as notified by the Implementing Safety Co-ordinator:

1.2 SAFETY PRECAUTIONS ESTABLISHED

(a) **ISOLATION**

[State the Location(s) at which Isolation has been established (whether on the Implementing Safety Co-ordinator's System or on the System of another User connected to the Implementing Safety Co-ordinator's System). For each Location, identify each point of Isolation. For each point of Isolation, state the means by which the Isolation has been achieved, and whether, immobilised and Locked, Caution Notice affixed, other safety procedures applied, as appropriate.]

(b) **EARTHING**

[State the Location(s) at which Earthing has been established (whether on the Implementing Safety Co-ordinator's System or on the System of another User connected to the Implementing Safety Co-ordinator's System). For each Location identify each point of Earthing. For each point of Earthing, state the means by which Earthing has been achieved, and whether, immobilised and Locked, other safety procedures applied, as appropriate.]

1.3 ISSUE

I have received confirmation from _____ (name of Implementing Safety Co-ordinator) at _____ (location) that the Safety Precautions identified in paragraph 1.2 have been established and that instructions will not be issued at this location for their removal until this RISSP is cancelled.

Signed: _____ Requesting Safety Co-ordinator

at _____ (time) on _____ (Date)

PART 2

2.1 CANCELLATION

I have confirmed to _____ (name of the Implementing Safety Co-ordinator) at _____ (location) that the Safety Precautions set out in paragraph 1.2 are no longer required and accordingly the RISSP is cancelled.

Signed: _____ Requesting Safety Co-ordinator

at _____ (time) on _____ (Date)

Version 2.0

51

As previous.

RECORD OF INTER-SYSTEM SAFETY PRECAUTIONS (RISSP-R)
(Requesting Safety Co-ordinator's Record)

RISSP NUMBER _____

Part 1

1.1

CIRCUIT IDENTIFICATION

Safety Precautions have been established by the Implementing Safety Co-ordinator or to achieve Safety From The System on the following HV Apparatus:

1.2

SAFETY PRECAUTIONS ESTABLISHED

(a) ISOLATION

State the Locations(s) at which Isolation has been established on the Implementing Safety Co-ordinator's System. For each Location, identify each point of Isolation. For each point of Isolation state, the means by which the Isolation has been achieved, and whether, immobilised and Locked, Caution Notice affixed, other Safety Precautions applied, as appropriate.

RISSP Examples: OC8B

OC8 B

The RISSP-R FORM

Requesting Safety

Co-ordinator's Record.

Front view

The details of the form need to be discussed Briefly.

How to fill it in follows later.

Hand out blank copies of RISSP I & Rs.

RISSP Examples: OC8B

The RISSP-R FORM
Requesting Safety
Co-ordinator's Record.
Rear View

OC8B - APPENDIX A

(b) EARTHING

State the Locations(s) at which Earthing has been established on the Implementing Safety Co-ordinator's System. For each Location, identify each point of Earthing. For each point of Earthing state, the means by which the Earthing has been achieved, and whether, immobilised and Locked, other Safety Precautions applied, as appropriate.

1.3 ISSUE

I have received confirmation from _____ (name of Implementing Safety Co-ordinator) at _____ (Location) that the Safety Precautions identified in paragraph 1.2 have been established and that instructions will not be issued at his Location for their removal until this RISSP is cancelled.

Signed (Requesting Safety Co-ordinator)
at (time) on (date)

PART 2

2.1 CANCELLATION

I have confirmed to _____ (name of the Implementing Safety Co-ordinator) at _____ (Location) that the Safety Precautions set out in paragraph 1.2 are no longer required and accordingly the RISSP is cancelled.

Signed (Requesting Safety Co-ordinator)
at (time) on (date)

Version 2.0

53

RECORD OF INTER-SYSTEM SAFETY PRECAUTIONS (RISSP-I)
(Implementing Safety Co-ordinator's Record)

RISSP NUMBER _____

RISSP Examples: OC8B

PART 1

1.1 CIRCUIT IDENTIFICATION

Safety Precautions have been established by the Implementing Safety Co-ordinator to achieve Safety From The System on the following HV Apparatus:

1.2 SAFETY PRECAUTIONS ESTABLISHED

(a) ISOLATION

State the Location(s) at which isolation has been established on the Implementing Safety Co-ordinator's System. For each Location, identify each point of Isolation. For each point of Isolation state, the means by which the Isolation has been achieved, and whether, immobilised and Locked, Caution Notice affixed, other Safety Precautions applied, as appropriate.

The RISSP-I FORM
Requesting Safety
Co-ordinator's Record.
Front view

OC8B- APPENDIX B

RISSP Examples: OC8B

The RISSP-I FORM
Requesting Safety
Co-ordinator's Record.
Rear view

(b) EARTHING

State the Location(s) at which Earthing has been established on the Implementing Safety Co-ordinator's System. For each Location, identify each point of Earthing. For each point of Earthing state, the means by which the Earthing has been achieved, and whether, immobilised and Locked, other Safety Precautions applied, as appropriate.

1.3 ISSUE

I confirm d to _____ (name of Requesting Safety Co-ordinator) at _____ (Location) that the Safety Precautions identified in paragraph 1.2 have been established and that instructions will not be issued at my Location for their removal until this RISSP is cancelled.

Signed (Implementing Safety Co-ordinator)

at (time) on (date)

PART 2

2.1 CANCELLATION

I have receive d confirmation from _____ (name of the Requesting Safety Co-ordinator) at _____ (Location) that the Safety Precautions set out in paragraph 1.2 are no longer required and accordingly the RISSP is cancelled.

Signed (Implementing Safety Co-ordinator)

at (time) on (date)

(Note: This form to be of a different colour from RISSP-R.)

Version 2.0

RI SSP Examples: OC8B

OC8B - APPENDIX A

RECORD OF INTER-SYSTEM SAFETY PRECAUTIONS (RISSP-R) (Requesting Safety Co-ordinator's Record)

RISSP NUMBER _____

1.1 CIRCUIT IDENTIFICATION

Safety Precautions have been established by the Implementing Safety Co-ordinator to achieve Safety From The System on the following HV Apparatus:

The RI SSP number as quoted by the Requesting Safety Co-Ordinator

Identification of the HV Apparatus to be worked on and circuits up to the connection point, agreed by both Safety Co-ordinators

1.2 SAFETY PRECAUTIONS ESTABLISHED

(a) ISOLATION

State the Locations(s) at which Isolation has been established on the Implementing Safety Co-ordinator's System. For each Location, identify each point of Isolation. For each point of Isolation state, the means by which the Isolation has been achieved, and whether, immobilised and Locked, Caution Notice affixed, other Safety Precautions applied, as appropriate.

Details of apparatus that in the opinion of the Implementing Safety Co-ordinator should be included in the Safety Precautions taken and reported to the requesting Safety Co-ordinator

Version 2.0

56

The details of the form need to be discussed Briefly.
How to fill it in follows later.
Hand out blank copies of RISSP I & Rs.

RISSP Examples: OC8B

Details of Earths applied and confirmed as above

The Implementing Safety Co-ordinator states the earths applied for the Requesting Safety Co-ordinator's benefit

(b) EARTHING

State the Location(s) at which Earthing has been established on the Implementing Safety Co-ordinator's System. For each Location, identify each point of Earthing. For each point of Earthing state, the means by which the Earthing has been achieved, and whether, immobilised and Locked, other Safety Precautions applied, as appropriate.

1.3 ISSUE

I confirm d to _____ (name of Requesting Safety Co-ordinator) at _____ (Location) that the Safety Precautions identified in paragraph 1.2 have been established and that instructions will not be issued at my Location for their removal until this RISSP is cancelled.

Signed (Implementing Safety Co-ordinator)

at (time) on (date)

PART 2

2.1 CANCELLATION

I have receive d confirmation from _____ (name of the Requesting Safety Co-ordinator) at _____ (Location) that the Safety Precautions set out in paragraph 1.2 are no longer required and accordingly the RISSP is cancelled.

Signed (Implementing Safety Co-ordinator)

at (time) on (date)

(Note: This form to be of a different colour from RISSP-R.)

(b) EARTHING

State the Locations(s) at which Earthing has been established on the Implementing Safety Co-ordinator's System. For each Location, identify each point of Earthing. For each point of Earthing state, the means by which the Earthing has been achieved, and whether, immobilised and Locked, other Safety Precautions applied, as appropriate.

RI SSP Examples: OC8B

Both Requesting and Implementing Safety Co-ordinators shall complete and sign part 1.3 of the RI SSP-R and RI SSP-I forms respectively
Once signed no alterations are permitted
The RI SSP can only be cancelled

When safety precautions are no longer required, (i.e. all work complete and any Safety documents Cancelled), the Requesting Safety Co-ordinator will contact the Implementing Safety Co-ordinator to effect cancellation of the RI SSP

1.3

ISSUE

I have received confirmation from _____ (name of Implementing Safety Co-ordinator) at _____ (Location) that the Safety Precautions identified in paragraph 1.2 have been established and that instructions will not be issued at his Location for their removal until this RI SSP is cancelled.

Signed (Requesting Safety Co-ordinator)
at (time) on (date)

PART 2

2.1

CANCELLATION

I have confirmed to _____ (name of the Implementing Safety Co-ordinator) at _____ (Location) that the Safety Precautions set out in paragraph 1.2 are no longer required and accordingly the RI SSP is cancelled.

Signed (Requesting Safety Co-ordinator)
at (time) on (date)

Case Studies

Make case studies site specific

Case Study 1

You are the Safety Co-ordinator and the TL require to work on Main Busbar 2

Generators 1 & 2 and their associated switches are owned by your company up to the busbar connections

Discuss the procedure, the precautions required and describe

Version 2.0

59

Copies of a sub station diagram are issued to the class for a practical study of the RISSP procedure. Role play may be used to give the delegates practice in using the RISSP forms,

Case Studies

Case Study 2

You are the Safety Co-ordinator and you require to work on X496

Generators 3 & 4 and their associated switches are owned by another company up to the busbar connections

Discuss the procedure, the precautions required and describe

Learning Points

When Things go wrong !!

The following slides show details of actual near misses involving Safety Co-ordination across the Control Boundaries

Version 2.0

61

The following slides run through some case studies and are useful to emphasise how easy it is to drift from the correct approach.

Learning Points

Control Interfaces

- In the past evidence suggests that the management of safety across control boundaries is problematic
- Past incident reports have emphasised this point
- Communication problems seem to be evident
- Lack of commonality between companies seems to be an issue

Version 2.0

62

The speaker must drive home the point that things do go wrong and go through the reasons.

Learning Points

400kv Substation Near Miss 1

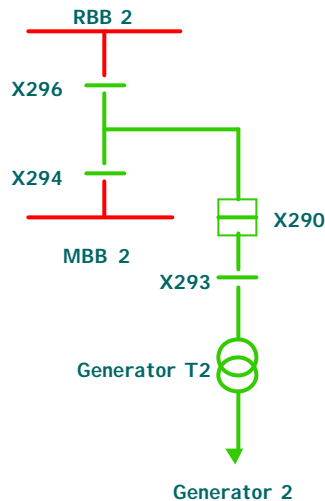

— TL Controlled
— GEN Controlled

- All equipment subject to TL safety rules
- Work to be carried out by TL on Power Station controlled isolator X296
- RI SSP requested by Power Station to hold precautions on Reserve Busbar 2
- RI SSP cancelled prematurely with Power Station safety documents still in place

Version 2.0

63

Discuss the details of the incident and cover the mistakes.

The Power Station were enacting the role of Requesting Safety Co-ordinator and should not have cancelled the RI SSP with a document still in force.

Whoever cancelled the RI SSP, and this would have been the Requesting Safety Co-ordinator, was unaware of the document in force and this would indicate a lack of control of the system falling under their responsibility.

Learning Points

400kv Substation Near Miss 1

The Generator Safety Co-ordinator was at fault.

Before cancelling the RI SSP, acknowledgement of the completion of the work on X296 should have been confirmed

Version 2.0

64

As Previous

Learning Points

400kv Substation Near Miss 2

— TL Controlled
— GEN Controlled

- Work required on X196 and X190 under TL Safety Rules
- Three TL requesting RISSPs cancelled because of either inadequate isolation or description of isolation
- Fourth RISSP correct
- Implementing TL RISSP cancelled and re-issued due to earthing requirements.
- Whole process took close to four hours

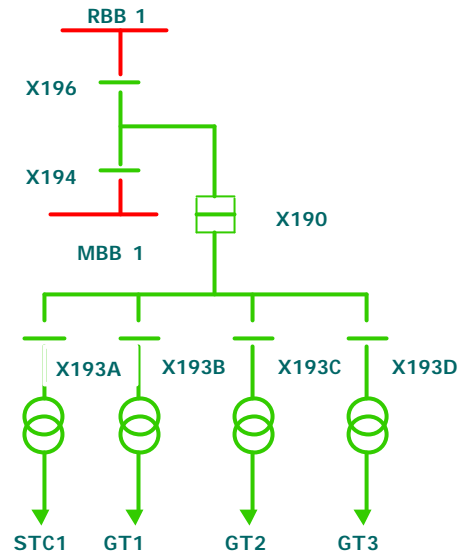

Version 2.0

65

Discuss

Learning Points

400kv Substation Near Miss 2

On this occasion both Safety Co-ordinators demonstrated inadequacies in their approach

The preamble should have clarified the extent of the work and what actions were required to provide the necessary safety precautions

The trial and error approach, until the correct RI SSP is achieved, is unacceptable

Version 2.0

66

Discuss

Learning Points

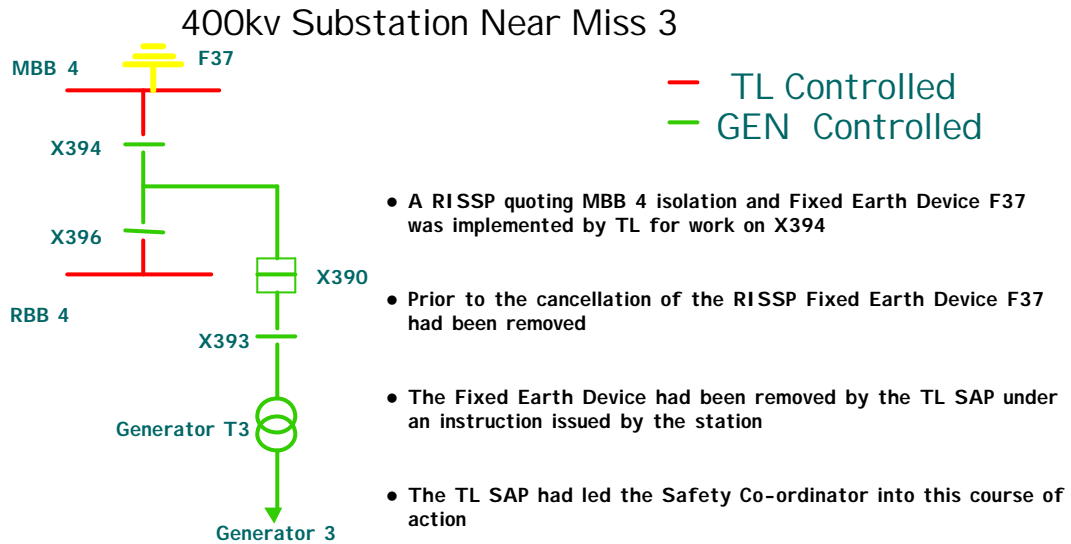

Version 2.0

67

Discuss

Learning Points

400kv Substation Near Miss 3

This example clearly demonstrates what should not happen

The Safety Co-ordinator should be the key decision maker under these circumstances, and have a full understanding of the procedures and protocol

The SAP should not be taking the lead and directing the actions of the Safety Co-ordinator

Pause to fully understand issues before proceeding

Version 2.0

68

Discuss

End of Course Questionnaire

Version 2.0

69

Safety Co-ordinator Training

END

Version 2.0

70

Final summing up and questions