

# Gas Industry Standard

GIS/GQ7:2006

---

---

Specification for

**Equipment for odour intensity monitoring**

---

---

nationalgrid

Northern  
Gas Networks 

 **Scotia**  
Gas Networks plc

 **WALES&WEST**  
UTILITIES



---

## Contents

	Page
Foreword	iii
Mandatory and non-mandatory requirements	iii
Disclaimer	iii
Brief history	iv
Introduction	1
1 Scope	1
2 Normative references	1
3 Specification for natural gas standards for odour intensity calibration	1
4 Specification for local olfactory calibration facility	2
4.1 Introduction	2
4.2 Number and location	2
4.3 Calibration facility	2
5 Specification for primary olfactory calibration facility	3
5.1 Odour chamber	3
5.2 Sample injection chamber	3
5.3 Odorant vaporizer	3
5.4 Other sample injection chamber equipment	4
5.5 Chemicals	4
5.6 Laboratory facilities	4
5.7 Facilities for rhinologists	4
6 Specification for odorimeter	5
6.1 Introduction	5
6.2 Functional specification	5
Figure 1 — Line diagram of LOCF blending panel	3
Figure 2 — Odour chamber for primary olfactory calibration facility	5
Figure 3 — Sketch of the odorimeter	6



## Foreword

Gas Industry Standards (GIS) are revised, when necessary, by the issue of new editions. Users should ensure that they are in possession of the latest edition. Contractors and other users external to Gas Transporters should direct their requests for copies of a GIS to the department or group responsible for the initial issue of their contract documentation.

Comments and queries regarding the technical content of this document should be directed in the first instance to the contract department of the Gas Transporter responsible for the initial issue of their contract documentation.

This standard calls for the use of procedures that may be injurious to health if adequate precautions are not taken. It refers only to technical suitability and does not absolve the user from legal obligations relating to health and safety at any stage.

Compliance with this engineering document does not confer immunity from prosecution for breach of statutory or other legal obligations.

## Mandatory and non-mandatory requirements

For the purposes of a GIS the following auxiliary verbs have the meanings indicated:

- can** indicates a physical possibility;
- may** indicates an option that is not mandatory;
- shall** indicates a GIS requirement;
- should** indicates best practice and is the preferred option. If an alternative method is used then a suitable and sufficient risk assessment needs to be completed to show that the alternative method delivers the same, or better, level of protection.

## Disclaimer

This engineering document is provided for use by Gas Transporters and such of their contractors as are obliged by the terms of their contracts to comply with this engineering document. Where this engineering document is used by any other party, it is the responsibility of that party to ensure that the engineering document is correctly applied.

## Brief history

First Published as T/SP/GQ/7 Editorial update to comply with GRM Edited by BSI in accordance with BS 0-3:1997	May 2004 August 2004 August 2006
---	--

© **National Grid**, on behalf of National Grid, Northern Gas Networks, Scotia Gas Networks, and Wales and West Utilities.

This Gas Industry Standard is copyright and must not be reproduced in whole or in part by any means without the approval in writing of either National Grid, Northern Gas Networks, Scotia Gas Networks, or Wales and West Utilities.

## Introduction

In order to ensure public safety and to ensure conformance to the Gas Safety (Management) Regulations 1996, the *Gas Requirements Manual* requires that odorant is added to gas in specified networks to ensure that gas has a distinctive and characteristic smell that is readily detectable by the gas user and the public in the event of an escape of gas. T/MP/GQ2 contains requirements for odorization and odour intensity monitoring and T/WP/GQ6 provides work procedures for odour intensity monitoring.

### 1 Scope

This Gas Industry Standard provides details of equipment and materials needed to conform to the requirements of the *Gas Requirements Manual*.

### 2 Normative references

The following referenced documents are indispensable for the application of this document. For dated references, only the edition cited applies. For undated references, the latest edition of the referenced document (including any amendments) applies.

#### National Grid standards

*Gas Requirements Manual*.

T/MP/GQ2, *Management procedure for odorisation, odour intensity monitoring and control*.

T/WP/GQ6, *Work procedures for odour intensity monitoring*.

T/PR/INQ1, *Procedures for recalibration and checking of gascoseeker portable gas detectors*.

T/PR/INQ5, *Procedures for calibration and checking of gascoseeker Mk2 portable gas detectors*.

T/PR/INQ6, *Procedures for maintaining the integrity of portable instruments and test equipment*.

### 3 Specification for natural gas standards for odour intensity calibration

#### 3.1 Working calibration standards

Working calibration standards containing odorized natural gas, obtained from an accredited supplier, shall be used for the calibration of primary olfactory calibration facility (POCF) service provider rhinologists. The POCF service provider shall monitor the stability of this standard throughout its lifetime.

#### 3.2 Field calibration standards

**3.2.1** Field calibration standards containing odorized natural gas shall be used for the self-assessment and calibration of rhinologists. The POCF service provider shall monitor the stability of this standard for the first 6 months from the time of filling prior to issue for use. Thereafter, the standard will be valid for 1 year, after which it shall be replaced.

**3.2.2** The cylinders containing the field calibration standards shall be filled in accordance with T/WP/GQ6. Field standards appropriate for LPG for use by Scottish Independent Undertakings shall be purchased from the gas transporter's specialist gas standards supplier.

## **4 Specification for local olfactory calibration facility**

### **4.1 Introduction**

The local olfactory calibration facility (LOCF) is used to present natural gas-air mixtures of known odour intensity to rhinologists. The LOCF is employed for calibration (under the supervision of a network lead rhinologist) or for self-assessment by a rhinologist. It consists of cylinder supplies of odorized natural gas and breathing quality air, piped to a blending panel that delivers a natural gas-air mixture to a one-man odorimeter for presentation to rhinologists.

### **4.2 Number and location**

The number of LOCFs and their location shall be planned so as to optimize the travelling distances for rhinologists, the installation and running costs of the LOCFs and the number of rhinologists using each LOCF.

### **4.3 Calibration facility**

**4.3.1** The blending panel and one-man odorimeter shall be situated indoors in a clean, well-ventilated and safe site with no hazardous or odoriferous activities in the vicinity. The blending panel may be wall mounted (with sufficient clearance to accommodate the rear fittings) against an outside wall. A desk or table adjacent to the blending panel shall be provided for the one-man odorimeter and results log. The gas and air cylinders shall be situated outside at a facility where two air and two natural gas cylinders can be safely stored. Typically this may be against the wall (through which the gas and air may be piped) and close to the position of the blending panel equipment.

**4.3.2** Figure 1 shows a simplified line diagram of the blending panel.

Pipework for the blending facility to the one-man odorimeter shall be constructed using silicone or stainless steel tubing. Pipework from cylinders to the blending facility shall be in stainless steel. Any stainless steel tubing which will be wetted with odorized natural gas shall be conditioned prior to first use by flowing overnight with odorized natural gas.

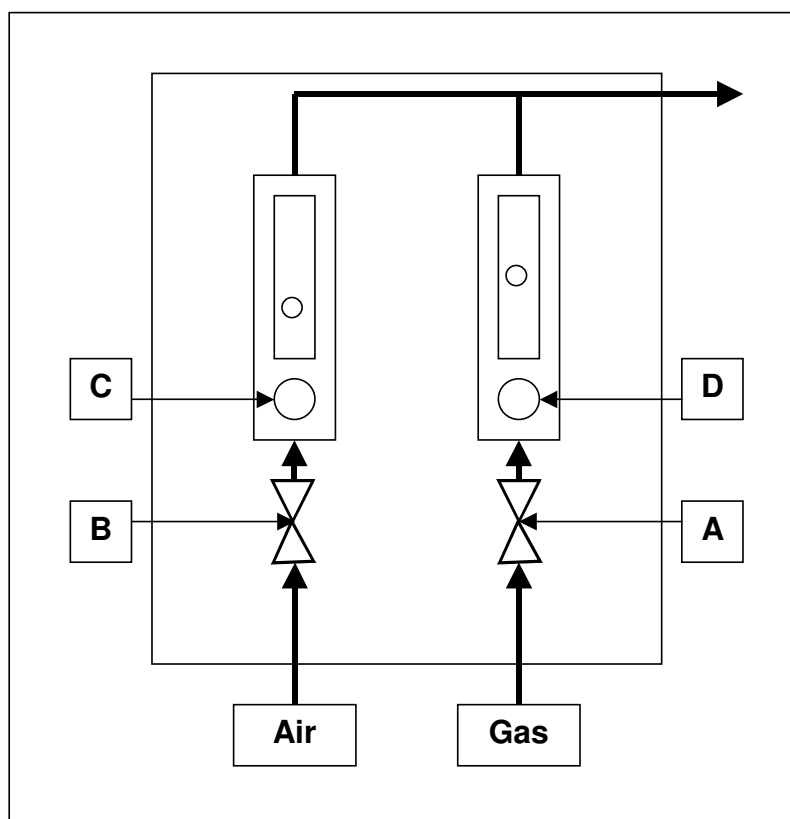

Figure 1 — Line diagram of LOCF blending panel

## 5 Specification for primary olfactory calibration facility

### 5.1 Odour chamber

A suitable design is shown in Figure 2. It consists of a room, A, of internal dimensions 2.45 m high by 2.13 m wide by 3.35 m long, i.e. of capacity 17.5 m<sup>3</sup>, separated by a close-fitting door from an airlock, B, of the same height and width, but 1.3 m long. The room, airlock and doors are lined with aluminium sheet. There are four mixing fans, C, in the room, a closable outlet in the ceiling to an extractor fan that safely vents, via a carbon filter, outside the building, a window in the side and lighting through a glass panel in the ceiling. A carbon air filter is fitted in the side of the airlock to purify the air drawn in by the extractor fan.

### 5.2 Sample injection chamber

Adjoining the odour chamber is a sample injection chamber, E, from which the odorant is added via the injection points, G. This chamber is fitted with a separate extractor fan.

### 5.3 Odorant vaporizer

A suitable device consists of a glass tube fitted with a short side arm into which a rubber septum is inserted. An electromantal cord heater is used to obtain an internal temperature of approximately 100 °C. The whole unit is insulated electrically and thermally.

#### **5.4 Other sample injection chamber equipment**

The following equipment is also required:

- a) flow tube;
- b) digital thermometer with probe (suitable for use up to 110 °C);
- c) timer;
- d) clamp stand, arm and boss head;
- e) burette clamp;
- f) syringes, 1 µl, 5 µl, 10 µl, 25 µl and 100 µl;
- g) sample vials with screw caps;
- h) Pasteur pipettes;
- i) vial septa to fit Pasteur pipettes;
- j) volumetric flask, 5 ml;
- k) pipette, 0 ml – 0.5 ml, graduated 0.1 ml;
- l) pipette filler;
- m) assorted beakers;
- n) septa.

#### **5.5 Chemicals**

The following reagents are required:

- a) new blend, NB, odorant [an 80:20 mixture of tert-butyl mercaptan (TBM) and dimethyl sulfide (DMS)];
- b) methanol;
- c) bleach;
- d) nitrogen;

#### **5.6 Laboratory facilities**

The following facilities are required:

- a) a carbon-filtered fume cupboard for preparation of odorant mixtures and odorant handling;
- b) an area for calibration of one-man odorimeters;
- c) an odorized gas supply for the calibration of one-man odorimeters;
- d) a personal computer for data collection and production of certificates.

#### **5.7 Facilities for rhinologists**

The following facilities are required:

- a) a ventilated room free from any distinctive odours for resting between chamber tests;
- b) a room for theoretical training (can be the same room as above);
- c) toilets.

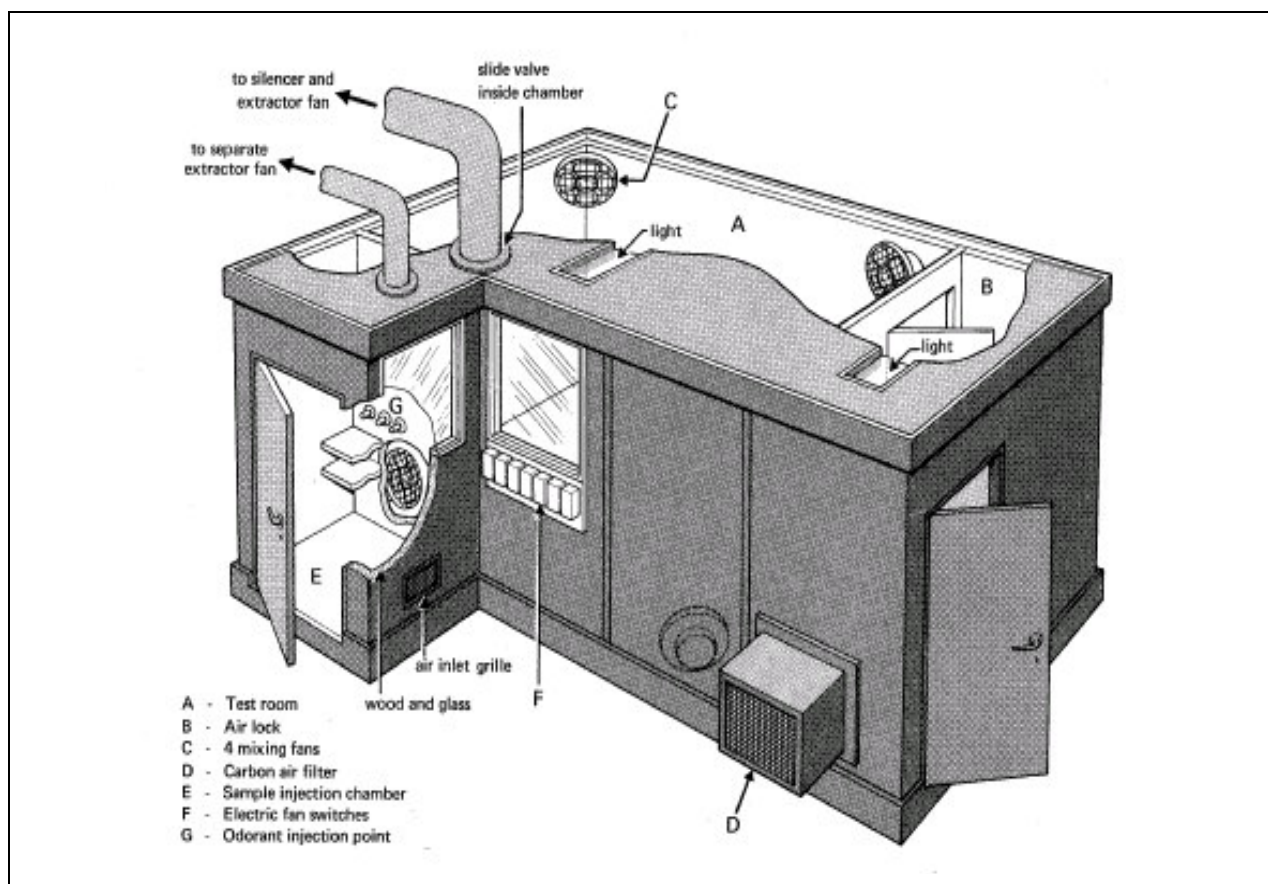

Figure 2 — Odour chamber for primary olfactory calibration facility

## 6 Specification for odorimeter

### 6.1 Introduction

The odorimeter is of custom design. A sketch of a typical unit is shown in Figure 3.

### 6.2 Functional specification

The overall construction shall be in stainless steel, with the exception of the funnel which is powder-coated to minimize extraneous odours. The odorimeter shall contain a battery-controlled fan capable of delivering a constant air flow of  $25 \text{ dm}^3/\text{min}$  and a suitable needle valve for adjustment of gas:air ratio by controlling the flow of gas. A suitable indication of battery condition shall be provided.

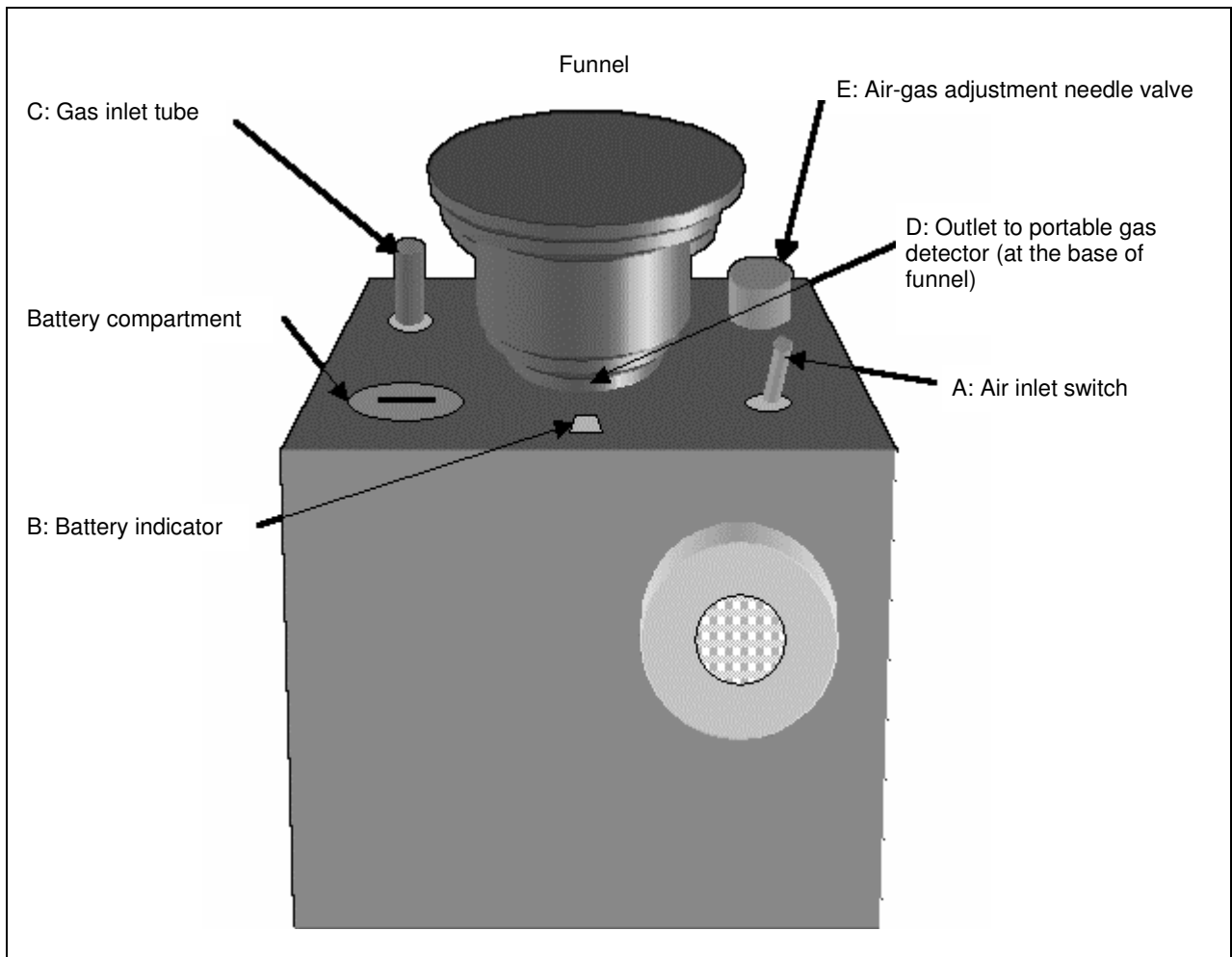

**Figure 3 — Sketch of the odorimeter**