

National Grid UK Electricity Transmission plc

Uncontrolled when printed

NATIONAL SAFETY INSTRUCTION

Guidance Notes

NSI 11

HIGH VOLTAGE CAPACITOR BANKS

Copyright National Grid plc 2008 ©, all rights reserved. No part of this publication may be reproduced, stored in a retrieval system, or transmitted in any form or by any means electronic, mechanical, photocopying, recording or otherwise, without the written permission of National Grid obtained from the issuing location.

The contents of National Grid documents are based on the needs of National Grid and the conditions under which it operates. It shall not therefore be assumed that the contents stated therein necessarily meet the particular circumstances and requirements of other organisations. The principles set out in this document are for information only and therefore National Grid is not liable to any third party for any loss or damage resulting from reliance on the contents. It is the responsibility of such external organisations to check that the document is the latest version and is appropriate for their purposes.

DOCUMENT HISTORY

Issue	Date	Summary of Changes / Reason	Author(s)	Approved By (Title)
1	Sept. 08	Reformatted and re-drafted to follow 3 rd edition Electricity Safety Rules layout. Safety bulletin 147, incorporated.	NSI Working Group	MDE Manager Les Adams 

KEY CHANGES

Section	Amendments

HIGH VOLTAGE CAPACITOR BANKS

CONTENTS

	Page
1 Purpose and Scope	1
2 Definitions	1
3 Dangers	2
4 General Requirements for Work	3
5 Performing Capacitance Measurements	7
6 Handling, Storage and Transport of Capacitor Units	8
Appendix	
A Authorisation Matrix for Contractors Personnel	12

1 Purpose and Scope

To provide guidance on National Safety Instruction 11, when applying principles established by the Safety Rules to achieve **Safety from the System** for personnel, working on **High Voltage** Capacitor Banks including the removal of **Charged** energy.

National Safety Instruction 11 applies to Capacitor Banks that may or may not be fitted with a *Shorting Switch*. *Shorting Switch(es)* are not fitted to new Static Capacitor Banks (and in some cases have been removed from existing Static Capacitor Banks) since they provide no additional safety function to that already provided by the **Primary Earth** switch, discharge VT and the *Capacitor Unit* discharge resistors. Most importantly, *Shorting Switch(es)* do not dissipate the **Charged** energy stored in externally fused capacitors, where the external fuse has operated. No additional safety measures are therefore required beyond those described in this document when performing work on Static Capacitor Banks not fitted with *Shorting Switch(es)*.

National Grid **Personnel** working on **High Voltage** Capacitor Banks shall be appointed to this NSI. For Contractor appointment see appendix A.

The layout of this guidance note reflects that of legislative codes of practice, where the rule (or mandatory obligation) is identified by a green panel on the left-hand side. The guidance follows after the rule and is identified by a blue panel.

Within National Grid the guidance notes hold equivalent status of an Approved Code of Practice (ACOP) in law. If not followed, you will be required to demonstrate that your safe system of work is of an equal or higher standard.

2 Definitions

Terms printed in bold type are as defined in the Safety Rules.

Title	Definition
<i>Capacitor Unit</i>	An assembly of one or more capacitor elements in the same container with terminals brought out by one or more bushings
<i>Capacitor Rack</i>	An individual framework containing <i>Capacitor Unit(s)</i> connected together
<i>Capacitor Stack</i>	An assembly of <i>Capacitor Rack(s)</i> connected together. If the Equipment consists of only one <i>Capacitor Rack</i> the term <i>Capacitor Stack</i> will also apply. A <i>Capacitor Stack</i> may contain <i>Capacitor Unit(s)</i> from one or more discrete components of the Static Capacitor Bank, e.g. the main and auxiliary capacitors, resistors and air cooled reactors
<i>Capacitor Bank</i>	An assembly of one or more <i>Capacitor Stack(s)</i> forming the Static Capacitor installation
<i>Discharge Stick</i>	A type registered device for the purpose of discharging a <i>Capacitor Unit</i> which may be Charged
<i>Shorting Switch</i>	A fixed device for short-circuiting to earth <i>Capacitor Unit(s)</i> in <i>Capacitor Rack(s)</i>
<i>Short-Circuiting Lead</i>	A type registered lead used for short-circuiting an individual <i>Capacitor Unit</i> . This can be a clip-on short used during the disconnection of <i>Capacitor Unit</i> or a bolt-on short used during the removal.
<i>Technical Specialist</i>	Any individual from the Technical Support group within the Company with detailed specialist technical knowledge to assist when required in the safe installation, preparation for work, maintenance and removal of <i>Capacitor Unit(s)</i> .

3 Dangers

The **System Danger(s)** to personnel are electric shock, burns and effects on eyes arising from:-

- The discharge of electrical energy retained by the *Capacitor Unit(s)* after they have been **Isolated**
- Inadequate precautions to guard against electric shock as a result of any **Charged** conductors or associated fittings
- **Charged** capacitors inadequately short circuited
- **Equipment** retaining or re-gaining a charge

NSI 11
4.1 to 4.7

4 General Requirements for Work

- 4.1 The *Capacitor Bank* shall be **Isolated**, **Point(s) of Isolation** established and **Primary Earth(s)** applied.
- 4.2 *Shorting Switch(es)*, where installed on the *Capacitor Rack(s)*, shall be closed by a **Senior Authorised Person** under the instruction of a **Control Person (Safety)**.
- 4.3 A **Permit for Work** or **Sanction for Work** shall be issued.
- 4.4 Where work is to be performed on any *Capacitor Rack* then an **Earthing Schedule** shall be issued by the **Senior Authorised Person** stating:-
- **Drain Earth** shall be applied to the connection point between any *Capacitor Bank* and any reactor
 - Location and the application of discharge stick, and any shorting leads
- Drain Earth(s)** shall be applied by a **Competent Person**, or by a **Person** under the **Personal Supervision** of a **Competent Person**.
- 4.5 Before approaching any externally fused *Capacitor Bank*, *Capacitor Unit(s)* with fuses that have operated shall be identified.
- 4.6 Before performing any work on a *Capacitor Bank* the following shall be undertaken:-
- *Capacitor Unit(s)* shall be visually, inspected at a distance greater than the length of the *Discharge Stick* from exposed capacitor bushing or blown fuse, in order to identify any abnormal *Capacitor Unit(s)*.
 - *Capacitor Unit* or *Capacitor Unit(s)* in a parallel group shall be discharged using a *Discharge Stick* operated by a **Competent Person**, or by a **Person** under the **Personal Supervision** of a **Competent Person**.
- At no time whilst, connecting the clip-on or crook end of a *Discharge Stick* shall any part of the body encroach within a distance shorter than the length of the *Discharge Stick* from exposed capacitor bushing or blown fuse. The *Discharge Stick* shall be applied at arms length.
- 4.7 *Discharge Stick* and *Short-Circuiting Lead(s)* shall be inspected and maintained.

Guidance
NSI 11
4.2

4 General Requirements for Work

- 4.2 *Shorting Switch(es)* are not normally remotely controlled and as such they shall be operated locally under the instruction of a local **Control Person (Safety)** 1, as defined in Management Procedure NSI 30 Authorisation of Personnel.

The **Senior Authorised Person** shall act as an **Authorised Person** to close the *Shorting Switch(es)* prior to the issue of the **Safety Document**. The *Shorting Switch(es)* closed shall be stated on the **Safety Document** and shall form the record of the safety precautions established. This shall be identified in Section 2 of the **Safety Document** "Actions taken to avoid Danger".

Guidance
NSI 11
4.3 to 4.4

- 4.3 **SAFETY WARNING** - The **Senior Authorised Person** issuing the **Safety Document** shall ensure the time difference between the completion of the isolation of the *Capacitor Bank* (as recorded on the Switching Instruction) and the time of issue of the **Safety Document** to the **Competent Person** shall be a minimum of 20 minutes. This is to allow sufficient time for the *Capacitor Bank* to discharge via the *Capacitor Unit* discharge resistors.
- 4.4 The **Drain Earth** is used to prevent a potentially **High Voltage** being generated by the 50 Hz resonant circuit formed by capacitor C2 and reactor L1 whilst performing capacitor measurements, refer to Figure 4.4A. To apply / remove the **Drain Earth** the **Competent Person** receiving the **Safety Document** shall be authorised to Management Procedure NSI 2 "Earthing High Voltage Equipment" section 5.1.

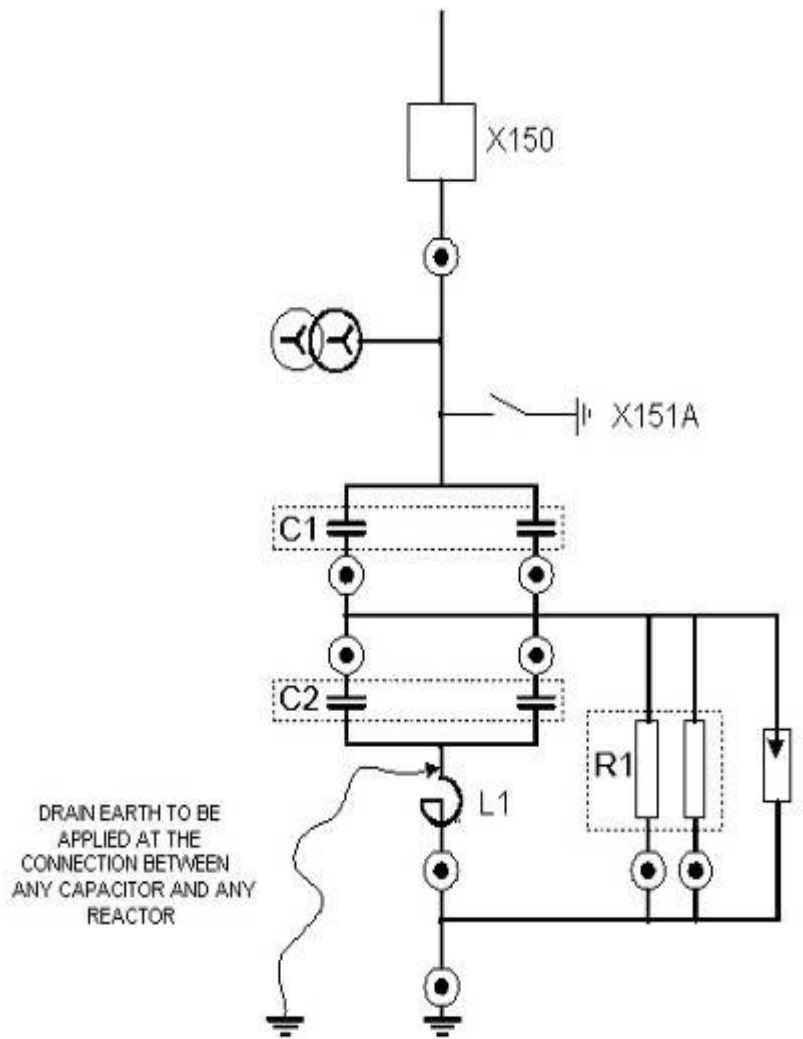

SINGLE LINE DIAGRAM OF A TYPICAL MECHANICALLY SWITCHED CAPACITOR WITH DAMPING NETWORK (MSCDN)

Figure 4.4A - Location of the Drain Earth Between any Capacitor Bank and any Reactor.

Guidance
NSI 11
4.5

4.5 Operated externally fused *Capacitor Unit(s)* can be identified by their fuse tails hanging down, refer to Figure 4.5A.



Figure 4.5A - Identifying an Externally Fused Capacitor with a Fuse Operated

SAFETY WARNING - Any externally fused *Capacitor Unit(s)* with fuses that have operated shall be assumed to be **Charged** and dangerous. These *Capacitor Unit(s)* shall be discharged using a *Discharge Stick* by a **Competent Person**, or by a **Person** under the **Personal Supervision** of a **Competent Person**. Refer to guidance section 4.6.

Guidance
NSI 11
4.6

- 4.6 A *Discharge Stick* shall be used on all *Capacitor Unit(s)* to dissipate any potentially **Charged Capacitor Unit(s)**.

Capacitor Unit(s) by design, dissipate stored voltage via a discharge resistor to a value of approximately 75 V in around 10 minutes (20 minutes for a *Capacitor Bank*). However, in certain conditions e.g. fuse and discharge resistor failure, there is a potential for the capacitor unit voltage to remain at a value up to approximately 20 kV, dependant on capacitor bank type and rating. The closure of *Shorting Switch(es)*, if fitted, in this instance does not discharge the faulty *Capacitor Unit*. Hence the requirement to use a *Discharge Stick* on all *Capacitor Unit(s)*.

The *Discharge Stick* shall be used by first connecting the clip-on end of the *Discharge Stick* to the low voltage terminal of the *Capacitor Unit* and applying the “crook” end of the *Discharge Stick* to the capacitor bushing, refer to Figure 4.6A & 4.6B. If the *Capacitor Unit* has two bushings, then a second *Discharge Stick* is required for the second bushing. The *Discharge Stick(s)* shall be used by first connecting the clip-on end of the *Discharge Stick(s)* to the rack metalwork and applying the “crook” end of the first *Discharge Stick* to the first capacitor bushing and the “crook” end of the second *Discharge Stick* to the second capacitor bushing.

With reference to Figure 4.6A, at no time whilst connecting the clip-on or crook end of a *Discharge Stick* shall any part of the body encroach to within a distance shorter than the length of the *Discharge Stick* to the exposed capacitor bushing. The *Discharge Stick* shall be applied at arms length.

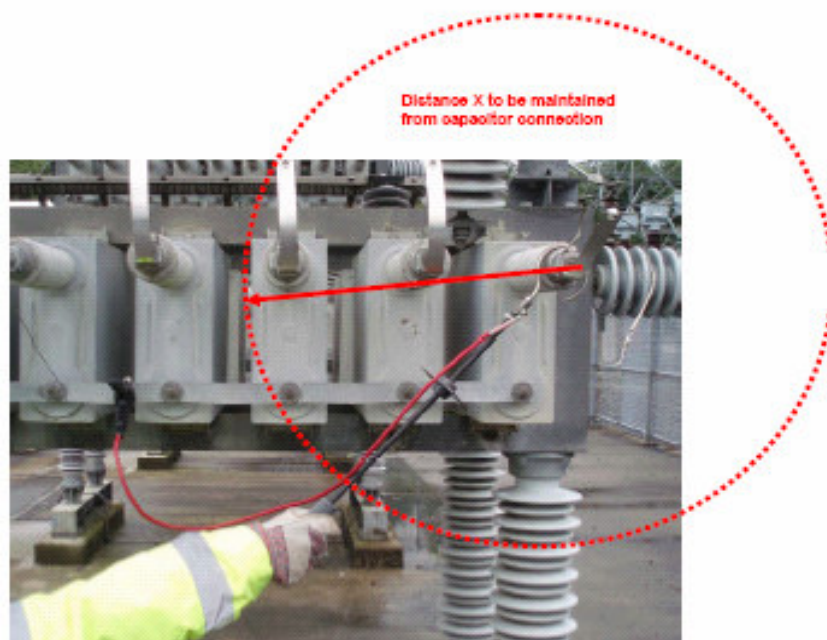

Figure 4.6A - Applying the *Discharge Stick* to a *Capacitor Unit* Bushing

Guidance
NSI 11
4.6 Cont. to 4.7

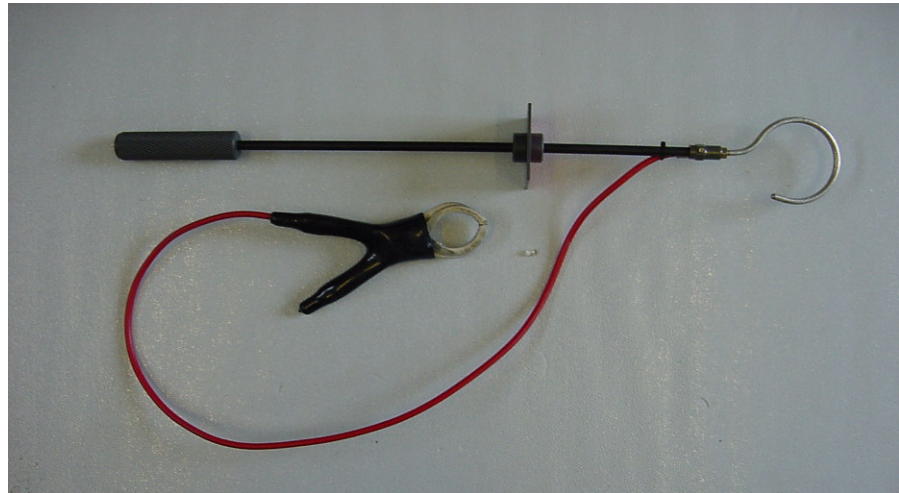

Figure 4.6B – Discharge Stick

Abnormal *Capacitor Unit(s)* are those that show signs of excessive bulging, major leaks or broken bushings. If any abnormal *Capacitor Unit(s)* are found, especially following a fault, then advice from a *Technical Specialist* shall be sought.

- 4.7 *Discharge Stick(s)* and *Short Circuiting Lead(s)* shall be visually inspected for damage before and after use. Maintenance shall be carried out in accordance with Management of Maintenance Policy NSPM203.

NSI 11
5.1

5 Performing Capacitance Measurements

- 5.1 Before and after performing capacitance measurements, the *Capacitor Unit* or *Capacitor Unit(s)* in a parallel group shall be discharged using a *Discharge Stick* by a **Competent Person**, or by a **Person** under the **Personal Supervision** of a **Competent Person**.

Guidance
NSI 11
5.1

5 Performing Capacitance Measurements

- 5.1 Refer to guidance Section 4.6 for discharging *Capacitor Unit(s)* using a *Discharge Stick*.

Connect the capacitance bridge to a series group of *Capacitor Unit(s)* starting at the low voltage end of the *Capacitor Stack*.

Perform capacitance measurements as required on *Capacitor Unit(s)* in that series group.

Continue capacitor measurements working on the next series group of *Capacitor Unit(s)* towards the high voltage end of the *Capacitor Stack*.

In exceptional circumstances an individual may be used for technical expertise e.g. third party SVC technical specialists. A **Competent Person** shall provide **Personal Supervision** to the individual.

NSI 11
6.1 to 6.5

6 Handling, Storage and Transport of Capacitor Units

- 6.1 Where there is a potential for a *Capacitor Unit* to become **Charged** they shall not be handled unless it is short-circuited.
- 6.2 Before the application of a *Short-Circuiting Lead* to a *Capacitor Unit*, it shall be discharged using a *Discharge Stick* by a **Competent Person**, or a **Person** under the **Personal Supervision** of a **Competent Person**.
- 6.3 The positions for application of clip-on *Short-Circuiting Lead(s)* shall be specified on an **Earthing Schedule**.
- Short-Circuiting Lead(s)* shall be applied to the *Capacitor Unit(s)* to be worked on by a **Competent Person**, or by a **Person** under the **Personal Supervision** of a **Competent Person**.
- 6.4 Before a *Capacitor Unit* is removed from a *Capacitor Rack*, the clip-on *Short-Circuiting Lead* shall be immediately replaced by a bolt-on *Short-Circuiting Lead* or shorted by copper wire by a **Competent Person**, or by a **Person** under the **Personal Supervision** of a **Competent Person**.
- 6.5 Failed *Capacitor Unit(s)* when stored and transported shall remain short-circuited.

Guidance
NSI 11
6.1

6 Handling, Storage and Transport of Capacitor Units

- 6.1 SAFETY WARNING** – Where there is a potential for a *Capacitor Unit* to become **Charged** e.g. within an **HV** compound they shall not be handled unless it is short-circuited by a *Short-Circuiting Lead*, refer to Figure 6.1A & B.



Figure 6.1A – Clip-on *Short Circuiting Lead*



Figure 6.1B – Bolt-on *Short-Circuiting Lead*

Guidance
NSI 11
6.2 to 6.3

6.2 Refer to guidance Section 4.6 for discharging *Capacitor Unit(s)* using a *Discharge Stick*.

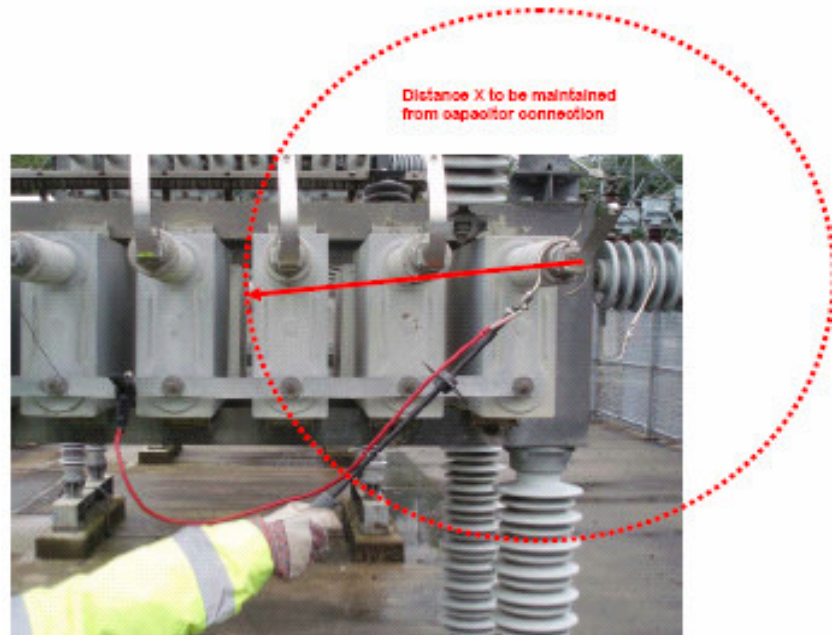

Figure 6.2A - Applying the *Discharge Stick* to a *Capacitor Unit* Bushing

6.3 The *Capacitor Unit* shall be short-circuited by connecting a clip-on *Short Circuiting Lead* between the capacitor low voltage terminal and bushings. If the capacitor unit has two bushings, a second *Short-Circuiting Lead* shall be connected between a bushing terminal and the *Capacitor Unit* metal case.



Figure 6.3A – Applying the Clip-on *Short Circuiting Lead*

Guidance
NSI 11
6.4 to 6.5

- 6.4 *Capacitor Unit(s)* shall be short-circuited using a *Short-Circuiting Lead* or at least two complete turns of copper wire of not less than 1.0 mm diameter.

Capacitor Unit(s) with one bushing and a case connected terminal shall have one short-circuit connection between those two terminals.

Capacitor Unit(s) with two bushings insulated from the case shall be short-circuited by two connections, one between the two bushing terminals and an additional connection between one of the bushing terminals and the metal case.

- 6.5 A failed *Capacitor Unit(s)* shall remain shorted due to the potential for the bushing to become **Charged**. This is due to the possibility of a trapped internal charge within the failed unit re-connecting to the bushing during movement.

Appendix A - Authorisation Matrix for Contractors Personnel

Contractor Personnel	Person	Competent Person	Authorised Person	Senior Authorised Person
Sections	N/A	N/A	N/A	N/A

Contractors Personnel

Contractors by law have a duty to provide a safe system of work for their employees.

National Grid have a duty in law to employ competent Contractors to undertake work on capacitor banks and provide them with relevant safety information to enable them to develop their own safe systems of work.

National Grid Supply Chain Management processes ensure competent Contractors are selected.

Once a competent Contractor is selected, National Grid has a duty to ensure the Contractor understands **Danger(s)** associated with undertaking work within a **HV** compound, permit systems, demarcation and safe access and egress, including movement of objects and vehicles etc. This is accomplished by Contractors employees being authorised to National Grid Safety Rules and to NSI 6 and 8, via Management Procedure - NSI 30 "Appointment of Persons".

The Contractor selected shall be an expert in the area of **HV Capacitor Bank(s)** and therefore there is no requirement for authorisation under NSI 11.

Before a **Safety Document** is issued the **Senior Authorised Person** shall be authorised to NSI 11 and shall ensure the Contractors risk assessment and method statements cover the **Danger(s)** identified in NSI 11.

The National Grid **Senior Authorised Person** will issue a **Safety Document** to a Contractors **Competent Person** authorised to NSI 6 & 8.

Note: If the work involves the application of **Drain Earth(s)** the Contractors **Competent Person** shall be authorised to Management Procedure - NSI 2 "Earthing High Voltage Equipment", or the **Senior Authorised Person** shall manage the **Drain Earth(s)** via the **Safety Document** transfer process.