

OBLIGATORY AND ENHANCED REACTIVE POWER SERVICES

Methodology Document for the Aggregation of Reactive Power Metering

March 2007

Network Operations
National Grid
National Grid House
Warwick Technology Park
Gallows Hill
Warwick
CV34 6DA

CONTENTS

	PAGE
1. Definitions and Interpretations	3
2. Introduction	3
3. Category A Methodology	4
4. Category B Methodology	6
5. Category C Methodology	9
6. Category D Methodology	12

1. DEFINITIONS AND INTERPRETATIONS

National Grid Electricity Transmission plc (“The Company”) is a member of the National Grid plc group of companies. National Grid is the trading name for National Grid plc.

In this document, except where the context otherwise requires, terms and expressions found in Schedule 3 to the Connection and Use of System Code (CUSC) have the same meanings, interpretations and constructions.

For the avoidance of doubt in this document, when considering the circuits that connect any source of Reactive Power to the GB Transmission System, the terms “leading reactive energy” and “lagging reactive energy” refer to “Mvarh import value” and “Mvarh export value” respectively, as defined in Appendix B of the Metering Codes of Practice 1 & 2¹ entitled “Labelling of Meters for Import and Export”. The Metering Codes of Practice can be found on the Elexon website at:

<http://www.elexon.co.uk/bscrelateddocs/codesofpractice/default.aspx>

2. INTRODUCTION

This document contains the metering aggregation methodologies for use in calculating the payments for the provision of either an Obligatory or Enhanced Reactive Power Service from any reactive power equipment including, for the avoidance of doubt, BM Units, Non-BM Units, Generating Units and other Plant and Apparatus or equipment.

The various meter aggregation methodologies set out in this document (as amended or supplemented from time to time) are designed to simulate, as far as reasonably practicable, the presence of a single meter at the Commercial Boundary in order to ascertain, in respect of reactive power equipment, the Mvarh import and Mvarh export values to be used in the calculation of payments to be made by The Company for reactive power produced by the reactive power equipment.

Where the reactive power equipment has a single meter located at or close to the Commercial Boundary, there is no requirement to apply any of the aggregation methodologies contained in this document and payments will be based on the actual recorded reading of the meter. In these cases, the provisions relating to meter aggregation in the relevant Ancillary Services Agreement will be designated “Not Applicable”.

¹Entitled on the web site as “The metering of circuits with a rated capacity exceeding 100 MVa for settlement purposes” (Metering Codes of Practice 1) & “The metering of circuits with a rated capacity exceeding 100 MVa for settlement purposes” (Metering Codes of Practice 2)

Reactive power equipment can comprise inter alia:-

- a) a single Generating Unit, Plant or Apparatus, with its own connection via a transformer to the Commercial Boundary with the GB Transmission System or the Distribution System of the host Public Distribution System Operator (PDSO)
- b) a BM Unit comprising several separate Generating Units. For example a combined cycle gas turbine module (CCGT Module) either directly connected or within an embedded power station
- c) a BM Unit comprising a single Generating Unit which shares a transformer or other connection to the Commercial Boundary with another Generating Unit
- d) one of the above but with more than one possible route of connection to the Commercial Boundary

As at March 2007, four distinct Metering System configurations in respect of reactive power equipment have been identified as necessary as specified in sub-paragraph 2.4 of Appendix 4 of Schedule 3 to the CUSC. This document sets out below the four methodologies (referred to in this document as "Categories A, B, C and D") which can be applied to these specific Metering System configurations.

3. CATEGORY A

This category covers the following cases:-

- (i) The reactive power equipment is metered by **one** set of Metering Equipment providing the Mvarh import and export values, which is located at the low voltage side of a generator step-up transformer.
- (ii) The reactive power equipment is metered by **one** set of Metering Equipment providing the Mvarh import and export values, which is located at the high voltage side of the generator step-up transformer, but physically remote from the Commercial Boundary.

The following two figures illustrate the two cases described above to which the Category A methodology described below can be applied. For illustrative purposes only, the reactive power equipment is a BM Unit represented as a single Generating Unit in figure (i) and several Generating Units within a CCGT Module in figure (ii), each with meters located at points marked "M".

Figure (i) Metering Equipment positioned at the low voltage side of the generator step-up transformer.

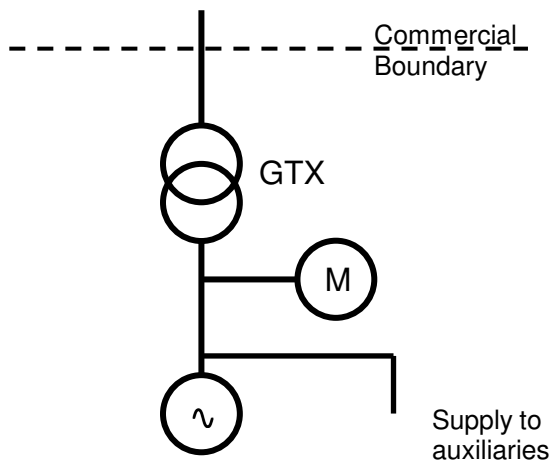
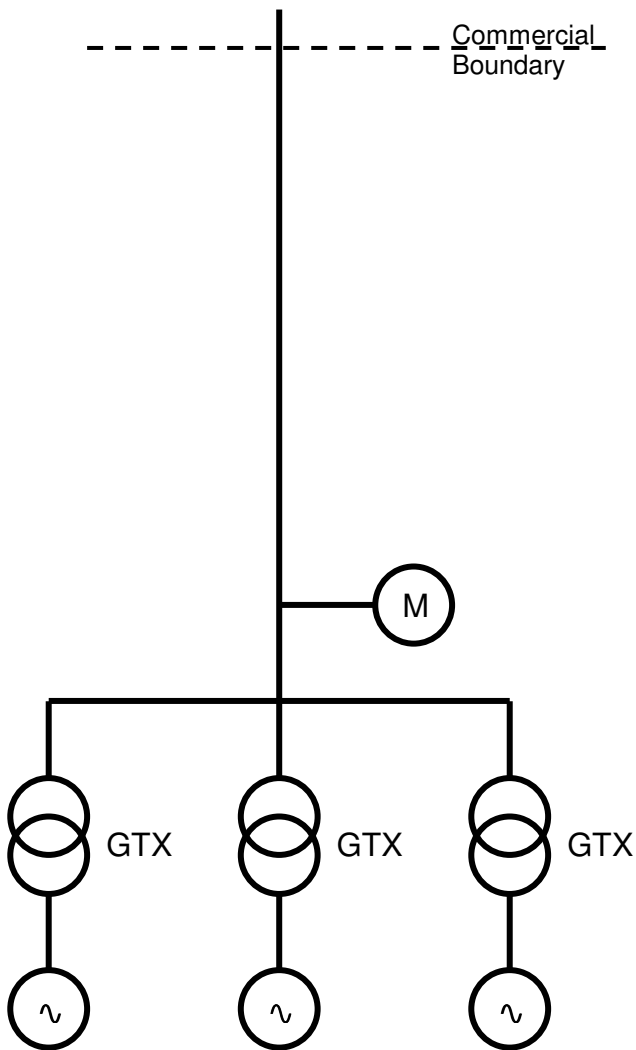

Figure (ii) Metering Equipment positioned at the high voltage side of the generator step-up transformer, but at a distance from the Commercial Boundary.



Methodology

No meter aggregation is required. However, in order to provide Mvarh import and Mvarh export values for the reactive power equipment at the Commercial Boundary, appropriate loss adjustment factors must be agreed between the User and The Company. In some cases, and subject to agreement, it may be possible to perform the adjustment within the Metering Equipment itself. If not, the governing principles for any Meter loss adjustment will be the same as those used in the LV to HV conversion formulae used for the calculation of Reactive Power capability at the Commercial Boundary as specified in the relevant Ancillary Services Agreement.

4. CATEGORY B

This category covers the case where the reactive power equipment has two or more Meters measuring Mvarh import and export values. This includes the following cases:

- The reactive power equipment is a BM Unit comprising a single CCGT Module or an embedded power station made up of several Generating Units, each with its own Meter located at the High Voltage side of the transformer.
- Where any one or more of the Meters is not positioned at or close to the Commercial Boundary then a method of Meter loss adjustment must first be agreed in accordance with the Category A methodology above. The adjusted Meter readings derived applying the Category A methodology will then be used in the aggregation methodology described below.

Figure (iii)

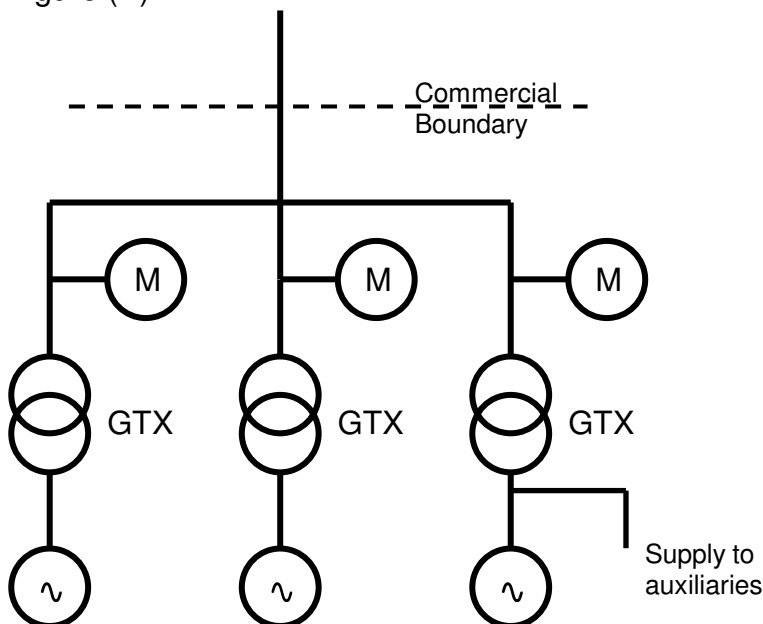

Methodology

In order to reflect possible Reactive Power imbalances across the metered points, two aggregation methodologies will apply, namely *linear addition* and *separation of totals*.

LINEAR ADDITION

Linear addition is the straight forward addition of the readings of the Mvarh leading and Mvarh lagging Meters at each metered point to give total Mvarh leading and Mvarh lagging reactive energy readings respectively. Linear addition is only applicable when all the meter values for a Settlement Period are in the same sense (i.e. providing all leading or all lagging reactive energy), or when both the leading and lagging meter values for the Settlement Period are reasonably balanced across all the metered points. Hence its application is limited to the following specific circumstances when, during a Settlement Period all Generating Units or embedded loads within the BM Unit are supplying in:-

- (a) always lagging (or zero) reactive energy; or
- (b) always leading (or zero) reactive energy; or
- (c) successive leading and lagging reactive energy or vice-versa, where both the leading and lagging values are each reasonably balanced.

SEPARATION OF TOTALS

In all other circumstances, separation of totals should be used to avoid the inclusion of Reactive Power which is circulating between individual Generating Units. By applying this aggregation methodology, the total of the metered leading reactive energy is subtracted from the total of the metered lagging reactive energy.

If the result is positive then the total is considered to be lagging reactive energy, and the lagging reactive energy for the BM Unit, (i.e. the CCGT Module or embedded power station), is equal to the numeric value of the result and leading reactive energy is deemed to be zero.

If the result is negative then the total is considered to be leading reactive energy, and the leading reactive energy for the BM Unit, (i.e. the CCGT Module or embedded power station), is equal to the numeric value of the result and lagging reactive energy is deemed to be zero.

The mathematical definitions of both the linear addition methodology and the separation of totals methodology are stated below, with the variables used in the mathematical definitions having the following definitions:-

n The total number of units

$lead_{total}$	The calculated leading reactive energy in a Settlement Period for a BM Unit, in Mvarh (a positive number or zero)
lag_{total}	The calculated lagging reactive energy in a Settlement Period for a BM Unit, in Mvarh (a positive number or zero)
$lead_i$	The metered leading reactive energy in a Settlement Period for the i th unit within a BM Unit, in Mvarh (a positive number or zero)
lag_i	The metered lagging reactive energy in a Settlement Period for the i th unit within a BM Unit, in Mvarh (a positive number or zero)
total	A variable defined in the equations below which can be positive, negative or zero.

Linear Addition

$$lead_{total} = \sum_{i=1}^n lead_i$$

$$lag_{total} = \sum_{i=1}^n lag_i$$

Separation of Totals

$$total = \sum_{i=1}^n lag_i - \sum_{i=1}^n lead_i$$

If total >0

then

$$\begin{aligned} lag_{total} &= total \\ lead_{total} &= 0 \end{aligned}$$

otherwise

$$\begin{aligned} lag_{total} &= 0 \\ lead_{total} &= |total| \end{aligned}$$

Application Criteria for Linear Addition

Linear Addition will be applied where either:

- (i) $[\max(lag_i) = 0 \text{ or } \max(lead_i) = 0]$

(All Generating Units providing lagging (or zero) reactive energy or all Generating Units

providing leading (or zero) reactive energy)

or:

- (ii) $[\min(\text{lag}_i) > 0 \text{ and } \min(\text{lead}_i) > 0]$

(All Generating Units providing both leading and lagging reactive energy where the group of leading and lagging metered values are such that the maximum group value is no greater than 1.1 times the minimum group value)

ie: maximum lagging metered value $\leq 1.1 \times$ minimum lagging metered value

maximum leading metered value $\leq 1.1 \times$ minimum leading metered value.

Otherwise separation of totals is the applicable methodology, rather than Linear Addition.

5. CATEGORY C

The following meter aggregation methodologies cover those cases where the reactive power equipment is an auxiliary gas turbine generating unit (GT), connected to the unit auxiliary board of a main Generating Unit.

In such cases the export from the GT is either via the unit (UTX) / generator (GTX) step-up transformer when the main Generating Unit is synchronised or via power station interconnectors and the station (STX) step-up transformer when the main Generating Unit is not synchronised. Figure (iv) shows one such arrangement and indicates the typical position of the Reactive Power Meters.

By applying tests to determine whether both or only one of the main Generating Unit and the GT are synchronised, the appropriate Meter loss adjustment and Meter aggregation methodologies for the operating conditions are determined.

When the GT is synchronised it may be producing both active and reactive power or operating as a synchronous compensator producing only reactive power.

Figure (iv)

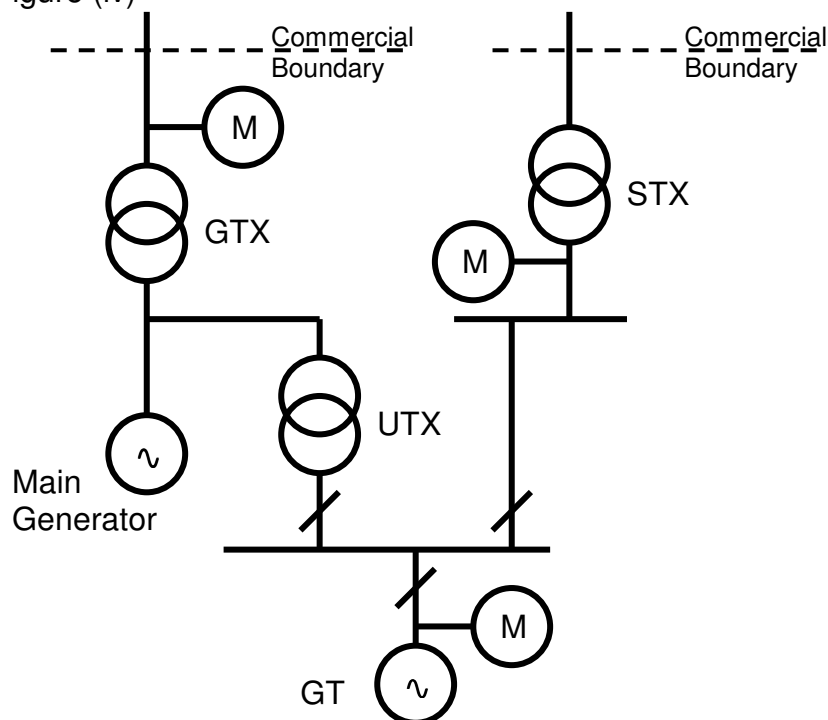

In order to provide Mvarh import and Mvarh export values for the GT at the HV side of the generator and station step-up transformers when both the main Generating Unit and/or the GT are synchronised, appropriate Meter loss adjustment factors are required to be applied to the GT Meter readings. These will be dependent upon actual site/plant arrangement and agreed reference operating conditions. These will be subject to agreement on a site by site basis between The Company and the User.

Methodology

The main Generating Unit is identified as synchronised by the condition $A_{ij} > 5\text{MWh}$ in a Settlement Period.

The GT is identified as synchronised by the metered Mvarh import or export value, measured at the GT Meter, being greater than 2.5 Mvarh in a Settlement Period.

Let:

Grlag and Grlead = the Mvarh export and import values at the HV side of the generator step-up transformer.

Gtlagcomp and Gtleadcomp = the Mvarh export and import values of the GT as adjusted to the values at the Commercial Boundary by the application of a Meter loss adjustment factor based on a "predominant

reactive energy flow path”, agreed between The Company and the User for that Meter. (ie One Meter loss adjustment factor will apply for export values and one Meter loss adjustment factor will apply to import values whether the reactive flow is via the generator or station step-up transformer.)

Three case scenarios are dealt with below

1. Where only the main Generating Unit is synchronised:-

Payments will be made for the main Generating Unit only and will be calculated utilising the G_{rlag} and/or G_{rlead} Mvarh export and import values at the main Generating Unit payment rate.

2. Where only the GT is synchronised:-

Payments will be made for the GT only and will be calculated utilising the appropriate GT Mvarh export and import values, adjusted in accordance with the appropriate meter loss adjustment factor at the GT payment rate.

3. Where both the main Generating Unit and the GT are synchronised:-

(a) Where $G_{rlag} \geq G_{tlagcomp}$

Payments will be calculated as follows:-

- i) For the main Generating Unit, $(G_{rlag} - G_{tlagcomp})$ Mvarh export values at the main Generating Unit payment rate, and
- ii) For the GT, $G_{tlagcomp}$ Mvarh export value at the GT payment rate.

(b) Where $G_{rlag} < G_{tlagcomp}$

- i) For the main Generating Unit, $(G_{rlag} - G_{tlagcomp})$ Mvarh export values will be zero and so no payment will be due at the main Generating Unit payment rate, and
- ii) For the GT, $G_{tlagcomp}$ Mvarh export value at the GT payment rate.

(c) Where $G_{rlead} \geq G_{tleadcomp}$

Payments will be calculated as follows:-

- i) For the main Generating Unit, (Grlead-Gtleadcomp) Mvarh import values at the main Generating Unit payment rate, and
 - ii) For the GT, Gtleadcomp Mvarh import value at the GT payment rate.
- (d) Where $Grlead < Gtleadcomp$
- i) For the main Generating Unit, (Grlead-Gtleadcomp) Mvarh export values will be zero and so no payment will be due at the main Generating Unit payment rate, and
 - ii) For the GT, Gtleadcomp Mvarh export value at the GT payment rate.

The above four cases apply to instances where there is all leading or all lagging reactive energy during a Settlement Period **and** where both leading and lagging operation occurs in a Settlement Period.

6. CATEGORY D

This category covers the case where the Generating Unit connected at the Commercial Boundary also supplies an embedded load.

In such cases the reactive power produced by the Generating Unit needs to be determined in relation to the reactive nature of the load and whether the Generating Unit has been despatched to provide lagging or leading reactive power. Figure (v) shows one such arrangement and indicates the typical positions of the Reactive Power Meters.

Figure (v)

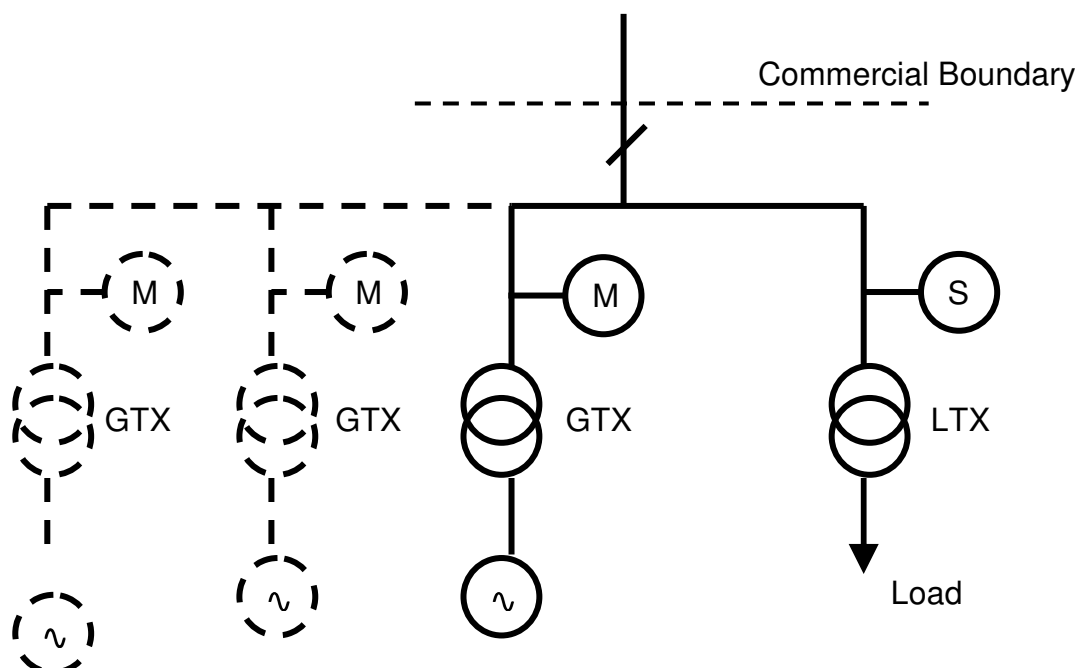

Methodology

The Metering Codes of Practice One and Two define the following convention to be used for determining the flow of energy:

Flow of Active Energy	Power Factor	Flow of Reactive Energy
Import	LAGGING	Import
Import	LEADING	Export
Import	UNITY	Zero
Export	LAGGING	Export
Export	LEADING	Import
Export	UNITY	Zero

This means that for a Load, the Leading Mvars will be exporting (towards the Commercial Boundary), whereas leading Mvars for a Generating Unit will be importing (away from the Commercial Boundary).

In order to reflect the impact of the embedded load on the reactive power from the Generating Unit at the Commercial Boundary then three aggregation methodologies will need to apply.

Let

G_{rlag} and G_{rlead} = the Mvarh export and import values at the HV side of the Generating Unit step-up transformer (M in figure v).

Ldlag and Ldlead = the Mvarh import and export values at the HV side of the Embedded Load transformer (S in figure v).

Three case scenarios are dealt with below

1. Where both Unit and Load are exporting (Grlag and Ldlead) or when both Unit and Load are importing (Grlead and Ldlag):-

Payments will be made for the Generating Unit only and will be calculated utilising the Grlag and/or Grlead Mvarh export and import values at the main Generating Unit payment rate.

2. Where Unit is exporting and Load importing (Grlag and Ldlag):-

Payments will be made for the Generating Unit less the effect of the Embedded Load and will be calculated using $(Grlag - Ldlag)$ values at the main Generating Unit payment rate. Where $(Grlag - Ldlag) < 0$ then the value at the main Generating Unit will be zero.

3. Where Unit is importing and Load exporting (Grlead and Ldlead):-

Payments will be made for the Generating Unit less the effect of the Embedded Load and will be calculated using $(Grlead - Ldlead)$ values at the main Generating Unit payment rate. Where $(Grlead - Ldlead) < 0$ then the value at the main Generating Unit will be zero.

The above three cases apply to instances where there is all leading or all lagging reactive energy during a Settlement Period **and** where both leading and lagging operation occurs in a Settlement Period.

Where there is more than one Generating Unit (as indicated by the plant drawn by dotted lines in Figure v), then the total Generating Mvars (Grlead and Grlag) will be determined in accordance with Methodology B in this document.