

Gas Industry Standard

GIS/TE/E1.8:2006

Specification for

**Access tool for live entry into a low pressure
polyethylene service**

nationalgrid

Northern
Gas Networks

Scotia
Gas Networks plc

WALES&WEST
UTILITIES

Contents

	Page
Foreword	iii
Mandatory and non-mandatory requirements	iii
Disclaimer	iii
Brief history	iv
1 Scope	1
2 Normative references	1
3 Terms and definitions	1
4 Construction and materials	1
4.1 All components shall be suitable for use with natural gas.	1
4.2 The equipment shall be resistant to petroleum-based products such as oil, petrol and diesel, etc.	1
5 Design	1
6 Performance	2
6.1 Proof test	2
6.2 Attachment of the tool to a service fitting	2
6.3 Closure seal pressure test	2
6.4 Operation	2
6.5 Tool retention	3
7 User instructions	3
8 Marking	3
Annex A (normative) Proof test of tool	4
Annex B (normative) Static sealing tests	6
Annex C (normative) Operational tests	9
Annex D (normative) Tool retention test	13
Figure A.1 — Proof test on tool body	5
Figure B.1 — Static sealing test arrangement	7
Figure C.1 — Removal and re-fitting of an internal plastic plug from a service fitting	11
Figure C.2 — Insertion and retrieval of tracer wire probe	12
Figure D.1 — Tool retention test	14

Foreword

Gas Industry Standards (GIS) are revised, when necessary, by the issue of new editions. Users should ensure that they are in possession of the latest edition. Contractors and other users external to Gas Transporters should direct their requests for copies of a GIS to the department or group responsible for the initial issue of their contract documentation.

Comments and queries regarding the technical content of this document should be directed in the first instance to the contract department of the Gas Transporter responsible for the initial issue of their contract documentation.

This standard calls for the use of procedures that may be injurious to health if adequate precautions are not taken. It refers only to technical suitability and does not absolve the user from legal obligations relating to health and safety at any stage.

Compliance with this engineering document does not confer immunity from prosecution for breach of statutory or other legal obligations.

Mandatory and non-mandatory requirements

For the purposes of a GIS the following auxiliary verbs have the meanings indicated:

- can** indicates a physical possibility;
- may** indicates an option that is not mandatory;
- shall** indicates a GIS requirement;
- should** indicates best practice and is the preferred option. If an alternative method is used then a suitable and sufficient risk assessment needs to be completed to show that the alternative method delivers the same, or better, level of protection.

Disclaimer

This engineering document is provided for use by Gas Transporters and such of their contractors as are obliged by the terms of their contracts to comply with this engineering document. Where this engineering document is used by any other party, it is the responsibility of that party to ensure that the engineering document is correctly applied.

Brief history

First published as T/SP/TE/E1.8 Edited by BSI in accordance with BS 0-3:1997	September 2004 August 2006
---	-------------------------------

© **National Grid**, on behalf of National Grid, Northern Gas Networks, Scotia Gas Networks, and Wales and West Utilities.

This Gas Industry Standard is copyright and must not be reproduced in whole or in part by any means without the approval in writing of either National Grid, Northern Gas Networks, Scotia Gas Networks, or Wales and West Utilities.

1 Scope

This Gas Industry Standard specifies requirements for an access tool for live entry into a low pressure (LP) polyethylene service connected to a service fitting. This allows a detection probe to be inserted into the attached polyethylene service pipe. Typical service fittings included a house entry tee, or an emergency control valve.

The tool is for use at low pressure conditions, to trace the layout of a polyethylene service pipe up to a maximum length of 50 m.

2 Normative references

The following referenced documents are indispensable for the application of this document. For dated references, only the edition cited applies. For undated references, the latest edition of the referenced document (including any amendments) applies.

Formal standards

BS EN 682:2002, *Elastomeric seals — Materials requirements for seals used in pipes and fittings carrying gas and hydrocarbon fluids.*

Gas Industry Standards

GIS/E48, *Specification for polyethylene service line tracing equipment.*

3 Terms and definitions

For the purposes of this standard the following terms and definitions apply.

3.1

service fitting

fitting used to connect a service pipe between the mains and meter

3.2

intermediate seal

element used to connect the tool to a service fitting

3.3

closure seal

element which forms a gas tight seal between the tool and inserted equipment

4 Construction and materials

4.1 All components shall be suitable for use with natural gas.

4.2 The equipment shall be resistant to petroleum-based products such as oil, petrol and diesel, etc.

5 Design

5.1 The tool shall be capable of being connected to an appropriate service fitting to facilitate live access to a low pressure polyethylene service pipe. It shall be possible to attach and remove the tool without disturbing the service fitting. It shall remain attached to the service fitting under all operating and pressure conditions.

5.2 The tool shall incorporate a shut-off device so that gas can be contained in order to facilitate access to the service fitting, insertion and retraction of the tracer wire, and subsequent re-commissioning of the service fitting.

5.3 The tool shall have provision for a secondary restraint mechanism to prevent it from becoming detached from the service fitting under all operating conditions. There shall be provision to proof pressure test the tool, and its attachment, to a service fitting to a pressure of 100 mbar prior to exposure to live gas conditions.

5.4 Under static conditions the tool shall be capable of retaining live gas at low pressure operating conditions, and the pressure drop from the tool shall not exceed 1 mbar over a 5 min period at a test pressure of 100 mbar. Under operational conditions, including live access to a polyethylene service and the insertion and retraction of a tracer wire into the polyethylene service, the pressure drop shall not exceed 5 mbar over a 5 min period at a test pressure of 100 mbar.

5.5 The gland seal material shall be in accordance with BS EN 682. The equipment shall have no sharp edges or other protrusions that can injure hands, fingers, etc. when in operation.

6 Performance

6.1 Proof test

When tested in accordance with Annex A, the pressure drop across the tool shall be no more than 1 mbar over the 30 min period.

6.2 Attachment of the tool to a service fitting

6.2.1 When the intermediate seal between the tool and the service fitting is tested in accordance with **B.1** the pressure drop shall be no more than 1 mbar over a 5 min period.

NOTE The purpose of this test is to demonstrate that the sealing arrangement between the tool and the service fitting can adequately contain the maximum operating pressure.

6.2.2 Where there are variations of service fittings that are to be accommodated by the intermediate seal, the intermediate seal shall be tested with each type of service fitting. Where a different intermediate seal is required to accommodate a different service fitting, each intermediate seal shall be clearly identified as to which service fittings it will accommodate.

6.3 Closure seal pressure test

When tested in accordance with **B.2**, the pressure drop across the closure seal shall be no more than 1 mbar over a 1 min period.

NOTE This test is required to check that live gas will be contained prior to the introduction of any equipment through the closure gland.

6.4 Operation

6.4.1 When tested in accordance with **C.1**, the pressure drop across the closure seal shall be no more than 5 mbar during the complete operation.

6.4.2 When tested in accordance with **C.2**, the pressure drop across the closure gland during insertion and retrieval shall not exceed 5 mbar.

6.5 Tool retention

When tested in accordance with Annex D, the tool-retaining system shall be able to take the strain without breaking or stretching more than 5 mm and remain leak-tight such that the pressure drop is no more than 1 mbar over a 5 min period.

7 User instructions

User instructions shall be provided with each item of equipment.

8 Marking

Products conforming to GIS/TE/E1.8 shall be permanently marked with the following information:

- a) the number and date of this standard, i.e. GIS/TE/E1.8:2006 ¹⁾;
- b) the name or trademark of the manufacturer or their appointed agent;
- c) the manufacturer's contact details;
- d) where authorized, the product conformity mark of a third party certification body, e.g. BSI Kitemark.

NOTE Attention is drawn to the advantages of using third party certification of conformance to a standard.

¹⁾ Marking GIS/TE/E1.8:2006 on or in relation to a product represents a manufacturer's declaration of conformity, i.e. a claim by or on behalf of the manufacturer that the product meets the requirements of the standard. The accuracy of the claim is therefore solely the responsibility of the person making the claim. Such a declaration is not to be confused with third party certification of conformity, which may also be desirable.

Annex A (normative)

Proof test of tool

A.1 Principle

The capability of the tool itself to retain pressure at the low pressure fault condition of 350 mbar is determined.

A.2 Apparatus

A.2.1 *Cap*, to close off the top of the tool at the closure seal.

A.2.2 *Cap*, to close of the lower section of the tool with a connection port for the pressure source and the pressure monitoring device.

A.2.3 *Pressure source*, at 350 mbar.

A.2.4 *Pressure monitoring device*, capable of measuring up to 375 mbar in steps of 1 mbar with an accuracy of ± 1 mbar.

A.3 Test sample

One tool shall be tested.

A.4 Procedure

A.4.1 Assemble the tool with a cap to blank-off the closure seal. Connect a cap with a test port to the other end of the tool in accordance with Figure A.1.

NOTE The intermediate seal does not need to be in place for this test since it is the integrity of all components and manufactured joints that are being assessed.

During this test the tool shut-off device shall be open.

A.4.2 Pressure test the system to a pressure of 350 mbar for a period of 30 min.

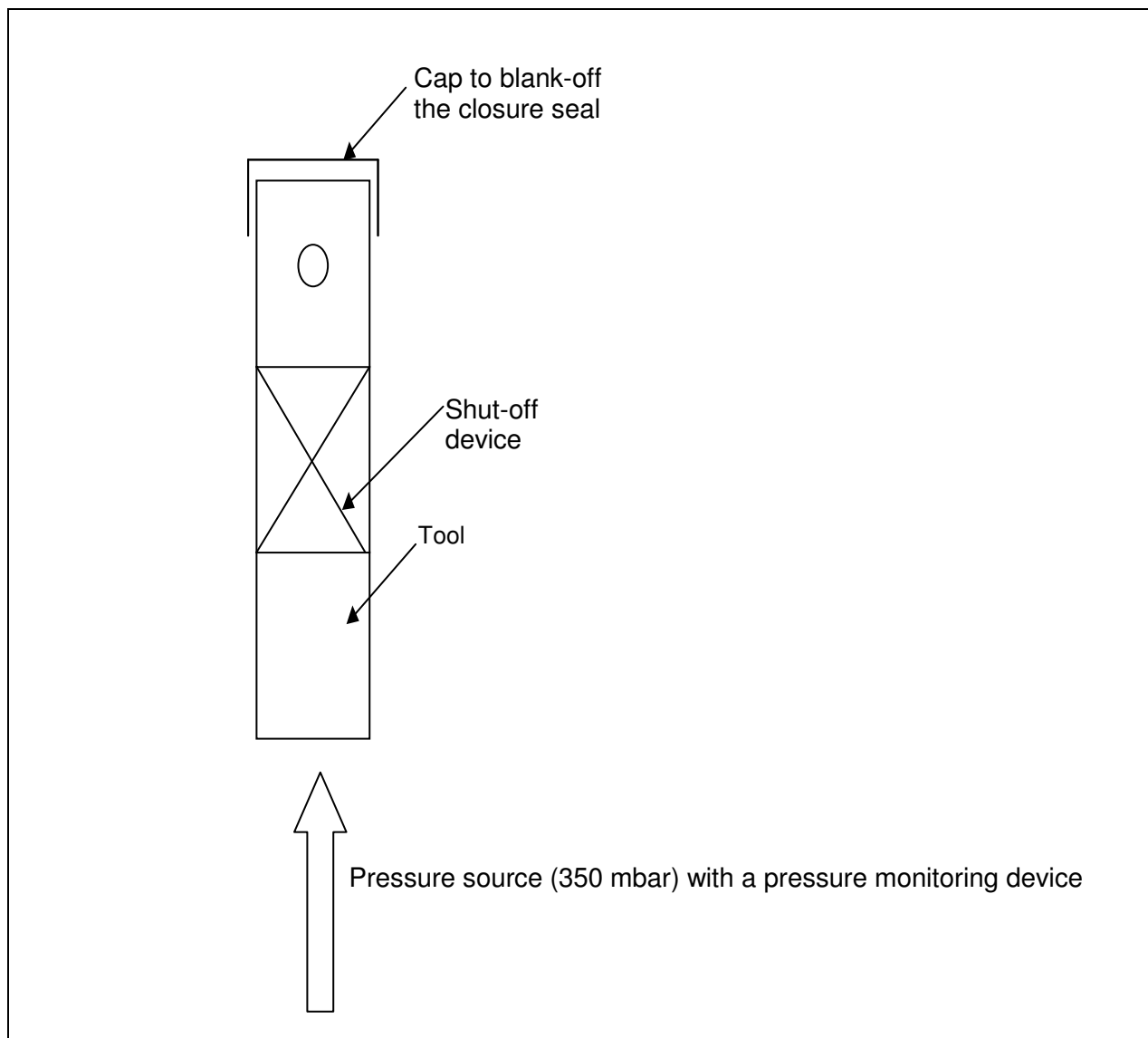

Figure A.1 — Proof test on tool body

A.5 Expression of results

Record and report the following:

- a) test pressure; and
- b) test duration.

A.6 Test report

The test report shall include the following information:

- a) reference to this standard, i.e. GIS/TE/E1.8:2006;
- b) the results of the termination;
- c) any additional factors which may have affected the results of the test.

Annex B (normative)
Static sealing tests

B.1 Attachment of the tool to a service fitting

B.1.1 Principle

The capability of the tool, its seals and valve to contain pressures, that will be experienced during normal operating conditions, is determined.

B.1.2 Apparatus

B.1.2.1 Low pressure service fitting, for example, a standard 1 in British Standard pipe thread (BSP) by 32 mm polyethylene 'house entry tee' could be used.

B.1.2.2 Pressure source, at 100 mbar.

B.1.2.3 Pressure monitoring device, capable of measuring up to 125 mbar in steps of 1 mbar with an accuracy of ± 1 mbar.

B.1.3 Test sample

One tool shall be tested.

B.1.4 Procedure

Assemble the tool onto a service fitting in accordance with Figure B.1. Close the shut-off device on the tool. Apply a pressure of 100 mbar into the system from the service fitting end and then isolate the tool from the pressure source. Hold the pressure for 5 min.

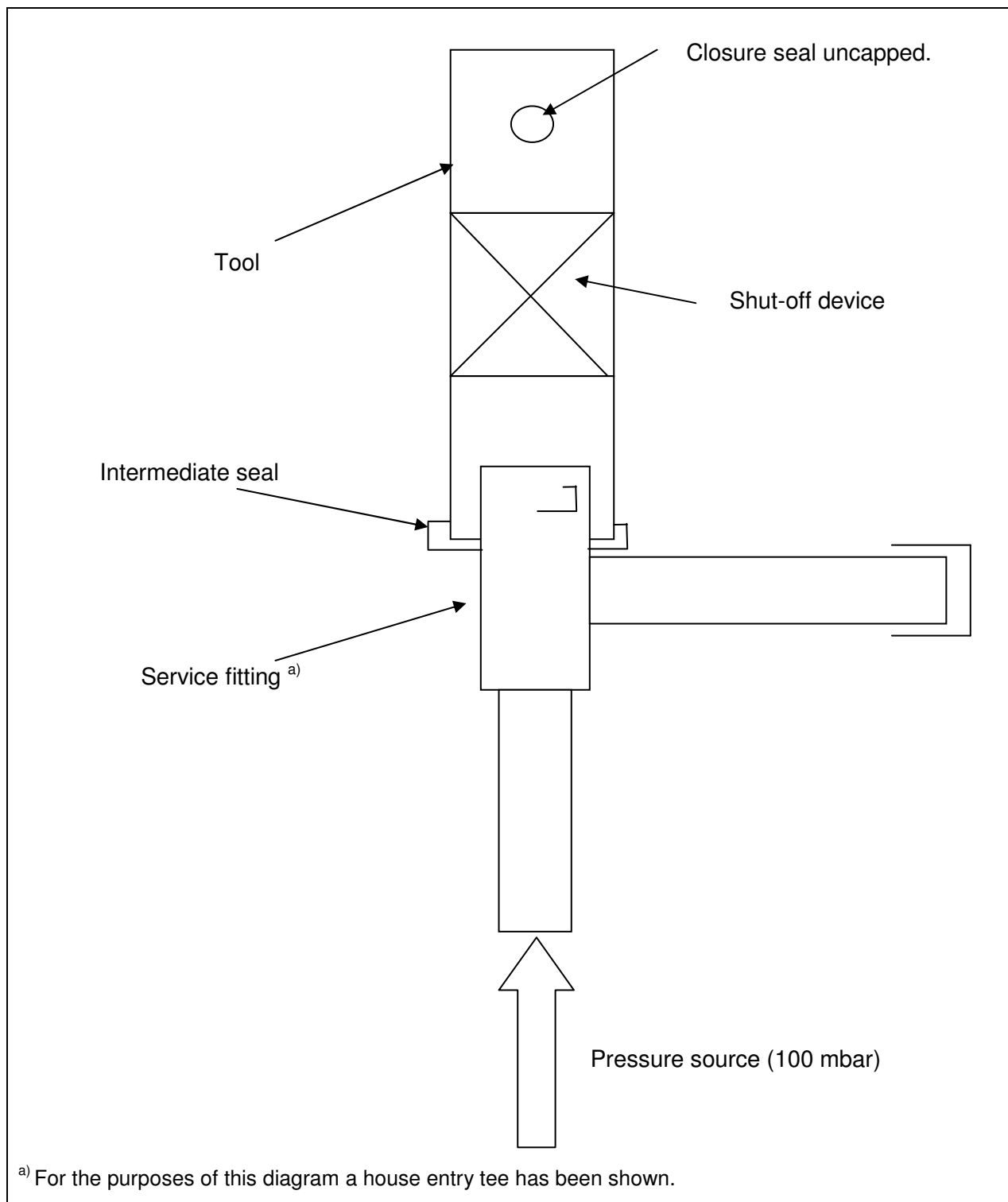

Figure B.1 — Static sealing test arrangement

B.1.5 Expression of results

Record and report the following:

- a) test pressures, in mbar.
- b) test durations, in mins.

B.1.6 Test report

The test report shall include the following information:

- a) reference to this standard, i.e. GIS/TE/E1.8:2006;
- b) the results of the termination;
- c) any additional factors which may have affected the results of the test.

B.2 Closure seal pressure test

B.2.1 Principle

The capability of the tool, its seals and valve to contain pressures, that will be experienced during normal operating conditions, is determined.

B.2.2 Apparatus

B.2.2.1 *Low pressure service fitting*, for example, a standard 1 in BSP by 32 mm polyethylene 'house entry tee' could be used.

B.2.2.2 *Pressure source*, at 100 mbar.

B.2.2.3 Pressure monitoring device, capable of measuring up to 125 mbar in steps of 1 mbar with an accuracy of ± 1 mbar.

B.2.3 Test sample

One tool shall be tested.

B.2.4 Procedure

Assemble the tool onto the service fitting in accordance with Figure B.1. Open the shut-off device on the tool. Apply a pressure to 100 mbar, then isolate the tool from the pressure source. Hold the pressure for 1 min.

B.2.5 Expression of results

Record and report the following:

- a) test pressures, in mbar;
- b) test durations, in mins.

B.2.6 Test report

The test report shall include the following information:

- a) reference to this standard, i.e. GIS/TE/E1.8:2006;
- b) the results of the termination;
- c) any additional factors which may have affected the results of the test.

Annex C (normative)

Operational tests

C.1 Removal and refitting of an internal plug from a service fitting

C.1.1 Principle

The functionality of the tool, its seals and valve during normal operating conditions is determined. In particular, this establishes whether access can be gained to a service fitting and that an internal plug can be removed and refitted.

C.1.2 Apparatus

C.1.2.1 *A low pressure service fitting*, for example a standard 1 in BSP by 32 mm polyethylene 'house entry tee' could be used.

C.1.2.2 *Pressure source*, at 100 mbar.

C.1.2.3 *Pressure monitoring device*, capable of measuring up to 125 mbar in steps of 1 mbar with an accuracy of ± 1 mbar.

C.1.3 Test sample

One tool shall be tested.

C.1.4 Procedure

Assemble the tool onto the service fitting and connect to a fixed volume of gas at a pressure of 100 mbar in accordance with Figure C.1. Insert the extractor tool into the system until it is resting in the internal plug. Pressurize the tool to 100 mbar to equalize the pressure above and below the internal plug. Operate the extractor tool so that it couples with the internal plug. Undo the internal plug. Pull the extractor backwards so that the internal plug is free from the service fitting. Monitor the pressure during the insertion.

C.1.5 Expression of results

Record and report the following:

- a) test pressure;
- b) test duration.

C.1.6 Test report

The test report shall include the following information:

- a) reference to this standard, i.e. GIS/TE/E1.8:2006;
- a) the results of the termination;
- b) any additional factors which may have affected the results of the test.

C.2 Insertion and retrieval of tracer probe from a service fitting

C.2.1 Principle

The functionality of the tool, its seals and valve during normal operating conditions is determined. In particular, this establishes whether access can be gained to a service fitting and that a tracer device can be passed through the body of the tool and into the service fitting.

C.2.2 Apparatus

C.2.2.1 *A low pressure service fitting*, for example a standard 1 in BSP by 32 mm polyethylene 'house entry tee' could be used.

C.2.2.2 *Pressure source*, at 100 mbar.

C.2.2.3 *Pressure monitoring device*, capable of measuring up to 125 mbar in steps of 1 mbar with an accuracy of ± 1 mbar.

C.2.2.4 *Tracer device*, in accordance with GIS/E48.

C.2.3 Test sample

One tool shall be tested.

C.2.4 Procedure

Assemble the tool onto a service fitting with a 50 m service pipe extension in accordance with Figure C.2. Insert the tracer probe gland into the system and through the shut-off device. Pressurize the system to 100 mbar using a fixed volume of gas. Insert the tracer probe into the system for the full 50 m of pipework. Monitor the pressure during the insertion. Retrieve the tracer probe back into the tool. Monitor the pressure during the retraction.

C.2.5 Expression of results

Record and report the following:

- a) test pressure;
- b) test duration.

C.2.6 Test report

The test report shall include the following information:

- a) reference to this standard, i.e. GIS/TE/E1.8:2006;
- b) the results of the termination;
- c) any additional factors which may have affected the results of the test.

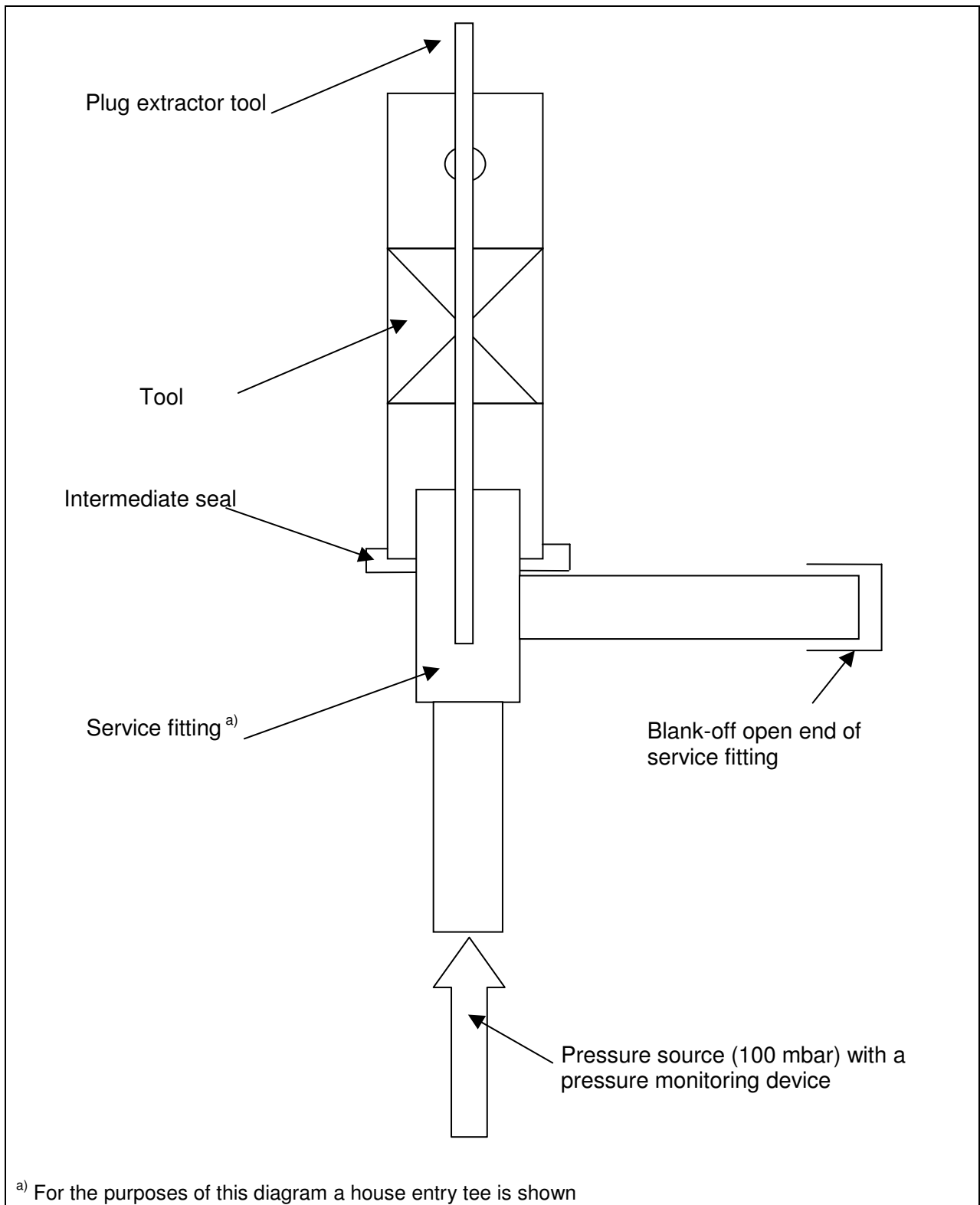

Figure C.1 — Removal and re-fitting of an internal plastic plug from a service fitting

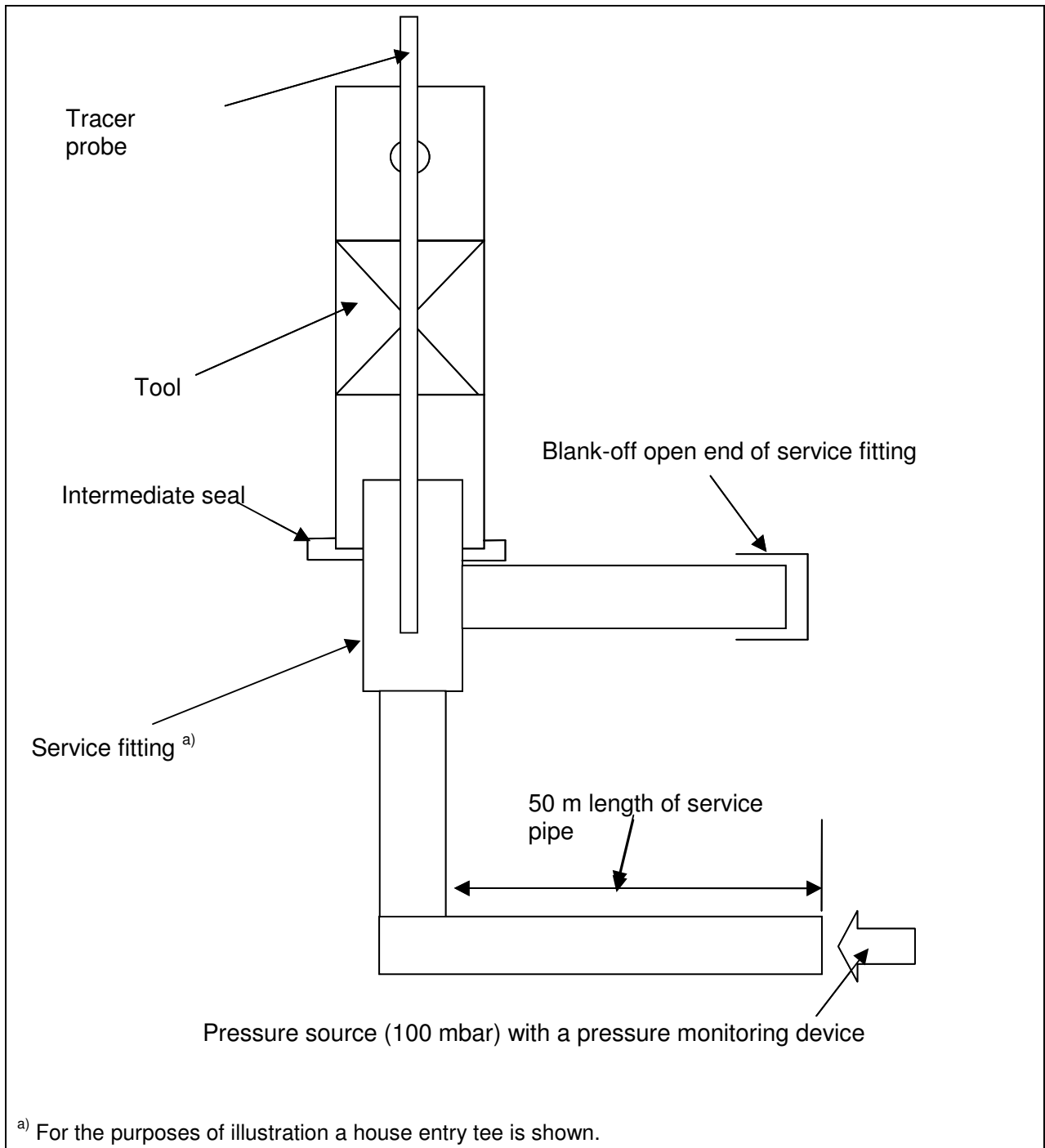

Figure C.2 — Insertion and retrieval of tracer wire probe

Annex D (normative)

Tool retention test

D.1 Principle

The functionality of the tool retaining system is determined.

D.2 Apparatus

D.2.1 *Load*, of 6 kg.

D.2.2 *Cap*, to blank-off service fitting.

D.2.3 *Pressure source*, at 100 mbar.

D.2.4 *Pressure monitoring device*, capable of measuring up to 125 mbar in steps of 1 mbar with an accuracy of ± 1 mbar.

D.3 Test sample

One fitting shall be tested.

D.4 Procedure

D.4.1 Assemble the tool onto the service fitting in accordance with Figure D.1. If fitted ensure that the restraining system is securely holding the tool and service fitting together. Ensure that the shut-off device is closed.

D.4.2 Fit a cap to blank-off the horizontal section of the service fitting and pressure test the system to 100 mbar to check for soundness.

D.4.3 With an applied pressure of 100 mbar apply an axial pull load (P_1) of 6 kg to the tool to test the restraining system. Remove the axial pull load.

D.4.4 With an applied pressure of 100 mbar apply a load (P_2) at right angles to the tool's vertical plane of 6 kg.

D.5 Expression of results

Record and report the following for each loading condition:

- a) test pressure,
- b) applied load,
- c) test duration;
- d) any displacement of the tool under loading.

D.6 Test report

The test report shall include the following information:

- a) reference to this standard, i.e. GIS/TE/E1.8:2006;
- b) the results of the termination;
- c) any additional factors which may have affected the results of the test.

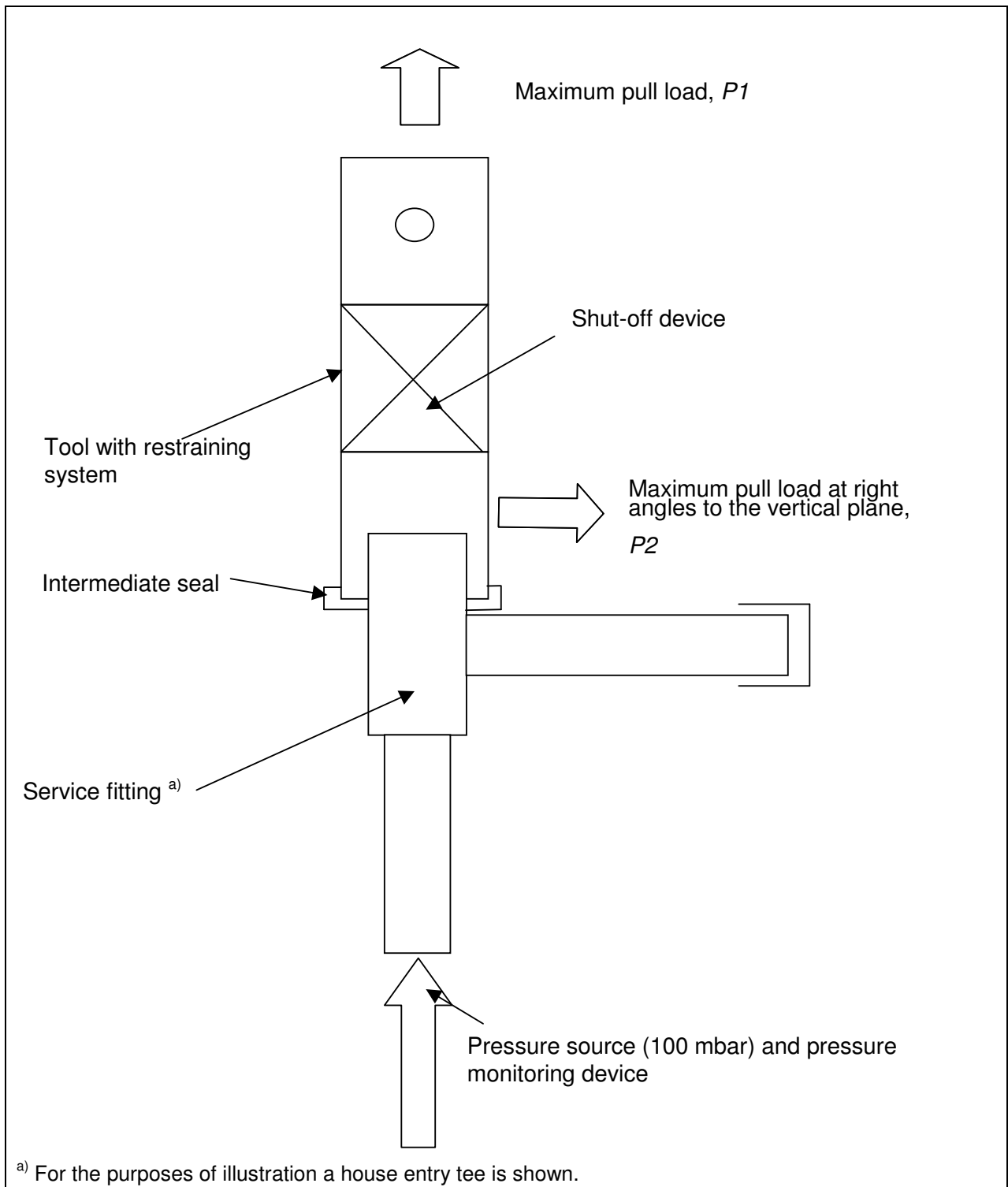

Figure D.1 — Tool retention test