

Embedded Generation

TCMF

15 October 2007

nationalgrid

Transmission Access for Distributed Generation

Ofgem's provisional views

- ◆ Ofgem think there is a case for change
 - ◆ Cost-reflectivity
 - ◆ Allocation of transmission access
 - ◆ Commercial proportionality
- ◆ Cost-reflectivity
 - ◆ NGET should review drivers of costs associated with residual TNUoS charge, taking into account the impact of DG on such costs
 - ◆ DG should pay less (avoids some network costs) but value requires review
 - ◆ Review should address treatment of generation under 100MW connected at 132kV across GB

Embedded Benefit

What is it?

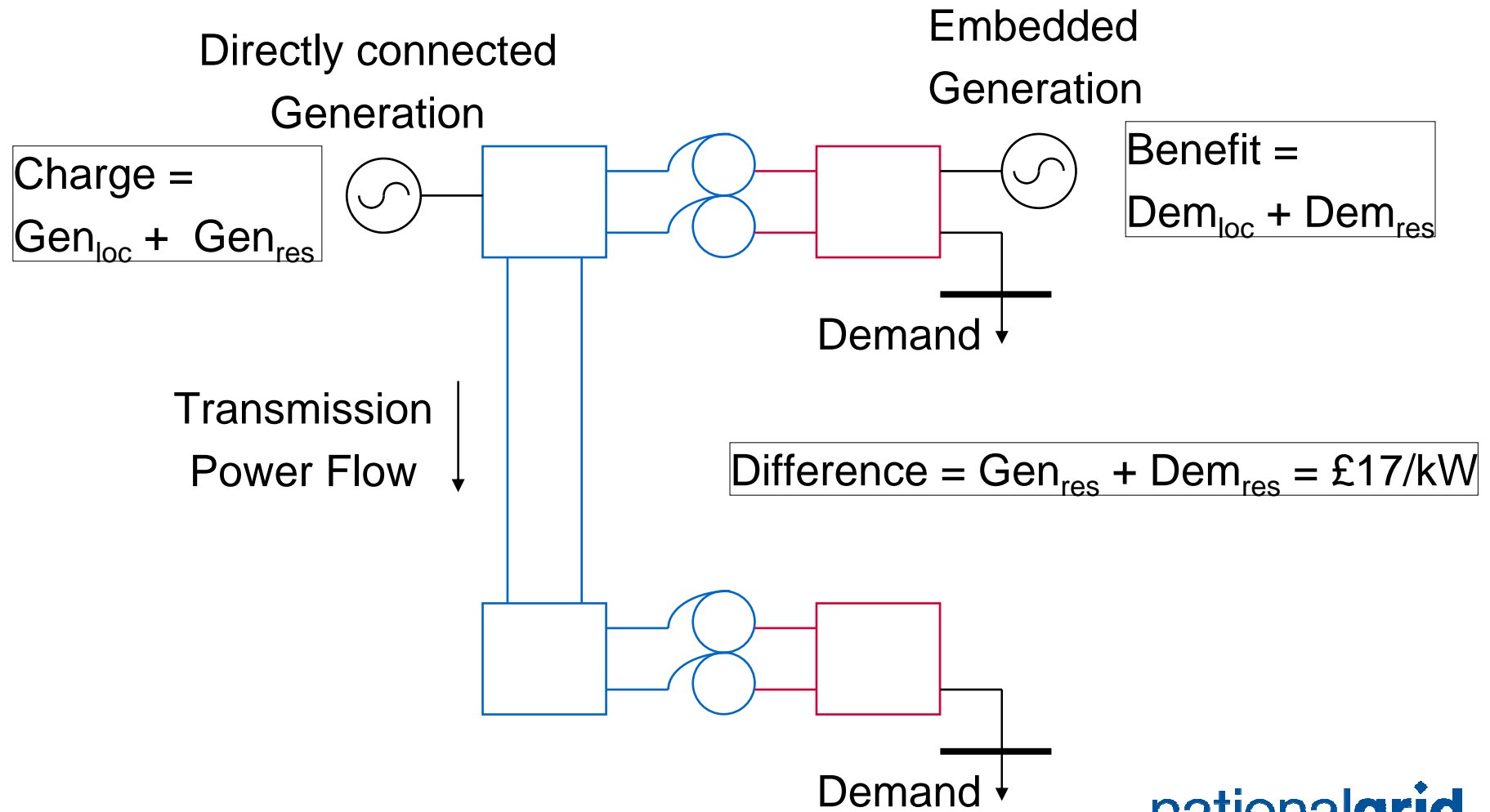

Embedded Benefit

What is the impact of DG?

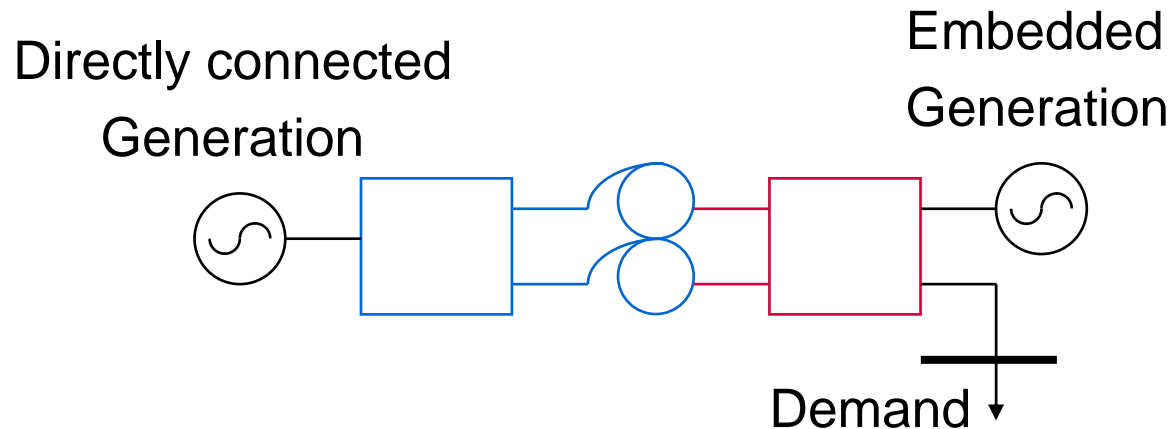

- ◆ Investment savings are two-fold:
 - ◆ Cost of connecting new generation
 - ◆ Less local works (if export less than designed import)
 - ◆ Exit substation assets
 - ◆ Off-set proposed reinforcements

Embedded Benefit

Avoided transmission costs

- ◆ Avoided costs of connecting new generation

	Local (£/kW)
South & South West	15
Thames Estuary	15
London	60
South Wales	15
East of England & Home Counties	10
West Midlands	5
East Midlands	5
North West & North Wales	30
Yorkshire & Lincolnshire	15
North East	15

- ◆ England & Wales average of £18.5/kW
- ◆ Annuitised over 40 years to approximately £1.5/kW

Embedded Benefit

Avoided transmission costs

- ◆ Avoided costs for investing to meet additional demand
- ◆ Indicative work suggests an England & Wales average of ~£60/kW
- ◆ Annuitised over 40 years this would give approximately £5/kW
- ◆ Total avoided transmission costs could therefore be in the region of £6.5/kW

Embedded Benefit

Next steps

- ◆ More detailed analysis of the investment avoided
- ◆ Further analysis of the impact of DG on residual element of the TNUoS Tariff
- ◆ Further industry discussion at CISG/TCMF
- ◆ Consideration and consultation of the appropriate framework

Embedded Generation

TCMF

15 October 2007

nationalgrid