

# Gas Industry Standard

GIS/EFV1:2006

---

---

Specification for

**Flow limiters for polyethylene services operating at pressures above 75 mbar and not exceeding 2.0 bar and for gas flows not exceeding 6 m<sup>3</sup>h<sup>-1</sup>**

---

---

nationalgrid

Northern  
Gas Networks 

 Scotia  
Gas Networks plc

 WALES&WEST  
UTILITIES



## Contents

|  | Page |
|--|------|
| Foreword   | iii  |
| Mandatory and non-mandatory requirements         | iii  |
| Disclaimer                                       | iii  |
| Brief history                                    | iv   |
| Introduction                                     | 1    |
| <br>   |      |
| 1 Scope  | 1    |
| 2 Normative references                           | 1    |
| 3 Terms and definitions                          | 2    |
| 4 Materials                                      | 2    |
| 5 Design   | 2    |
| 5.1 General                                      | 2    |
| 5.2 Integral valves                              | 3    |
| 5.3 Maximum service pipe length for 32 mm valves | 3    |
| 6 Performance requirements                       | 3    |
| 6.1 Short term pressure test                     | 3    |
| 6.2 Long term strength test                      | 4    |
| 6.3 Surge flow test                              | 4    |
| 6.4 Trip flow rate                               | 4    |
| 6.5 Bypass flow rate                             | 4    |
| 6.6 Reset  | 4    |
| 6.7 Pressure loss test                           | 4    |
| 6.8 Contaminants test                            | 4    |
| 6.9 Thermal cycling test                         | 4    |
| 6.10 Impact test                                 | 4    |
| 7 Testing  | 4    |
| 7.1 Approval testing (type testing)              | 4    |
| 7.2 Production testing                           | 5    |
| 8 Test samples                                   | 6    |
| 8.1 Approval testing (type testing)              | 6    |
| 8.2 Production testing                           | 6    |
| 9 Control of test conditions                     | 6    |
| 9.1 General                                      | 6    |
| 9.2 Pneumatic pressure testing                   | 6    |
| 10 Marking                                       | 6    |
| 11 Identification tag                            | 7    |
| 12 Instructions                                  | 7    |
| 13 Packaging and storage                         | 7    |
| <br>   |      |
| Annex A (normative) Short term pressure test     | 8    |
| Annex B (normative) Long term strength test      | 9    |
| Annex C (normative) Surge flow test              | 10   |
| Annex D (normative) Trip flow rate               | 12   |
| Annex E (normative) Bypass flow rate             | 13   |
| Annex F (normative) Reset                        | 14   |
| Annex G (normative) Pressure loss test           | 15   |
| Annex H (normative) Contaminants test            | 18   |
| Annex I (normative) Thermal cycling test         | 19   |
| Annex J (normative) Impact test                  | 20   |

**Contents** *(continued)*

|   | Page |
|---|------|
| Figure C.1 — Typical apparatus for testing flow limiters                              | 11   |
| Figure G.1 — Typical assembly method for integral valve specimen for pressure testing | 17   |
| Figure J.1 — Typical apparatus for testing flow limiters                              | 22   |
| Table 1 — Type test requirements  | 5    |
| Table 2 — Production test requirements  | 5    |
| Table C.1 — Surge test flow rate for valves   | 10   |
| Table D.1 — Minimum and maximum trip flow rate for valves                             | 12   |
| Table G.1 — Maximum allowable pressure drop across valves                             | 16   |

## Foreword

Gas Industry Standards (GIS) are revised, when necessary, by the issue of new editions. Users should ensure that they are in possession of the latest edition. Contractors and other users external to Gas Transporters should direct their requests for copies of a GIS to the department or group responsible for the initial issue of their contract documentation.

Comments and queries regarding the technical content of this document should be directed in the first instance to the contract department of the Gas Transporter responsible for the initial issue of their contract documentation.

This standard calls for the use of procedures that may be injurious to health if adequate precautions are not taken. It refers only to technical suitability and does not absolve the user from legal obligations relating to health and safety at any stage.

Compliance with this engineering document does not confer immunity from prosecution for breach of statutory or other legal obligations.

## Mandatory and non-mandatory requirements

For the purposes of a GIS the following auxiliary verbs have the meanings indicated:

- can** indicates a physical possibility;
- may** indicates an option that is not mandatory;
- shall** indicates a GIS requirement;
- should** indicates best practice and is the preferred option. If an alternative method is used then a suitable and sufficient risk assessment needs to be completed to show that the alternative method delivers the same, or better, level of protection.

## Disclaimer

This engineering document is provided for use by Gas Transporters and such of their contractors as are obliged by the terms of their contracts to comply with this engineering document. Where this engineering document is used by any other party, it is the responsibility of that party to ensure that the engineering document is correctly applied.

## Brief history

|   |   |
|---|---|
| First published as T/SP/EFV1<br>Editorial update to comply with GRM<br>Edited by BSI in accordance with BS 0-3:1997<br>Edited by NG. Table 2 Annex references corrected | April 2004<br>August 2004<br>August 2006<br>December 2006 |
|---|---|

© **National Grid**, on behalf of National Grid, Northern Gas Networks, Scotia Gas Networks, and Wales and West Utilities.

This Gas Industry Standard is copyright and must not be reproduced in whole or in part by any means without the approval in writing of either National Grid, Northern Gas Networks, Scotia Gas Networks, or Wales and West Utilities.

## Introduction

A recommendation was made by the HSE Gas Safety Management Regulations Working Group in February 2000, that flow limiters should be installed in medium pressure services. This specification has been produced to meet the requirements of IGE standard IGE/TD/15 and support the installation requirements of T/PR/TMP/11 and T/PR/TMP/12.

The aim of this specification is to ensure that flow limiters installed not only conform to the HSE recommendations, but also meet the performance requirements specified herein, for reliable long-term operation within the prevailing conditions in the gas transporter medium pressure network.

## 1 Scope

**1.1** This Gas Industry Standard specifies the requirements for 32 mm flow limiters designed for polyethylene service pipes. These devices are for use with 2nd family gas, operating at inlet pressures greater than 75 mbar and not exceeding 2.0 bar, for flow rates not exceeding  $6 \text{ m}^3\text{h}^{-1}$ .

**1.2** This standard only covers flow limiters designed for installation into the bore of a polyethylene pipe conforming to GIS/PL 2-2, or for installation into the outlet spigot of a polyethylene electrofusion service tapping tee conforming to GIS/PL 2-4, or factory-fitted valves supplied as an integral part of the service tapping tee.

**1.3** This standard only covers flow limiters incorporating a bypass with an automatic reset facility.

**1.4** This standard is applicable to flow limiters suitable for operation at temperatures in the range  $-20 \text{ }^\circ\text{C}$  to  $+40 \text{ }^\circ\text{C}$ .

**1.5** This standard includes requirements for materials, design, performance testing, labelling and packaging of flow limiters.

## 2 Normative references

The following referenced documents are indispensable for the application of this document. For dated references, only the edition cited applies. For undated references, the latest edition of the referenced document (including any amendments) applies.

### Formal standards

BS EN ISO 9001, *Quality management systems — Requirements.*

BS 3156-11.0.2, *Analysis of fuel gases — Methods for non-manufactured gases — General — Quality designation for natural gas.*

### Gas Industry Standards

GIS/PL2-2, *Specification for polyethylene (polyethylene) pipes and fittings for natural gas and suitable manufactured gas — Part 2: Pipes up to 5.5 bar*

GIS/PL2-4, *Specification for polyethylene (polyethylene) pipes and fittings for natural gas and suitable manufactured gas — Part 4: Fusion fittings with integral heating element(s)*

GIS/PL2-6, *Specification for polyethylene (polyethylene) pipes and fittings for natural gas and suitable manufactured gas — Part 6: Spigot end fittings for electrofusion and/or butt fusion purposes.*

## **National Grid standards**

TMP/11, *Installation of MP metering installations for flows not exceeding 6 scmh using an approved single stage regulator with inlet pressures between 75 mbar and 2 bar.*

TMP/12, *Installation of MP metering installations for flows not exceeding 6 scmh using an approved two stage regulator with inlet pressures between 350 mbar and 2 bar.*

IGE/TD/15, *Services and metering installations for a gas flow not exceeding 6m<sup>3</sup>h<sup>-1</sup> at supply MOP exceeding 75 mbar but not exceeding 2 bar.*

## **3 Terms and definitions**

For the purposes of this standard the following terms and definitions apply.

### **3.1**

#### **flow limiter**

valve installed in a gas service pipe designed to limit or stop the flow of gas if the flow downstream of the valve exceeds a predetermined level, e.g. in the event of failure of the service pipe due to third party interference damage

### **3.2**

#### **integral valve**

flow limiter that is supplied factory-fitted into a polyethylene electrofusion service tapping tee

### **3.3**

#### **in-pipe valve**

independent flow limiter, fully enclosed within a purpose-built housing, that is to be connected to the polyethylene pipework downstream of the service tapping tee

### **3.4**

#### **bypass flow rate**

flow rate through the flow limiter after the device has been activated or tripped

## **4 Materials**

**4.1** All materials used for the components of the valve shall be suitable for conveying natural gas, of a composition within the ranges specified in BS 3156-11.0.2, or suitable manufactured gases.

**4.2** All materials used shall be capable of withstanding exposure to contaminants found within the gas transporter pipeline network including mono ethylene glycol and diethylene glycol.

**4.3** Any part, including springs, in contact with the gas or the surrounding atmosphere, shall be manufactured from corrosion-resistant materials, or shall be suitably protected. The corrosion protection for springs and other moving parts shall not be impaired by any movement.

## **5 Design**

### **5.1 General**

**5.1.1** The construction and assembly of the valve and its components shall be based on principles of safety, durability and reliability.

**5.1.2** The valve shall be designed to be installed at the junction of the service to the distribution main.

**5.1.3** In the event of the valve operating to shut off excess flow, it shall remain closed until the pressure across the device has equalized.

**5.1.4** In the shut-off condition, the valve shall permit a bypass flow rate, not exceeding 1 scmh of natural gas, in order to permit the tracing of the source of leakage and to enable automatic resetting of the device.

**5.1.5** The valve shall be capable of resetting automatically upon commissioning or repair of the service/supply.

**5.1.6** The valve shall be capable of withstanding a flow surge as detailed in **6.3**, e.g. due to instantaneous switching of high-rate appliances, over the normal operating range of the meter.

**5.1.7** The valve shall be suitable for use with polyethylene pipe conforming to GIS/PL2-2 and electrofusion fittings conforming to GIS/PL2-4.

**5.1.8** The valve body and its components shall be free from visible cracks, voids, distortion, or other defects.

**5.1.9** The valve shall be suitable for installation and operation below ground.

**5.1.10** When installed, the valve shall be positively located and retained securely within the polyethylene pipe or fitting.

**5.1.11** Where the valve is installed inside, or is an integral part of, a polyethylene service tapping tee, it shall not impair the installation, commissioning and operation of the fitting.

**5.1.12** The valve shall not be adversely affected by heat generated by electrofusion jointing operations.

**5.1.13** The design and construction of the valve shall be such that no maintenance is required once installed.

**5.1.14** The valve shall be designed to prevent dismantling or alterations in the field using standard tools.

## **5.2 Integral valves**

A service tapping tee supplied with a factory-fitted integral valve, shall be of a type that conforms to Phase II of GIS/PL2-4.

## **5.3 Maximum service pipe length for 32 mm valves**

The contractor shall specify the maximum equivalent length of 20 mm diameter MDPE pipe which can be installed downstream of a 32 mm valve, given a flow rate of  $6 \text{ m}^3\text{h}^{-1}$  and an inlet pressure of 75 mbar. This value shall be declared and stated in installation instructions supplied with the valve.

NOTE A maximum service pipe length of 25 m is regarded as typical.

## **6 Performance requirements**

### **6.1 Short term pressure test**

Any part of the valve, which may be subject to line pressure under normal operation or under fault conditions within the valve, shall be subjected to a short term pressure test according to Annex A. Following the test, the valve shall meet the requirements of **6.4**, **6.5** and **6.6**.

## **6.2 Long term strength test**

A valve shall withstand a long term strength test, in accordance with Annex B, at an internal pressure of 4 bar for a period of 2 500 h. Following the test, the valve shall meet the requirements of **6.4**, **6.5** and **6.6**.

## **6.3 Surge flow test**

When tested in accordance with Annex C, the valve shall be capable of withstanding a flow surge over its normal operating range, as given in Table C.1.

## **6.4 Trip flow rate**

When tested in accordance with Annex D, the valve shall activate within the minimum and maximum flow rate limits specified in Table D.1.

## **6.5 Bypass flow rate**

Following activation, the bypass flow rate through the valve shall not exceed 1.0 scmh of natural gas, when tested in accordance with Annex E.

## **6.6 Reset**

When tested in accordance with Annex F, the valve shall remain closed after activation and shall reset once the inlet and outlet pressures at the valve have equalized.

## **6.7 Pressure loss test**

The pressure loss across the valve shall not exceed the value given in Table G.1, at the specified flow rate, when tested in accordance with Annex G.

## **6.8 Contaminants test**

A valve, after being subjected to a contaminants test, as described in Annex H, whereby air laden with test dust and glycol is injected into the valve, shall meet the requirements of **6.7**, **6.4**, **6.5** and **6.6**, in the order shown.

An alternative contaminants test may be proposed by the contractor, with prior agreement of the gas transporter, provided that the test method can be shown to conform to a proven and recognized standard. Following the test procedure, the valve shall meet the requirements of **6.7**, **6.4** and **6.6**, in the order shown.

## **6.9 Thermal cycling test**

A valve shall be subjected to a thermal cycling test in accordance with Annex I. It shall then meet the requirements of **6.4**, **6.5** and **6.6**.

## **6.10 Impact test**

A valve, when tested in accordance with Annex J, shall withstand an impact energy of 29 J without failure.

## **7 Testing**

### **7.1 Approval testing (type testing)**

**7.1.1** Satisfactory approval testing of each size and design of valve is required before it is considered suitable for supply to the gas transporter. These type tests are detailed in Table 1 and have been devised to provide an assessment of the integrity and performance of the valve.

**Table 1 — Type test requirements**

| Schedule   | Test description               | Test method | No. of samples |
|--|--------------------------------|-------------|----------------|
| 1  | Short term pressure test       | Annex A     | 1              |
| 2  | Long term strength test        | Annex B     | 1              |
| 3  | Surge flow rate <sup>a)</sup>  | Annex C     | 3              |
| 4  | Trip flow rate <sup>a)</sup>   | Annex D     | 3              |
| 5  | Bypass flow rate <sup>a)</sup> | Annex E     | 3              |
| 6  | Reset <sup>a)</sup>            | Annex F     | 3              |
| 7  | Pressure loss                  | Annex G     | 1              |
| 8  | Contaminants test              | Annex H     | 1              |
| 9  | Thermal cycling                | Annex I     | 1              |
| 10   | Impact test                    | Annex J     | 1              |
| <sup>a)</sup> The same values may be used consecutively for these tests. |                                |             |                |

**7.1.2** Implementation of the tests in this specification are the responsibility of the contractor. Failure to meet any one of the test requirements shall be cause for rejection.

**7.1.3** The test methods outlined are reference methods. Other methods may be proposed as variants for consideration by the gas transporter.

**7.1.4** After completion of type testing, a detailed data folder containing all relevant information and test results shall be submitted to the gas transporter.

**7.1.5** No contractor can claim compliance with this standard, or include the designation of this standard on the valve or packaging marking, until approval has been granted in writing by the gas transporter.

## 7.2 Production testing

**7.2.1** Production valves shall be subjected to functional tests shown in Table 2. Additional production batch tests may be specified by the gas transporter.

**Table 2 — Production test requirements**

| Schedule   | Test description | Frequency | Test method <sup>a)</sup> |
|--|------------------|-----------|---------------------------|
| 1  | Surge flow rate  | 100 %     | Annex C                   |
| 2  | Trip flow rate   | 100 %     | Annex D                   |
| 3  | Bypass flow rate | 100 %     | Annex E                   |
| 4  | Reset            | 100 %     | Annex F                   |
| <sup>a)</sup> The contractor may propose a test method more suited to production testing for consideration by the gas transporter. |                  |           |                           |

**7.2.2** Where a formalized quality management system is a requirement of the contract, the supplier shall provide evidence of certification by an accredited independent third party certification body. Where a supplier does not hold such certification, the supplier's quality

management system shall be subject to evaluation by the gas transporter designated quality assurance personnel. The requirements of BS EN ISO 9001 shall be used for this purpose. A copy of the supplier's quality manual, relevant quality plans and other related documents shall be provided on request.

## **8 Test samples**

### **8.1 Approval testing (type testing)**

**8.1.1** Except for **6.7** (see Annex G), test specimens for the type approval tests listed in Table 1 shall be prepared as outlined below.

**8.1.2** Valves supplied as separate units (i.e. to be installed in-situ) shall be assembled into polyethylene pipe of the appropriate diameter and conforming to GIS/PL2-2. Joint assembly shall be made using an electrofusion fitting conforming to GIS/PL2-4 (e.g. a socket fitting). The free length of polyethylene pipe at either end of the fitting shall be at least five times the pipe outer diameter.

Alternatively, a purpose designed valve housing or enclosure shall be used, provided that its internal dimensions are representative of an actual installation.

**8.1.3** Integral valves shall be tested separately (i.e. prior to assembly into the tapping tee) in a suitably designed housing. The contractor shall consult the gas transporter prior to commencing tests. Otherwise, the complete assembly shall be tested.

**8.1.4** An in-pipe valve shall be assembled with a length of polyethylene pipe of at least five pipe diameters fused to the inlet and outlet connection of the valve.

### **8.2 Production testing**

Testing of production valves shall be in agreement with the gas transporter's nominated quality advisor.

## **9 Control of test conditions**

### **9.1 General**

**9.1.1** The tests and measurements shall be conducted in a standard laboratory atmosphere of  $23\text{ }^{\circ}\text{C} \pm 2\text{ }^{\circ}\text{C}$  unless otherwise specified.

**9.1.2** Unless otherwise stated, air or natural gas shall be used as the test medium to conduct the tests. All flow rates shall be corrected to standard conditions to an equivalent natural gas flow rate in scmh units.

### **9.2 Pneumatic pressure testing**

Adequate safety precautions shall be taken during any pneumatic pressure testing.

## **10 Marking**

**10.1** All valves shall be suitably and individually marked.

**10.2** Products conforming to GIS/EFV1 shall be permanently marked with the following information:

- a) valve model or type;

- b) size;
- c) pressure rating;
- d) flow direction arrow;
- e) production batch identification;
- f) the number and date of this standard, i.e. GIS/EFV1:2006 <sup>1)</sup>;
- g) the name or trademark of the manufacturer or their appointed agent;
- h) the manufacturer's contact details;
- i) where authorized, the product conformity mark of a third party certification body, e.g. BSI Kitemark.

NOTE Attention is drawn to the advantages of using third party certification of conformance to a standard.

**10.3** All marking shall remain legible under normal handling, storage and installation procedures.

### **11 Identification tag**

An identification tag shall be supplied with each valve to clearly indicate that a flow limiter is fitted to the service. The tag shall preferably be metallic, with appropriately stamped wording and of a type which can be permanently attached around the service pipe/meter box adaptor, immediately below the meter control valve.

### **12 Instructions**

The contractor shall supply leaflets, in English, detailing approved installation instructions and a diagram of the fitting. The instructions shall also meet the requirement of **5.3**.

### **13 Packaging and storage**

**13.1** The valves shall be individually packaged so that their quality is not impaired during transit or storage. The package shall contain approved assembly instructions.

**13.2** Where the valve material is susceptible to UV damage, the product shall be protected from sunlight during storage.

---

<sup>1)</sup> Marking GIS/EFV1:2006 on or in relation to a product represents a manufacturer's declaration of conformity, i.e. a claim by or on behalf of the manufacturer that the product meets the requirements of the standard. The accuracy of the claim is therefore solely the responsibility of the person making the claim. Such a declaration is not to be confused with third party certification of conformity, which may also be desirable.

## **Annex A (normative)**

### **Short term pressure test**

#### **A.1 Principle**

Test method to determine resistance of valve to short term pressure. Any part of the valve, which may be subject to line pressure under normal operation or under fault conditions within the valve, shall be exposed to the test pressure.

#### **A.2 Apparatus**

*Temperature-controlled water bath or air space*, maintained at  $20\text{ °C} \pm 2\text{ °C}$  and equipment capable of subjecting the specimen to an internal water pressure to an accuracy of  $\pm 2\%$ .

#### **A.3 Specimens**

The specimen valve shall be assembled as specified in **8.1**.

The inlet and outlet ends of the test assembly shall be closed with pressure-tight, end-load bearing end-caps or plugs which shall be provided with connections for the entry of water and the release of air.

#### **A.4 Procedure**

Fill the test assembly with water and leave to condition for a period of 1 h at the test temperature.

Pressurize the test sample internally to a pressure of 15 bar applied at a steady rate over a period of between 30 s and 120 s. Maintain the pressure for a period of 1 h.

Clean and dry the valve assembly. Then test the assembly in accordance with the requirements of:

- a) Annex D (trip flow rate);
- b) Annex E (bypass flow rate);
- c) Annex F (reset).

Failure to meet any of the above requirements is a cause for failure.

On completion of the tests remove and inspect the valve. If visible cracks or signs of damage can be seen on any part of the valve, this is cause for failure.

## **Annex B (normative)**

### **Long term strength test**

#### **B.1 Principle**

Test method to determine long term strength of valve.

#### **B.2 Apparatus**

*Temperature-controlled air space*, maintained at  $20\text{ °C} \pm 1\text{ °C}$  and equipment capable of subjecting the specimen to an internal pneumatic pressure to an accuracy of  $\pm 2\%$ . The pressurizing medium shall be air.

#### **B.3 Specimens**

The specimen valve shall be assembled as specified in **8.1**.

The inlet and outlet ends of the test assembly shall be closed with pressure-tight, end-load bearing end-caps or plugs. The inlet end shall be provided with connections for the entry and the release of air.

#### **B.4 Procedure**

Ensure appropriate safety precautions are taken to ensure protection of personnel in the event of failure of the specimen during the test.

Pressurize the test sample, through the valve inlet, to a pressure of 4 bar. Maintain this pressure within  $\pm 2\%$  for a period of 2 500 h.

Then test the valve in accordance with the requirements of:

- a) Annex D (trip flow rate);
- b) Annex E (bypass flow rate);
- c) Annex F (reset).

**Annex C (normative)**  
**Surge flow test****C.1 Principle**

Test method to determine surge flow of valve.

**C.2 Apparatus**

The apparatus shall be typically as shown in Figure C.1.

**C.3 Specimens**

The specimen valve shall be assembled as specified in **8.1**.

**C.4 Procedure**

Conduct the test at a flow rate as specified in Table C.1 and at inlet pressures of 75 mbar and 2 bar respectively.

Set the apparatus such that the gas flows from the valve via the test volume (V). Set the specified flow rate and inlet pressure by adjusting the flow outlet control valve (F) and the pressure control (A). Once set, initiate this flow instantaneously from a zero-flow condition, by rapidly opening the ball valve (E).

Ensure the valve remains in the open position.

Repeat the test procedure to obtain five determinations of surge flow. Closure, instability or oscillations in the gas flow through the valve are causes for failure.

**Table C.1 — Surge test flow rate for valves**

| <b>Nominal valve size</b><br>mm | <b>Surge flow rate</b><br>scmh natural gas |
|---------------------------------|--|
| 32                              | 6.0  |

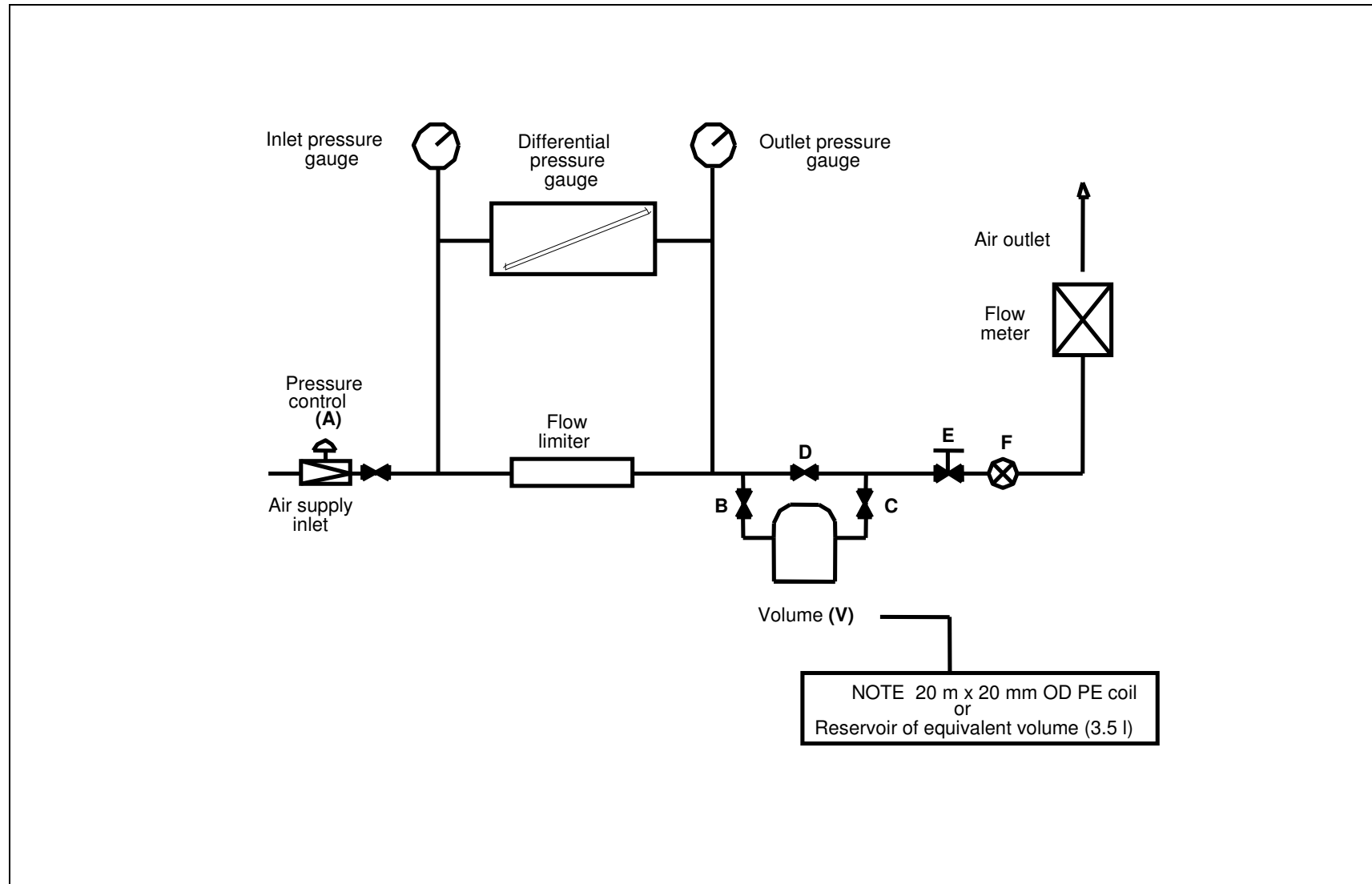

Figure C.1 — Typical apparatus for testing flow limiters

**Annex D (normative)****Trip flow rate****D.1 Principle**

Test method to determine trip flow rate of valve.

**D.2 Apparatus**

The apparatus shall be typically as shown in Figure C.1.

**D.3 Specimens**

The specimen valve shall be assembled as specified in **8.1**.

**D.4 Procedure**

Connect the valve to the apparatus in the orientation recommended by the manufacturer.

Conduct the test at inlet pressures of 75 mbar and 2 bar, respectively.

Close valves (B) and (C) to isolate the test volume (V).

Whilst maintaining the inlet pressure at the specified value, slowly open the outlet adjustment valve (F) and observe the increase in flow rate at the flow meter. Record the maximum flow rate at the instant of valve closure.

Repeat the procedure to obtain five determinations of trip flow rate and record the average reading.

The recorded flow rate shall be within the range shown in Table D.1 below.

**Table D.1 — Minimum and maximum trip flow rate for valves**

| <b>Nominal valve size</b><br>mm | <b>Minimum trip flow rate</b><br>scmh natural gas | <b>Maximum trip flow rate</b><br>scmh natural gas |
|---------------------------------|---|---|
| 32                              | 18.0  | 50.0  |

**Annex E (normative)**  
**Bypass flow rate****E.1 Principle**

Test method to determine bypass flow rate of valve.

**E.2 Apparatus**

The apparatus shall be typically as shown in Figure C.1.

**E.3 Specimens**

The specimen valve shall be assembled as specified in **8.1**.

**E.4 Procedure and requirements**

Connect the valve to the apparatus in the orientation recommended by the manufacturer.

Conduct the test at inlet pressures of 75 mbar and 2 bar, respectively

Close valves (B) and (C) to isolate the test volume (V).

Whilst maintaining the inlet pressure at the specified value, slowly open the outlet adjustment valve (F) and observe the increase in flow rate at the flow meter, until the valve trips. Note the bypass flow rate registered at the flow meter.

Repeat the procedure five times and record the average reading of bypass flow rate.

The bypass rate shall not exceed 1.0 scmh of natural gas.

## **Annex F (normative)**

### **Reset**

#### **F.1 Principle**

Test method to determine resetting of valve following closure.

#### **F.2 Apparatus**

The test apparatus shall be typically as shown in Figure C.1.

#### **F.3 Specimens**

The specimen valve shall be assembled as specified in **8.1**.

#### **F.4 Procedure and requirements**

Connect the valve to the apparatus in the orientation recommended by the manufacturer.

Conduct the test at an inlet pressure of 75 mbar and 2.0 bar, respectively.

Close valves (B) and (C) to isolate the test volume (V).

Set a flow through the valve, whilst maintaining the inlet pressure at the specified value. Open the outlet adjustment valve (F) slowly, to cause closure of the specimen valve.

Ensure the test valve remains in the closed position. Monitor the flow meter to verify that the valve has not reset.

Open valves (B and C) and close valve (D) to divert the air flow into the test volume (V).

Close valve (C) and measure the time taken for the outlet pressure gauge to reach the same value as the inlet pressure gauge.

Slowly open the outlet adjustment valve (F) and monitor the flow rate to verify that the test valve has reset.

Repeat the whole procedure to obtain five determinations of valve reset at 75 mbar and at 2.0 bar inlet pressure, respectively.

## **Annex G (normative)**

### **Pressure loss test**

#### **G.1 Principle**

The procedure described below is designed to determine the net pressure loss through a given valve type (i.e. excluding losses through the system pipework, fittings, tapping tee etc.).

#### **G.2 Apparatus**

The test apparatus shall be typically as shown in Figure C.1.

#### **G.3 Specimens**

##### **G.3.1 General**

The specimen valve shall be assembled according to the valve type, as outlined below.

##### **G.3.2 Valve installed in-situ at service tapping tee outlet**

A valve that is to be installed in-situ at the outlet spigot of a tapping tee shall be assembled as specified in **8.1.1**.

A second, identical, sample shall be assembled, but without the valve fitted.

##### **G.3.3 Integral valves**

The sample shall be assembled as shown in Figure G.1.

A second, identical, sample shall be prepared with the valve element assembly removed from the tapping tee (i.e. including any components used to retain the valve element within the tapping tee).

##### **G.3.4 In-pipe valves**

An in-pipe valve shall be assembled according to **8.1.3**.

#### **G.4 Procedure**

##### **G.4.1 General**

Connect the valve assembly to the test apparatus and follow the procedure described in **G.4.2**.

Next, for valve types outlined in **G.3.2** and **G.3.3**, connect the specimen without the valve to the rig and repeat the procedure in **G.4.2**.

For in-pipe valves, determine the system losses by removing the valve and replacing it with an equivalent length of pipe with the same diameter as the system pipework. Repeat the procedure in **G.4.2**.

##### **G.4.2 Procedure**

Partially open the outlet control valve (F) so that gas starts to flow. Adjust the pressure control (A) to regulate the pressure to 75 mbar. Record the flow rate and differential pressure.

Record several differential pressure readings for increasing gas flows, at evenly spaced intervals, by opening the flow control valve (F) and readjusting the line pressure to 75 mbar at each interval.

### G.5 Statement of results

The procedure in G.4.2 provides a number of pressure drop values and the corresponding flow rate for each. From the relationship between pressure drop and flow rate:

$$\Delta P = FQ^2$$

where

$\Delta P$  is the pressure drop in millibar (mbar);

$F$  is a factor;

$Q$  is the flow rate, in cubic metres per hour (m<sup>3</sup>/h).

The factor  $F$  shall be calculated for each set of readings and the average value determined.

Using the average value, the pressure drop shall be determined for a gas flow rate ( $Q$ ) appropriate for the size of the service fitting as shown in Table G.1. The system losses shall be similarly determined and subtracted from the overall pressure drop value to determine the net pressure loss through the valve.

The pressure loss across the valve shall not exceed the value specified in Table G.1.

**Table G.1 — Maximum allowable pressure drop across valves**

| Nominal valve size<br>mm | Flow rate of natural gas<br>scmh | Maximum pressure drop across valve<br>mbar |
|--------------------------|----------------------------------|--|
| 32                       | 4.3                              | 8.0  |

NOTE If air or nitrogen is used for this test, correct the flow rates using the following relationship:

$$Q_{\text{nat}} = Q_{\text{med}} \sqrt{\rho_{\text{med}} / \rho_{\text{nat}}}$$

where

$Q_{\text{nat}}$  is the flow rate using natural gas in cubic metres per hour (m<sup>3</sup>/h);

$Q_{\text{med}}$  is the flow rate using other gas in cubic metres per hour (m<sup>3</sup>/h);

$\rho_{\text{med}}$  is the density of the other gas;

$\rho_{\text{nat}}$  is the density of natural gas = 0.71 kg/m<sup>3</sup>.

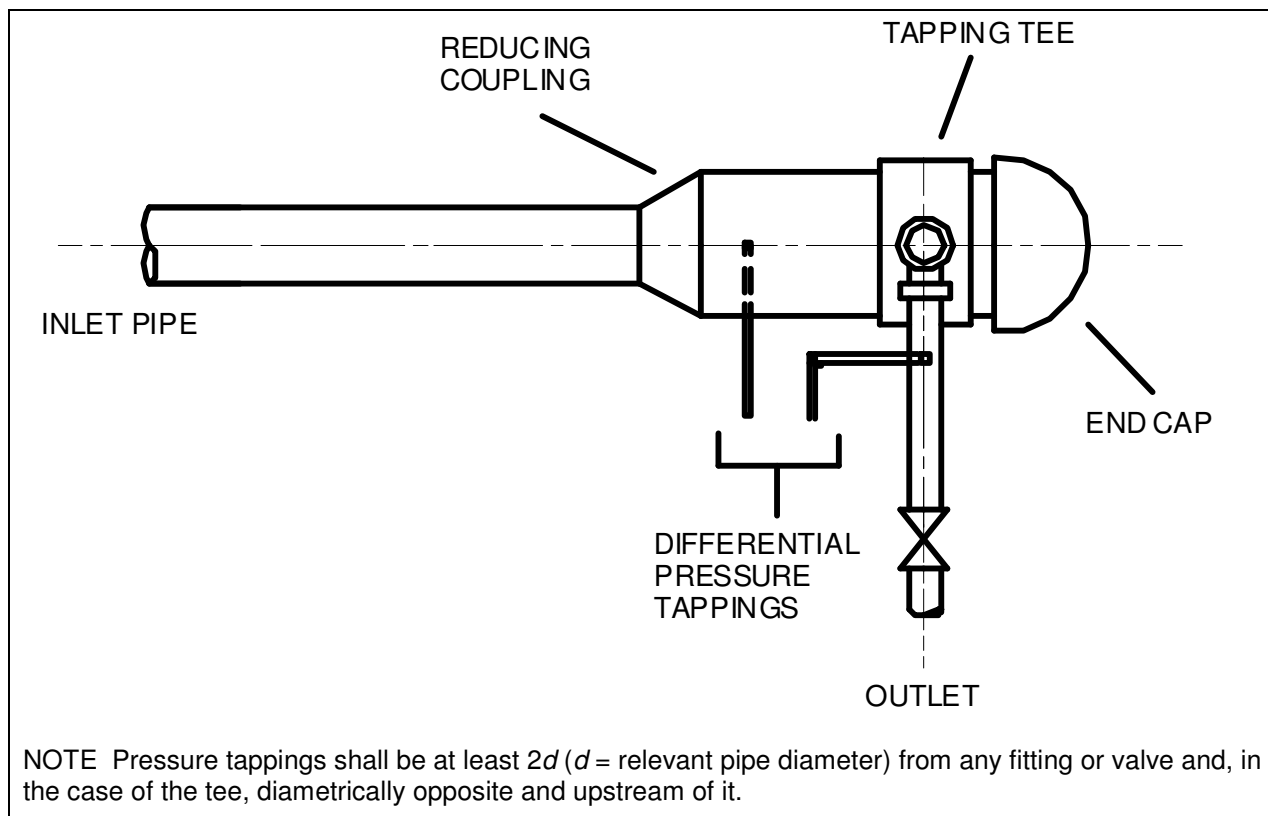

**Figure G.1 — Typical assembly method for integral valve specimen for pressure testing**

## **Annex H (normative)**

### **Contaminants test**

#### **H.1 Principle**

Test method to determine resistance of valve to blockage by in-pipe contaminants.

#### **H.2 Apparatus**

**H.2.1** *Means of injecting a specified amount of dust and glycol*, into the gas upstream of the valve, at a specified gas velocity. The glycol injection system shall be capable of injecting the glycol into the gas stream. Measures shall be taken to prevent egress of dust or glycol into the atmosphere from the pipe outlet, e.g. by means of suitable filtration equipment.

**H.2.2** *Test dust*, consisting of iron oxide ( $\text{Fe}_3\text{O}_4$ ) with a particle size range of 300  $\mu\text{m}$  to 600  $\mu\text{m}$ .

**H.2.3** *Contaminants test rig*, independent stand-alone unit. Following contaminants injection, the test valve shall subsequently be transferred to a separate rig to carry out the performance requirement tests. It shall be ensured that any disturbance of the valve during transfer is avoided.

#### **H.3 Specimens**

The specimen valve shall be assembled as specified in **8.1**.

#### **H.4 Procedure**

Connect the valve to the apparatus in the orientation recommended by the manufacturer. Set the pressure regulator to maintain an inlet pressure of 2 bar.

Set the flow to give a gas velocity of 10 m/s in the pipe. Inject 10  $\text{cm}^3$  of glycol at a constant rate over a period of 10 min into the pipe. On completion of the glycol injection, immediately inject 10 g of dust into the pipe at a constant rate, over a period of 10 min.

Then test the valve in accordance with the following requirements, in order shown below:

- a) Annex G (pressure loss);
- b) Annex D (trip flow rate);
- c) Annex E (bypass flow rate);
- d) Annex F (reset).

## **Annex I (normative)**

### **Thermal cycling test**

#### **I.1 Principle**

Test method to determine temperature resistance of valve. A cycle is defined as starting with the valve in the open position, increasing the flow to close the valve and then resetting the valve to the open position.

#### **I.2 Apparatus**

The apparatus shall be typically as shown in Figure C.1, capable of cycling the valve at the specified minimum and maximum operating temperatures.

#### **I.3 Specimens**

The specimen valve shall be assembled as specified in **8.1**.

#### **I.4 Procedure**

Maintain the valve at  $60\text{ °C} \pm 2\text{ °C}$  for a period of 24 hours. Cycle the valve 10 times, as defined in **I.1**. Allow specimen to cool to room temperature.

Decrease the temperature to  $-20\text{ °C} \pm 2\text{ °C}$  and maintain for a period of 24 h. Cycle the valve 10 times, as defined in **I.1**. Allow sample to recover to room temperature.

Then test the valve in accordance with the requirements of:

- a) Annex D (trip flow rate);
- b) Annex E (bypass flow rate);
- c) Annex F (reset).

## **Annex J (normative)**

### **Impact test**

#### **J.1 Principle**

Test method to determine impact resistance of valve.

#### **J.2 Apparatus**

The test apparatus shall be typically as shown in Figure J.1a and shall consist of a steel striker with a mass of  $3 \text{ kg} \pm 0.1 \text{ kg}$  and a flat striking face of 12 mm diameter made of hardened steel. It shall be free to slide within a smooth bore tube with a clearance not exceeding 0.5 mm.

#### **J.3 Specimens**

##### **J.3.1 General**

The specimen valve shall be assembled according to the valve type, as outlined below.

##### **J.3.2 Valves installed in tapping tees**

Use the following method for valves that are supplied factory-fitted into service tapping tees, or are installed at the outlet spigot of the tapping tee:

Fuse a polyethylene service tapping tee conforming to GIS/PL2-4 onto a polyethylene pipe of a length of at least three pipe diameters. Install the valve according to the manufacturer's instructions and connect to the outlet of the tee using an electrofusion socket fitting conforming to GIS/PL2-4. Connect a short length of polyethylene pipe, of a length of at least three pipe diameters, to the outlet of the socket, prior to electrofusion.

##### **J.3.3 In-pipe valves**

Assemble a valve that is normally installed in the polyethylene pipe, downstream of the tapping tee, as outlined below:

Assemble the valve according to the manufacturer's instructions, with a length of polyethylene pipe of at least five pipe diameters fused to the inlet and outlet connection on the valve.

#### **J.4 Procedure**

Carry out the test at least 24 h after electrofusion.

Condition the specimen at  $-5 \text{ °C} \pm 2 \text{ °C}$  for at least 1 h prior to testing.

Conduct testing at  $23 \text{ °C} \pm 2 \text{ °C}$  and complete within 5 min of removing the assembly from the conditioning chamber.

Clamp the assembly rigidly so as to prevent movement of the specimen during impact (see Figures J.1b and J.1c). Secure the guide tube rigidly, with the end resting directly above, or as near as practical, to the valve in its installed position.

Arrange the striker to fall freely from a height of 1 m (equivalent to an impact energy of 29 J). Make a single impact.

Then test the valve in accordance with the requirements of:

- a) Annex D (trip flow rate);
- b) Annex E (bypass flow rate);
- c) Annex F (reset).

Carefully remove the valve from the assembly and examine. Any visual signs of damage, breakage or cracking are cause for failure.

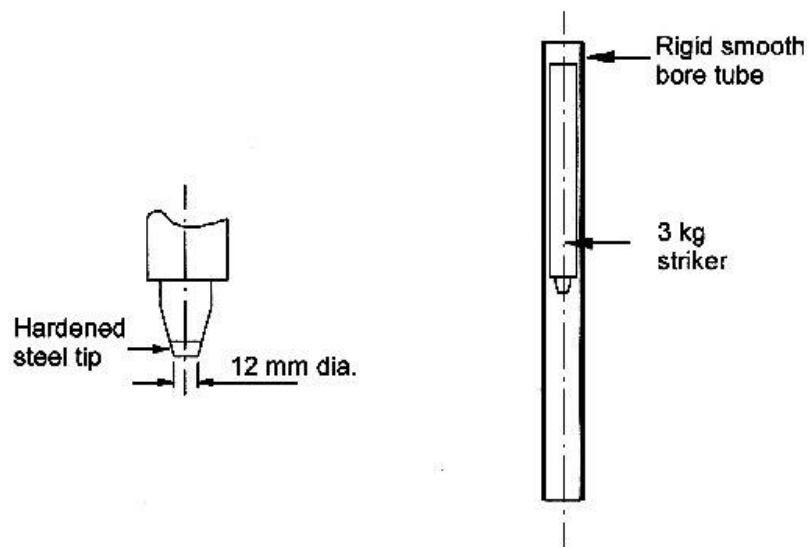

a) Typical impact test apparatus (not to scale)

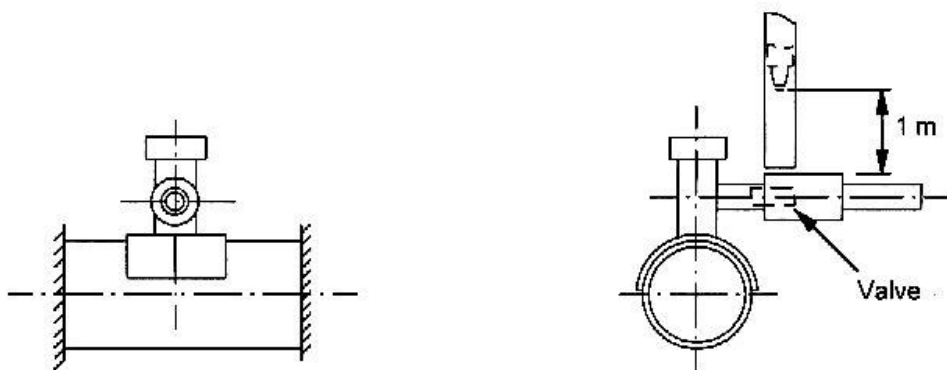

b) Typical layout of impact test apparatus for valves installed in service tapping tees

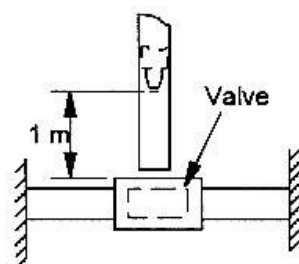

c) Typical layout of impact test apparatus for in-pipe valves

Figure J.1 — Typical apparatus for testing flow limiters