

Transmission Access Review

Pre-consultation [to be published]

Charging Arrangements associated with CAP171

nationalgrid

The power of action.™

Agenda

Introduction

- ◆ CAP171: Rationale and description

Charging Principles

Dimensions of modelling issues

Other charging issues

Illustrative example

Introduction: Rationale for CAP171

Original transmission access review amendments based on providing Users with choice between short-term and long-term access

What are the practical problems?

- ◆ Impossible to 'bank' new projects based on exposure to short-term costs
- ◆ Users (particularly wind) don't know:
 - What level of long-term rights they need
 - How much they should bid

How do we solve them?

- ◆ SO makes decisions on Users behalf based on information revealed via a pricing process
- ◆ SO calculates price based on the most efficient mix possible of long-term and short-term rights

Introduction: CAP171 High level description

Transmission access is allocated in an annual multi-round capacity pricing mechanism

Users provide additional information about their intended use of the transmission network, including capacity (MW), duration (years), load duration and bid price collar

National Grid forecast time average short-run marginal prices (location and running regime dependent)

Users have the opportunity to revise their position

Process closes when deadline is reached or stability criterion is satisfied

Charging Principles 1

NG propose changes to the charging arrangements for generation only

Capacity pricing mechanism will be used to set the locational element of charges based on time-average SRMCs

This will replace the Investment Cost Related Pricing Transport and Tariff model and any other arrangements which may be in place to calculate a locational element of BSUoS charges

At efficient transmission investment level, time-average SRMC = LRMC

Under-investment: time-average SRMC > LRMC

- ◆ Connection of generation ahead of wider reinforcements

Charging Principles 2

Over-investment: time-average SRMC < LRMC

- ◆ Historic investments
- ◆ “Lumpy” investments

Should time-average SRMC be collared at:

- ◆ TNUoS (capacity based price); or
- ◆ Time-average SRMC calculated based on theoretical efficient transmission investment level

Introduction: Short-run marginal costs

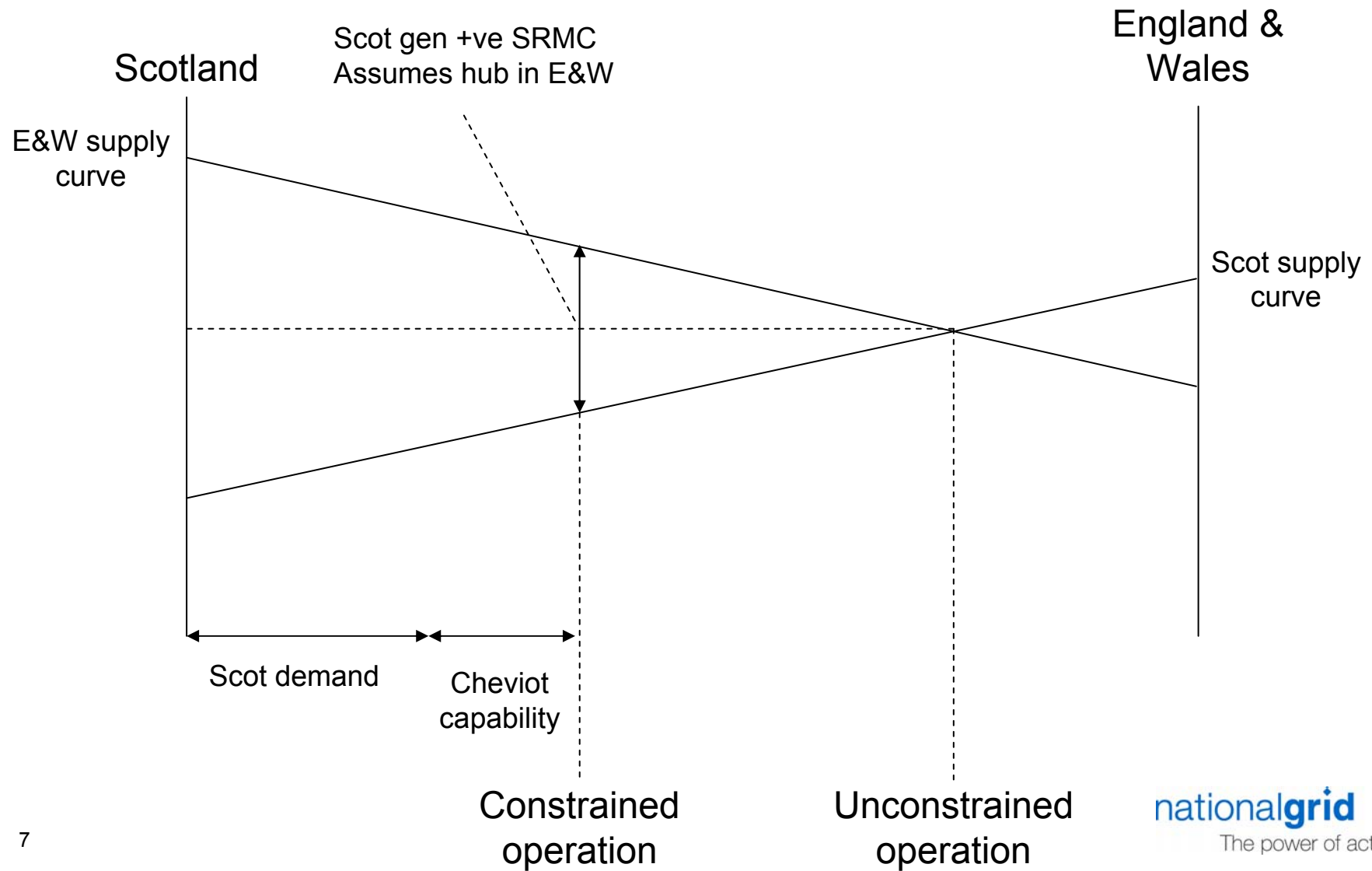

Summary of capacity pricing mechanism

- Step 1** Use the load duration data submitted by users to calculate generation availability for a number of anticipated demand scenarios for each relevant year;
- Step 2** For each scenario, produce an unconstrained generation schedule based on setting generation equal to demand whilst seeking to minimise cost according to a ranking order;
- Step 3** For each unconstrained generation schedule, produce a constrained schedule by taking bids and offers to resolve any system overload issues, calculated by a loadflow model, whilst seeking to minimise system balancing cost. The shadow costs from this optimisation are demand locational short-run marginal costs;
- Step 4** Use the shadow costs obtained from step 3 above to calculate the associated (equal and opposite) generation locational short-run marginal costs. Multiply the forecast generation output by these locational short-run marginal costs and average over each of the demand scenarios used to describe the relevant year;
- Step 5** Calculate the appropriate residual tariff to ensure TNUoS and BSUoS revenue recovery.

Dimensions of system modelling issues

Multiple years

- ◆ Need to consider test to justify incremental investment

Granularity of time modelling within year

- ◆ No of seasons / demand levels

Nature of loadflow model

- ◆ Boundary / dc loadflow / ac loadflow

Size of network and network modelling

- ◆ Transmission outages and reinforcements

Granularity of generation and merit order modelling

- ◆ Simplistic ranking order / derived from bid data

Style of modelling of generation availability

- ◆ Deterministic / probabilistic

Other charging issues

Implications for overrun charge

- ◆ Calculating overrun volume above specified load duration
- ◆ Based on SRMC

Volume corrections

- ◆ Correcting for specified load duration

Setting the hub

- ◆ Achieving revenue recovery
- ◆ Consistency with overrun charge

Residual charge

- ◆ Single residual / Residual for TNUoS and BSUoS

Illustrative example 1

Modelling of generation availability	Probabilistic
Granularity of time modelling within year	Winter high (17 blocks); winter low (13 blocks); summer high (13 blocks); summer low (7 blocks)
Ranking order modelling	Based on bid price collar
Nature of loadflow model	Boundary
Size of network and network modelling	Tree network 15 boundaries; 67 power stations; Intact network assumed
Multiple years	Single year only

Illustrative example 2

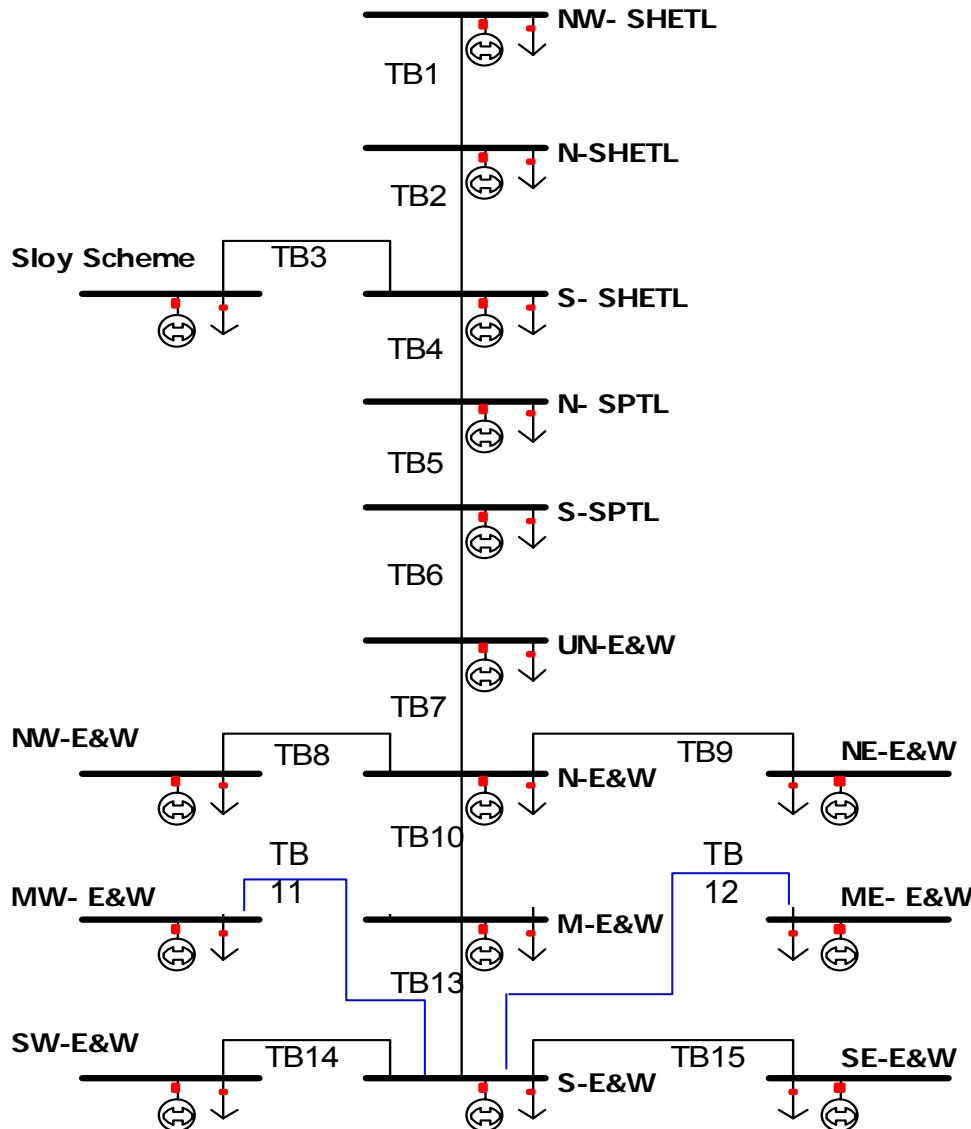

Transmission system

- ◆ 16 node 'tree' model used to represent GB transmission network
 - Based on SQSS review work on DTIM
 - Modelled 2008/9 network and 2013/14 network

Other

- ◆ Typical bid and offer prices
- ◆ Typical capacity schedules

Note:

Model based on intact network only

Model has not been validated against more detailed constraint forecast work

Illustrative example - Some results

	North Scot Wind	North Scot Pump Storage	North Scot Base Gas	South Scot Marg Coal	Scot Nuclear
2008/09 generation & transmission	£17.05/kW	£30.89/kW	£42.82/kW	£39.36/kW	£36.92/kW
2013/14 generation					
2008/09 transmission	£162.48/kW	£277.46/kW	£299.55/kW	£274.55/kW	£257.47/kW
2012/13 transmission	£90.37/kW	£151.74/kW	£226.14/kW	£206.99/kW	£194.08/kW
2014/15 transmission	£20.02/kW	£36.46/kW	£49.93/kW	£45.47/kW	£42.61/kW